

Installation, Use and Maintenance Manual

GAHP A

Air-Water gas absorption heat pump

powered by gas and renewable energies



Revision: D

Code: D-LBR724

This Installation, use and maintenance manual has been drawn up and printed by Lochinvar Ltd; whole or partial reproduction of this Installation, use and maintenance manual is prohibited.

The original is filed at Lochinvar Ltd.

Any use of this Installation, use and maintenance manual other than for personal consultation must be previously authorised by Lochinvar Ltd.

The rights of those who have legitimately filed the registered trademarks contained within this publication are not affected.

With the aim of continuously improving the quality of its products, Lochinvar Ltd reserves the right to modify the data and contents of this Installation, use and maintenance manual without prior notice.

INDEX OF CONTENTS

I Introduction	p. 4	3.8	System filling.....	p. 22
I.1 Recipients.....	p. 4	3.9	Fuel gas supply.....	p. 22
I.2 Control device.....	p. 4	3.10	Combustion products exhaust.....	p. 23
II Symbols and definitions	p. 4	3.11	Flue gas condensate discharge.....	p. 23
II.1 Key to symbols.....	p. 4	3.12	Defrosting water drainage.....	p. 24
II.2 Terms and definitions.....	p. 4	4 Electrical installer		p. 24
III Warnings	p. 4	4.1 Warnings.....		p. 24
III.1 General and safety warnings.....	p. 4	4.2 Electrical systems.....		p. 24
III.2 Conformity.....	p. 6	4.3 Electrical power supply.....		p. 25
III.3 Exclusions of liability and warranty.....	p. 6	4.4 Set-up and control.....		p. 26
1 Features and technical data	p. 7	4.5 Water circulation pump.....		p. 27
1.1 Features.....	p. 7	5 First start-up		p. 29
1.2 Dimensions.....	p. 7	5.1 Preliminary checks.....		p. 30
1.3 Components.....	p. 9	5.2 Electronic adjustment on the machine – Menus and parameters of the S61 board.....		p. 30
1.4 Electrical wiring diagram.....	p. 12	5.3 Modifying settings.....		p. 31
1.5 Electronic boards.....	p. 13	6 Normal operation		p. 31
1.6 Operation mode.....	p. 16	6.1 Warnings.....		p. 31
1.7 Controls.....	p. 16	6.2 Switch on and off.....		p. 32
1.8 Technical characteristics.....	p. 16	6.3 Modifying settings.....		p. 32
2 Transport and positioning	p. 18	6.4 Efficiency.....		p. 32
2.1 Warnings.....	p. 18	7 Maintenance		p. 32
2.2 Handling.....	p. 18	7.1 Warnings.....		p. 32
2.3 Appliance positioning.....	p. 18	7.2 Pre-emptive maintenance.....		p. 32
2.4 Minimum clearance distances.....	p. 19	7.3 Scheduled routine maintenance.....		p. 33
2.5 Mounting base.....	p. 19	7.4 Messages on the display.....		p. 33
3 Heating engineer	p. 19	7.5 Restarting a locked-down unit.....		p. 33
3.1 Warnings.....	p. 19	7.6 Periods of inactivity.....		p. 34
3.2 Hydraulic system.....	p. 20	8 Diagnostics		p. 34
3.3 Hydraulic connections.....	p. 20	8.1 Operative codes.....		p. 34
3.4 Water circulation pump.....	p. 20	Appendices		p. 37
3.5 Antifreeze function.....	p. 20	Product fiche.....		p. 37
3.6 Antifreeze liquid.....	p. 21			
3.7 System water quality.....	p. 21			

I INTRODUCTION



Manual

This Manual is an integral part of the GAHP A unit and must be handed to the end user together with the appliance.

I.1 RECIPIENTS

This Manual is intended for:

- ▶ End user, for appropriate and safe use of the appliance.
- ▶ Qualified installer, for correct appliance installation.
- ▶ Planner, for specific information on the appliance.

I.2 CONTROL DEVICE

In order to be able to work, the GAHP A unit needs a control device (DDC, CCP/CCI or external requests), which must be connected by the installer.

II SYMBOLS AND DEFINITIONS

II.1 KEY TO SYMBOLS



DANGER



WARNING



NOTE



PROCEDURE



REFERENCE (to other document)

II.2 TERMS AND DEFINITIONS

GAHP Appliance/Unit = equivalent terms, both used to designate the gas powered absorption heat pump GAHP (Gas Absorption Heat Pump).

TAC = Technical Assistance Centre authorised by Lochinvar.

External request = generic control device (e.g. thermostat, clock or any other system) equipped with a voltage-free NO contact and used as control to start/stop the GAHP unit.

CCI Controller (Comfort Controller Interface) = optional Lochinvar control device which lets you manage up to three modulating heat only GAHP units (A, WS, GS).

CCP Controller (Comfort Control Panel) = Lochinvar control device which lets you manage in modulation mode up to three GAHP units and all system components (probes, diverter/mixing valves, circulating pumps), including any integration boiler.

DDC Control (Direct Digital Controller) = optional Lochinvar device to control one or more Lochinvar appliances (GAHP heat pumps, GA chillers and AY boilers) in ON/OFF mode.

RB100/RB200 Devices (Robur Box) = optional interface devices complementary to DDC, which may be used to broaden its functions (heating/cooling/DHW production service demands, and control of system components such as third party generators, adjustment valves, circulators, probes).

Heat generator = equipment (e.g. boiler, heat pump, etc..) producing heating and/or DHW.

GUE (Gas Utilization Efficiency) = efficiency index of gas heat pumps, equal to the ratio between the thermal energy produced and the energy of the fuel used (relative to LCV, lower calorific value).

First start-up = appliance commissioning operation which may only and exclusively be carried out by a TAC.

S61/Mod10/W10 Boards = electronic boards on the GAHP unit, to control all functions and to provide interface with other devices and with the user.

III WARNINGS

III.1 GENERAL AND SAFETY WARNINGS



Installer's qualifications

Installation must exclusively be performed by a qualified firm and by qualified personnel, with specific knowledge on heating, cooling, electrical systems and gas appliances, in compliance with the laws in force in the Country of installation.



Declaration of conformity

Upon completing installation, the installing firm shall issue to the owner/client the appliance's workmanlike conformity declaration, according to national/local regulations in force and the manufacturer's instructions/provisions.



Misuse

The appliance must only be used for the purposes for which it has been designed. Any other use is deemed hazardous. Incorrect use may affect operation, duration and safety of the appliance. Adhere to the manufacturer's instructions.



Hazardous situations

- Do not start the appliance in hazardous conditions, such as: gas smell, problems with the plumbing/electrical/gas system, parts of the appliance under water or damaged, malfunctioning, disabling or bypassing control and safety devices.
- In case of danger, request intervention by qualified personnel.
- In case of danger, switch off the electrical power and gas supplies only if this can be done in total safety.

- Do not entrust children, persons with physical, sensory or mental disabilities or persons with poor knowledge and experience with use of the appliance.



Gas component tightness

- Before performing any operation on gas ducting components, close the gas valve.
- Upon completing any procedure, perform the tightness test according to regulations in force.



Gas smell

If you smell gas:

- Do not use electrical devices such as telephones, multimeters or other equipment that may cause sparks next to the appliance.
- Shut off the gas supply by turning the valve off.
- Disconnect electrical power supply by means of the external isolation switch in the power supply electrical panel.
- Use a telephone away from the appliance to ask for intervention from qualified personnel.



Poisoning

- Ensure the flue gas ducts are tightness and compliant with the regulations in force.
- Upon completing any procedure, ensure components are tightness.



Moving parts

The appliance contains moving parts.

- Do not remove guards during operation, and in any case prior to disconnecting the power supply.



Burn hazard

The appliance contains very hot parts.

- Do not open the appliance and do not touch internal components before the appliance has cooled down.
- Do not touch the flue gas exhaust before it has cooled down.



Pressure vessels

The appliance has a sealed circuit classified as pressure vessel, the tightness of which is tested by the manufacturer.

- Do not carry out any intervention on the sealed circuit or on the appliance's valves.



Water-ammonia solution

The GAHP/GA unit uses the ammonia-water absorption cycle. The water-ammonia solution is contained in the sealed circuit. The solution is harmful for health if it is ingested, inhaled or comes in contact with the skin.

- In the event of coolant leak keep away and disconnect the power and gas supply (only if it is possible to do so with no danger).
- Ask for TAC intervention.



Electrocution hazard

- Disconnect the electrical power supply before any operation on appliance components.

- For electrical connections exclusively use compliant components and according to the specifications provided by the manufacturer.

- Ensure the appliance cannot be accidentally switched back on.



Earthing

Electrical safety depends on effective earthing system, correctly connected to the appliance and installed according to the regulations in force.



Distance from combustible or flammable materials

- Do not deposit flammable materials (paper, diluents, paints, etc.) near the appliance.



Limescale and corrosion

Depending on the chemical/physical properties of the system water, limescale or corrosion may damage the appliance (Paragraph 3.7 p. 21).

- Check system sealing.
- Avoid frequent top-ups.



Chloride concentration

The concentration of chlorides or free chlorine in the system water must not exceed the values in Table 3.2 p. 21.



Aggressive substances in air

Halogenated hydrocarbons containing chlorine and fluorine compounds cause corrosion. The air of the installation site must be free from aggressive substances.



Acid flue gas condensate

- Discharge the acid condensate of combustion flue gas, as indicated in Paragraph 3.11 p. 23, in compliance with current exhaust regulations.



Switching the appliance off

Disconnecting the power supply while the appliance is running may cause permanent damage to internal components.

- Except in the case of danger, do not disconnect the power supply to switch off the appliance, but always and exclusively act through the provided control device (DDC, CCP/CCI or external request).



In the event of failure

Operations on internal components and repairs may exclusively be carried out by a TAC, using only original parts.

- In the event of failure of the appliance and/or breakage of any component, do not attempt to repair and/or restore and immediately contact the TAC.



Routine maintenance

Proper maintenance assures the efficiency and good operation of the appliance over time.

- Maintenance must be performed according to the

manufacturer's instructions (see Chapter 7 p. 32) and in compliance with current regulations.

- Appliance maintenance and repairs may only be entrusted to firms legally authorised to work on gas appliances and systems.
- Enter into a maintenance contract with an authorised specialised firm for routine maintenance and for servicing in case of need.
- Use only original parts.



Decommissioning and disposal

If the appliance is to be disposed of, contact the manufacturer for its disposal.



Keep the Manual

This Installation, use and maintenance manual must always accompany the appliance and must be handed to the new owner or installer in the event of sale or removal.



In particular, the warranty on the appliance may be rendered void by the following conditions:

- Incorrect installation.
- Misuse.
- Failure to comply with the manufacturer's indications on installation, use and maintenance.
- Alteration or modification of the product or any part thereof.
- Extreme operational conditions or however outside of the operational ranges set forth by the manufacturer.
- Damages caused by external agents such as salts, chlorine, sulphur or other chemical substances contained in the installation water or present in the air of the installation site.
- Abnormal actions transmitted to the appliance by the plant or installation (mechanical stresses, pressure, vibrations, thermal expansion, electrical surges...).
- Accidental damages or due to force majeure.

III.2 CONFORMITY

EU Directives and standards

The absorption heat pumps of the GAHP series are certified as conforming to standard EN 12309 and comply with the essential requirements of the following Directives:

- ▶ 2016/426/EU "Gas Appliances Regulation" as amended and added.
- ▶ 2014/30/EC "Electromagnetic Compatibility Directive" as amended and added.
- ▶ 2014/35/EC "Low Voltage Directive" as amended and added.
- ▶ 2006/42/EC "Machine Directive" as amended and added.
- ▶ 2014/68/EU "Pressure Equipment Directive" as amended and added.

Furthermore, they comply with the requirements of the following standards:

- ▶ EN 677 Specific requirements for condensing boilers with nominal heat input up to 70 kW.
- ▶ EN 378 Refrigerating systems and heat pumps.

Other applicable provisions and standards

The design, installation, operation and maintenance of the systems shall be carried out in compliance with current applicable regulations, depending on the Country and location, and in accordance with the manufacturer's instructions. In particular, regulations regarding the following shall be complied with:

- ▶ Gas systems and equipment.
- ▶ Electrical systems and equipment.
- ▶ Heating and air conditioning systems, and heat pumps.
- ▶ Environmental protection and combustion products exhaust.
- ▶ Fire safety and prevention.
- ▶ Any other applicable law, standard and regulation.

III.3 EXCLUSIONS OF LIABILITY AND WARRANTY



Any contractual or extra-contractual liability of the manufacturer for any damage caused by incorrect installation and/or improper use and/or failure to comply with regulations and with the manufacturer's directions/instructions shall be disclaimed.

1 FEATURES AND TECHNICAL DATA

1.1 FEATURES

Operation

Based on the thermodynamic water-ammonia absorption cycle (H_2O-NH_3), the appliance produces hot water using outdoor air as a renewable energy source (cold source) and natural gas (or LPG) as primary energy.

The thermodynamic cycle takes place within a hermetically sealed circuit, in welded construction, perfectly tight, factory-tested, which does not require any maintenance or coolant top-ups.

Mechanical and thermo-hydraulic components

- ▶ Steel sealed circuit, externally treated with epoxy paint.
- ▶ Sealed combustion chamber (type C) suitable for outdoor installations.
- ▶ Metal mesh radiant burner, equipped with ignition electrodes and flame detection, managed by an electronic flame control box.
- ▶ Titanium stainless steel shell-and-tube water heat exchanger, externally insulated.
- ▶ Stainless steel, shell-and-tube recovery exchanger of flue gas latent heat.
- ▶ Air exchanger with finned coil, with steel pipe and aluminium fins.
- ▶ Automatic microprocessor-controlled finned coil defrosting

valve.

- ▶ Standard or S1 silenced fan (reduction of electrical consumption and reduction of sound emission).

Control and safety devices

- ▶ S61 electronic board with microprocessor, LCD display and knob.
- ▶ Mod10 additional electronic board (integrated in S61).
- ▶ Auxiliary W10 electronic board.
- ▶ Water flowmeter.
- ▶ Generator limit thermostat, with manual reset.
- ▶ Flue gas thermostat, with manual reset.
- ▶ Generator fins temperature probe.
- ▶ Sealed circuit safety relief valve.
- ▶ Bypass valve, between high and low-pressure circuits.
- ▶ Ionization flame control box.
- ▶ Double shutter electric gas valve.
- ▶ Antifreeze functions for hydraulic circuit.
- ▶ Condensate discharge sensor.

Standard or silenced fan

According to the type of fan the GAHP A unit is available in two versions:

- ▶ Standard fan, for applications that do not require a special degree of noiselessness.
- ▶ Silenced fan, for applications that require a high degree of noiselessness.

1.2 DIMENSIONS

Figure 1.1 Service plate - Hydraulic/gas unions detail

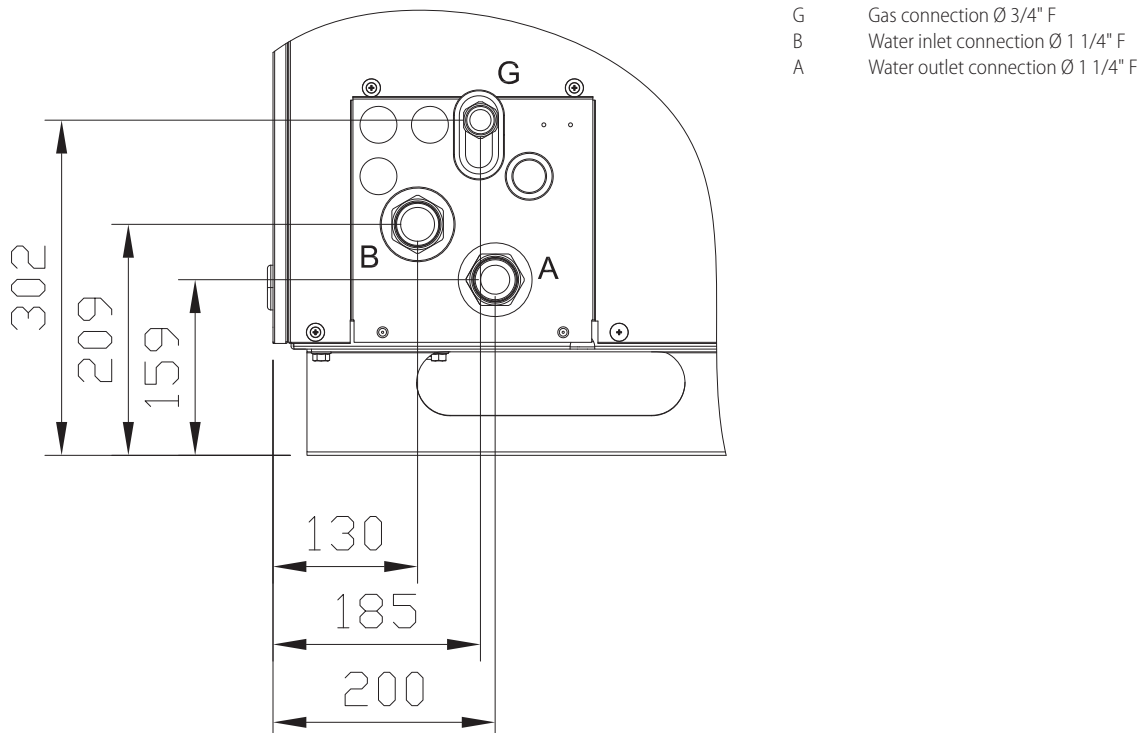

Figure 1.2 Size (Standard ventilation)

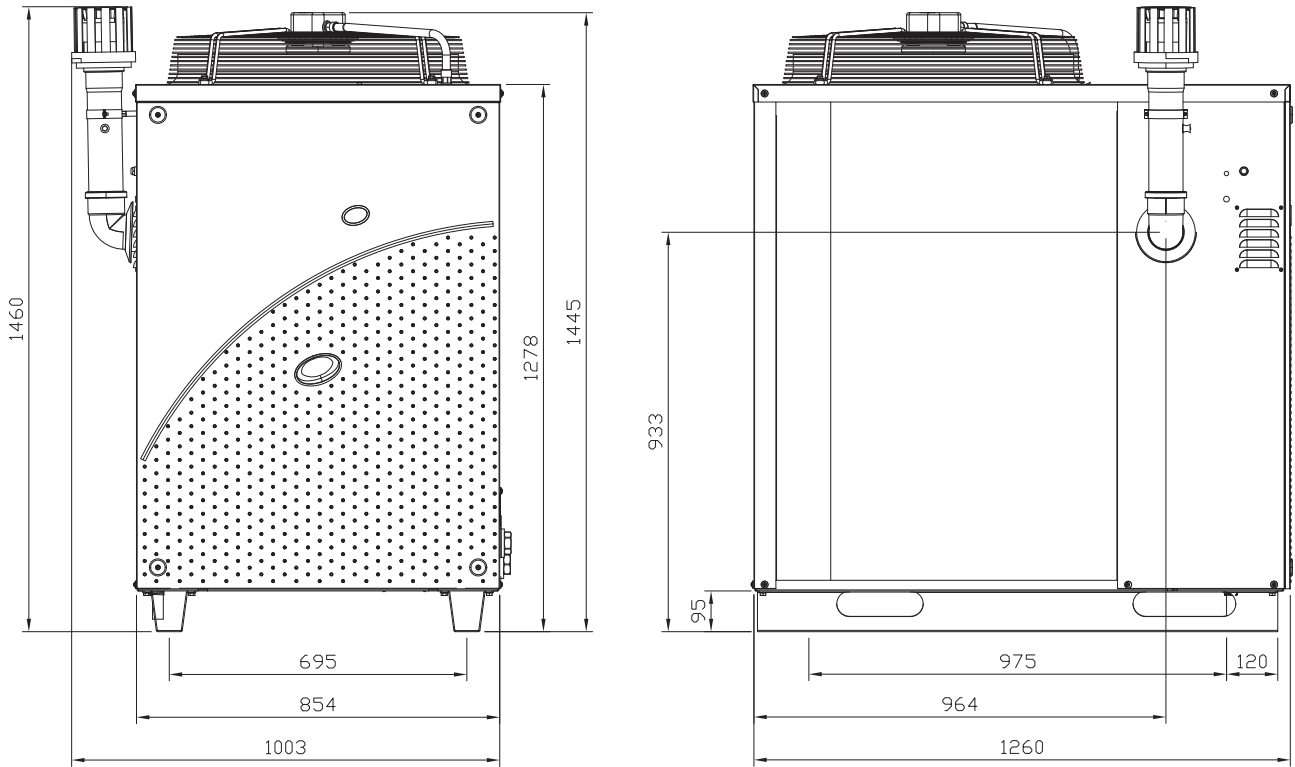
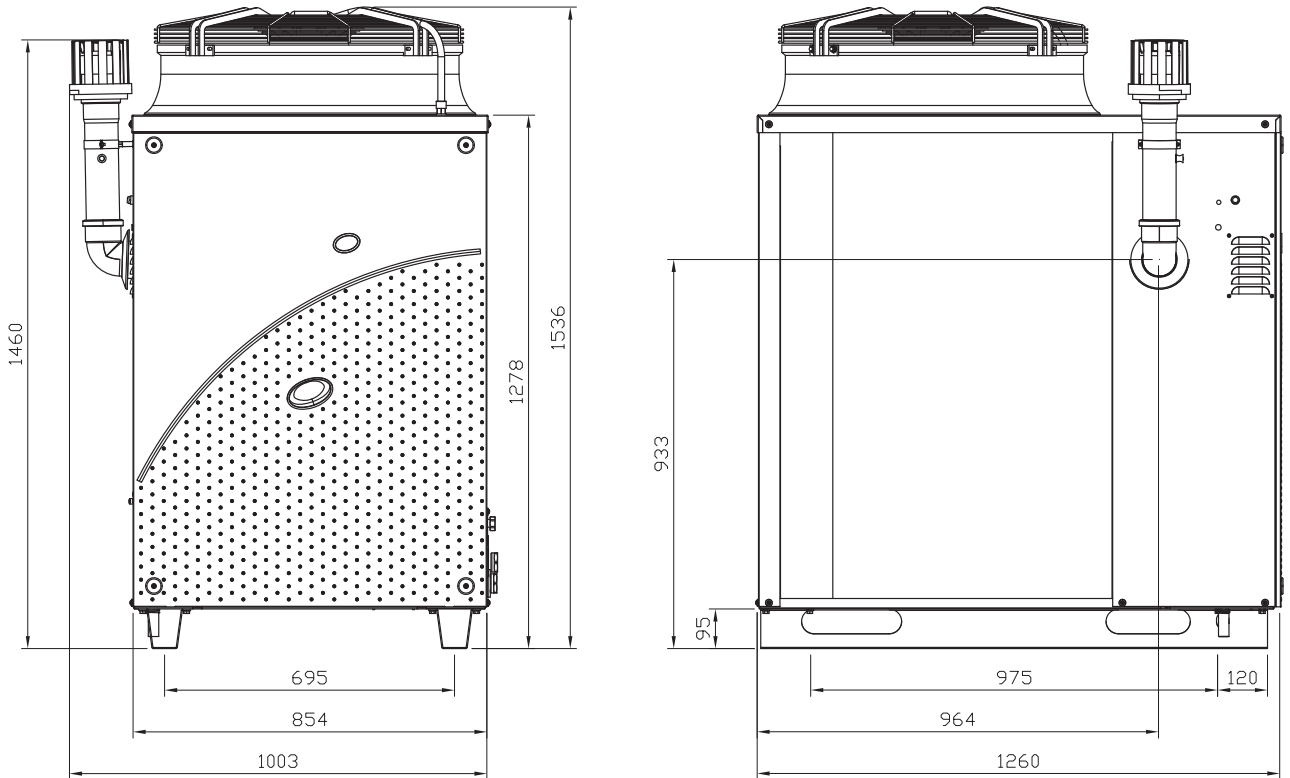
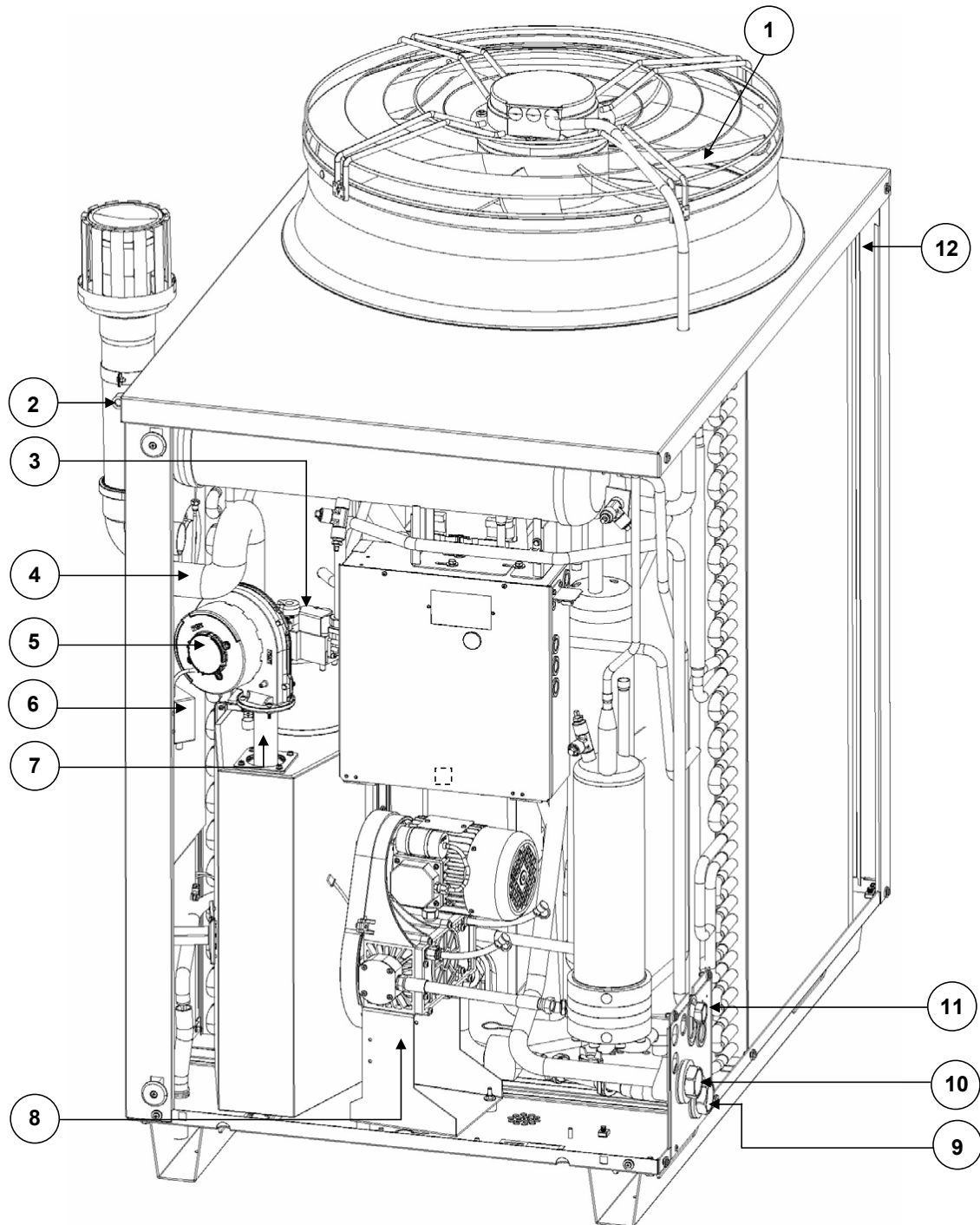

Figure 1.3 Dimensions (low consumption silenced fan)



1.3 COMPONENTS

Figure 1.4 Internal components - front view



- 1 Fan (S1 version)
- 2 Tapping point for flue analysis
- 3 Gas valve
- 4 Combustion air hose
- 5 Combustion blower
- 6 Ignition transformer
- 7 Tmix air-gas mixture temperature probe
- 8 Oil pump
- 9 Water inlet connection \varnothing 1 1/4" F
- 10 Water outlet connection \varnothing 1 1/4" F
- 11 Gas connection \varnothing 3/4" F
- 12 TA outdoor temperature probe

Figure 1.5 Internal components - left side view

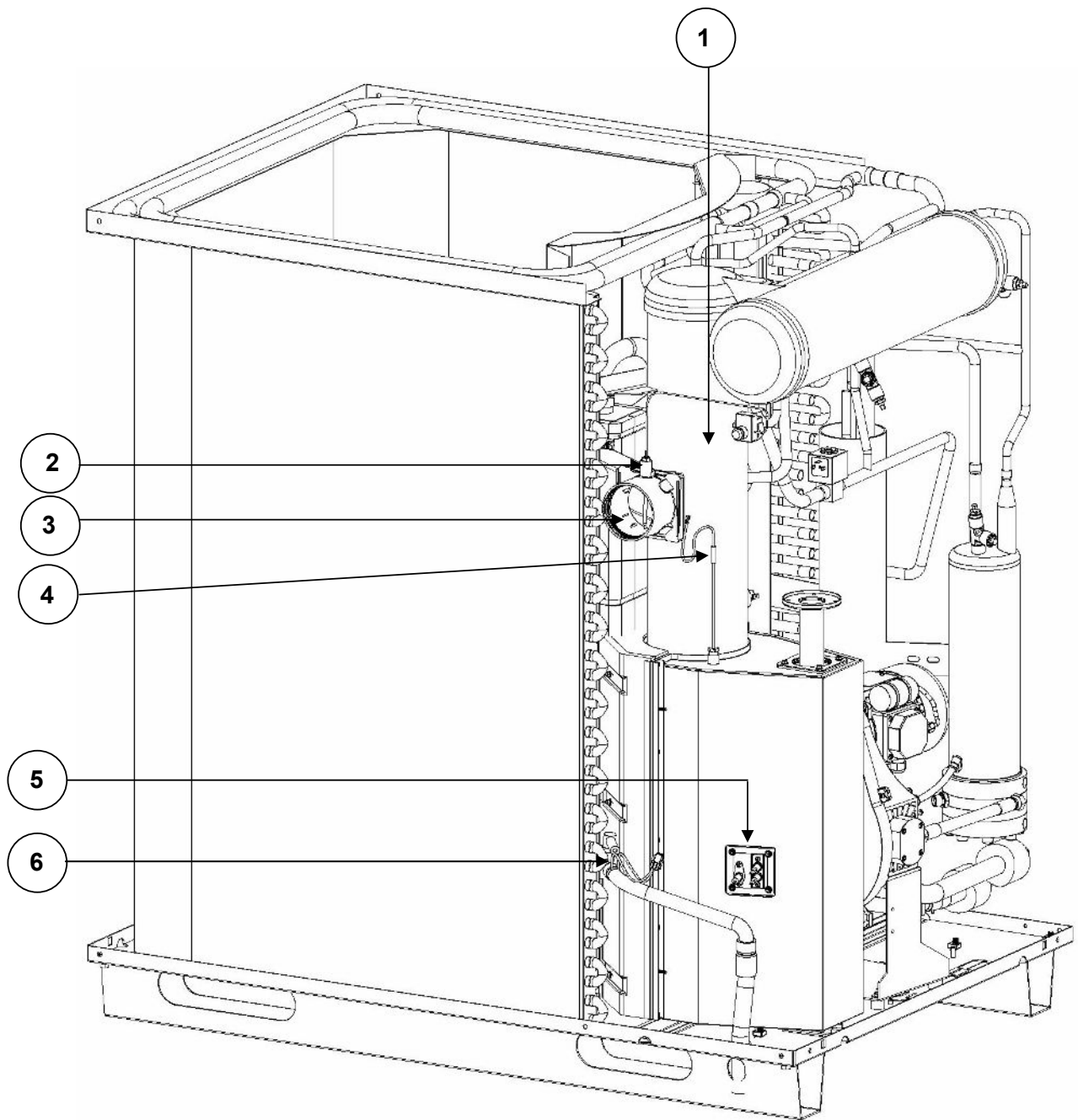

- 1 Manual reset of the flue exhaust thermostat
- 2 Sensing element of the flue exhaust thermostat
- 3 Ø 80mm flue gas exhaust
- 4 Generator fin temperature sensor
- 5 Flame sensor / ignition electrodes
- 6 Condensate level sensor

Figure 1.6 Internal components - right side view

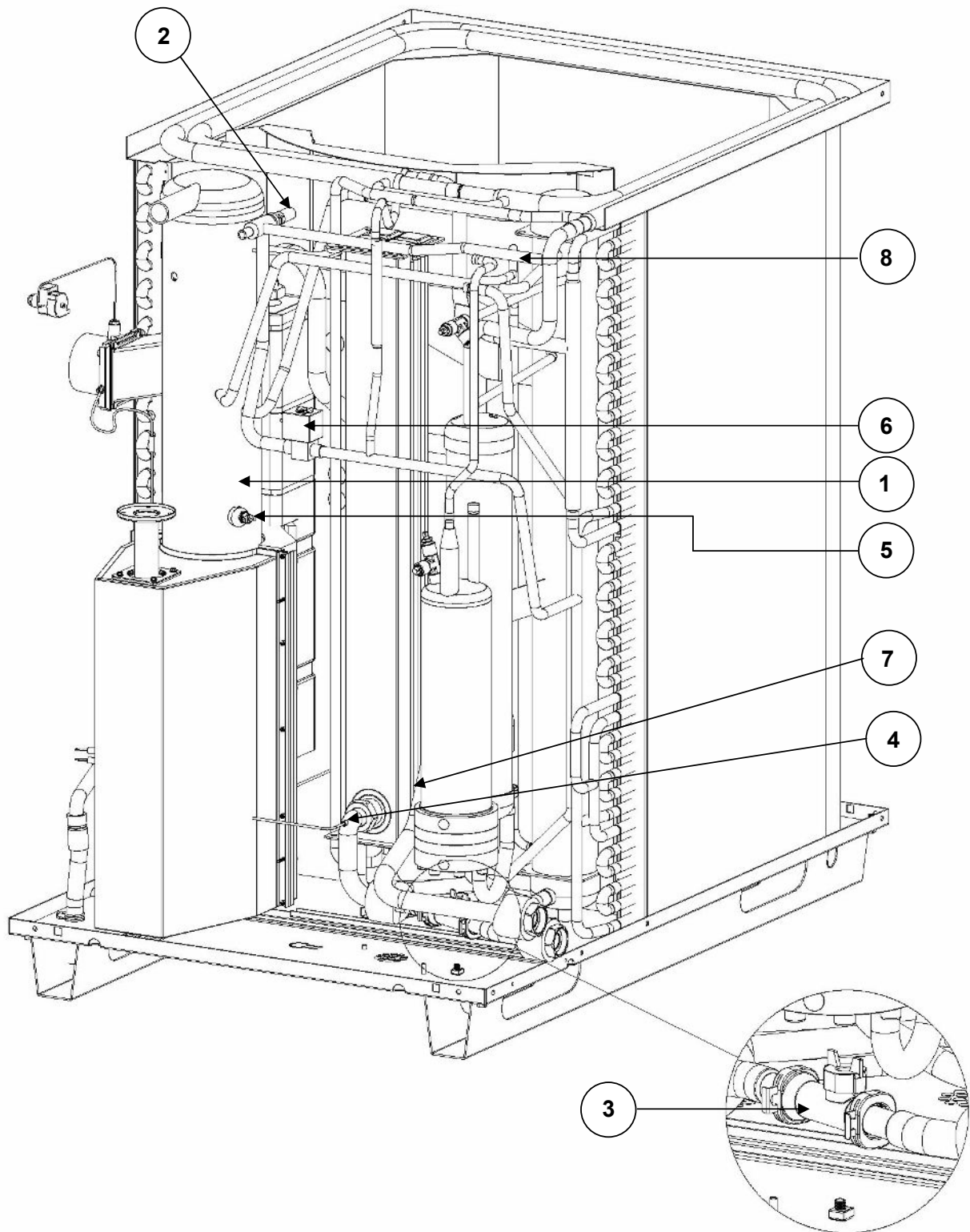

- 1 TG generator temperature probe
- 2 Safety valve
- 3 Delivery pipe flowmeter
- 4 Flow temperature probe
- 5 Limit thermostat
- 6 Defrosting valve
- 7 Return temperature probe
- 8 Teva evaporator temperature probe

1.4 ELECTRICAL WIRING DIAGRAM

Figure 1.7 Wiring diagram of the appliance with low consumption fan (S1)

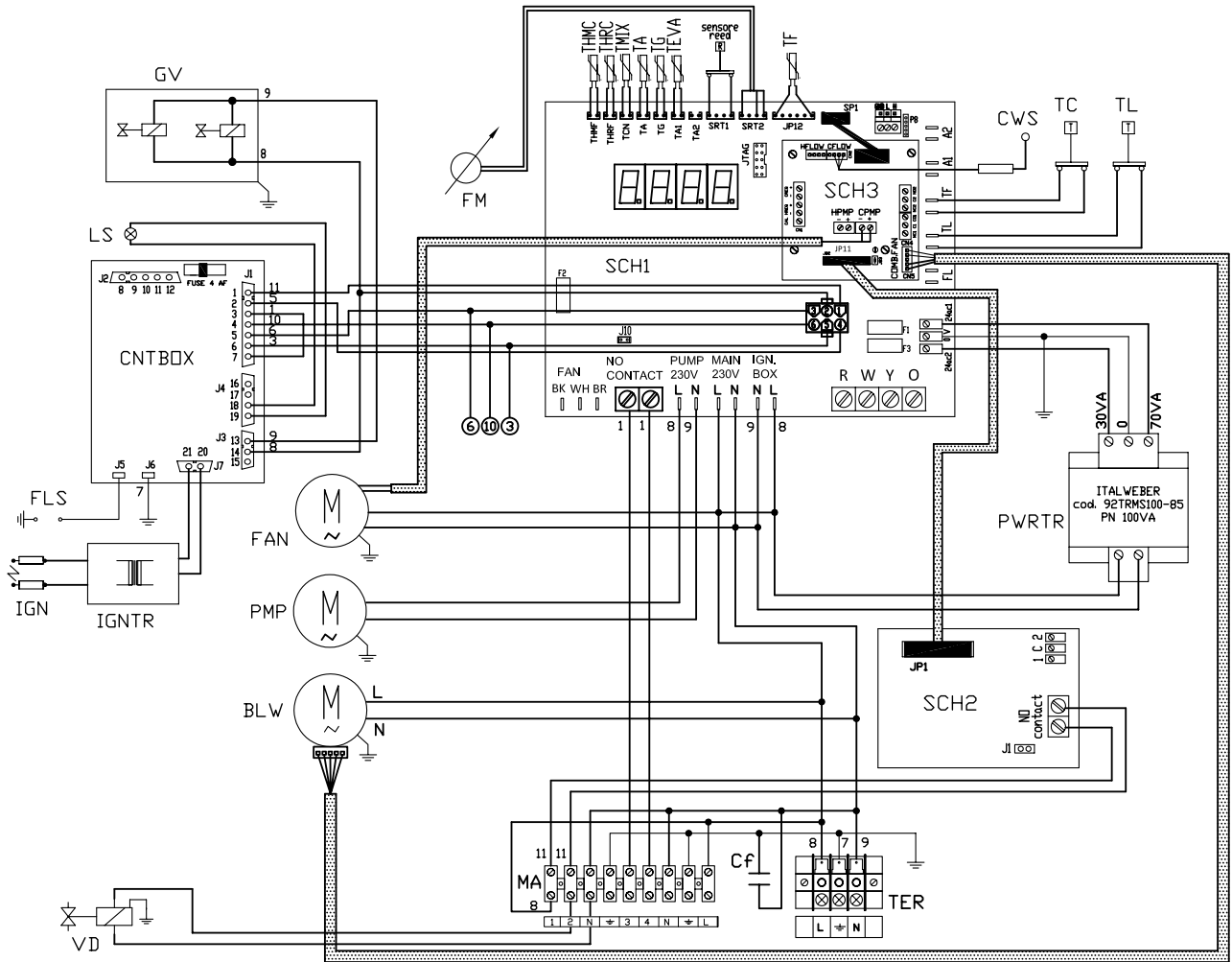

SCH1	Controller S61	FLS	Flame sensor	THRC	Hot water return temperature probe
SCH2	W10 circuit board	LS	Gas valve on indicator lamp	THMC	Hot water flow temperature probe
SCH3	Mod10 circuit board	GV	Gas solenoid valve	TMIX	Combustion air temperature sensor
TER	Appliance power terminal block	TC	Manual flue gas thermostat	TA	Ambient air temperature sensor
CNTBOX	Flame controller	TL	Generator limit thermostat	TG	Generator temperature sensor
PWRTR	Board transformer	FM	Flowmeter	TF	Fumes temperature sensor or generator fin sensor
BLW	Blower	CWS	Condensate water sensor	TEVA	Evaporator outlet temperature sensor
PMP	Oil pump	VD	Defrosting valve	MA	Terminal block
IGNTR	Ignition transformer	FAN	Fan	REED	Oil pump rotation sensor
IGN	Ignition electrodes	CF	Filter capacitor		

Figure 1.8 Wiring diagram of the appliance with standard fan

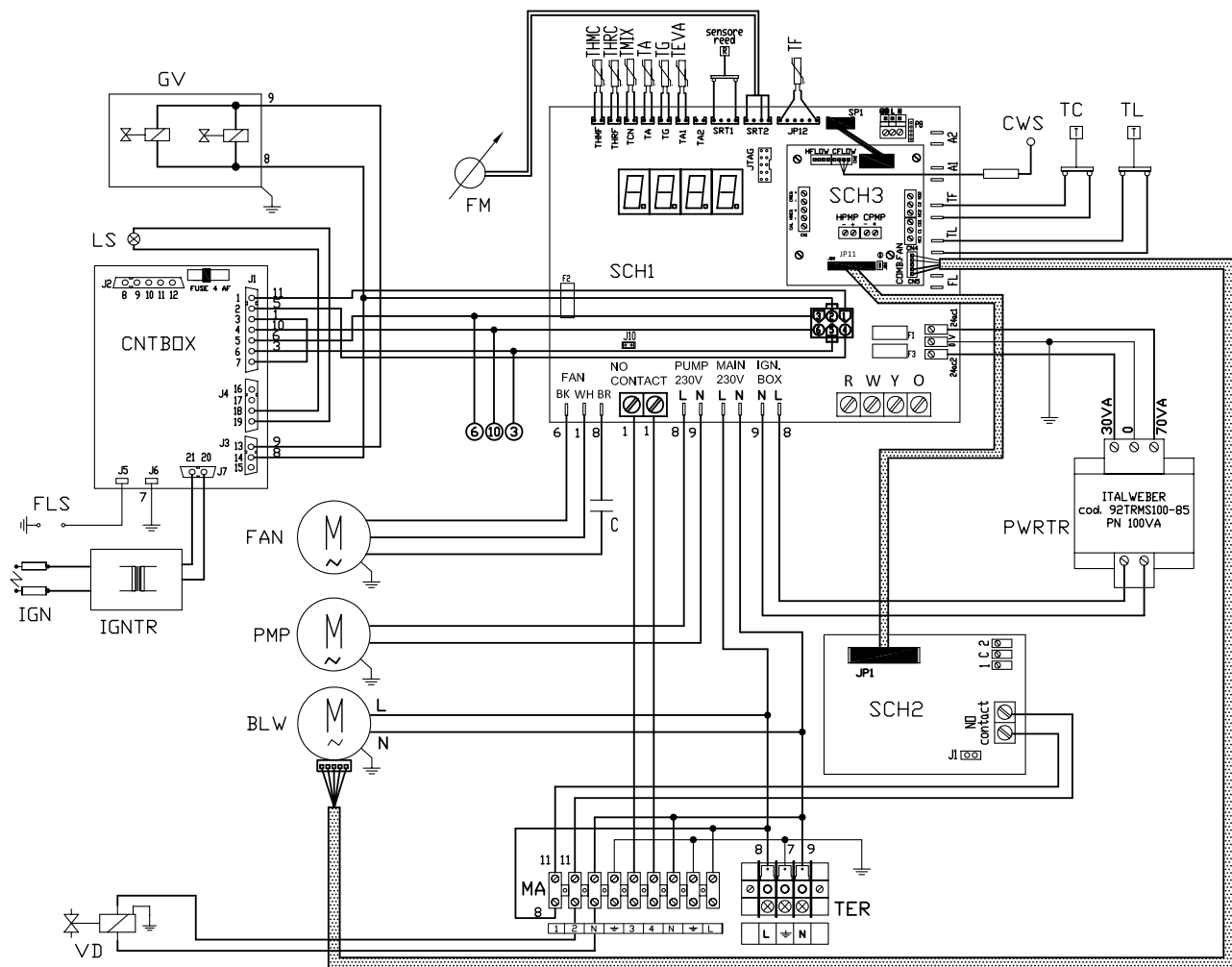

SCH1	Controller S61	LS	Gas valve on indicator lamp	THMC	Hot water flow temperature probe
SCH2	W10 circuit board	GV	Gas solenoid valve	TMIX	Combustion air temperature sensor
SCH3	Mod10 circuit board	TC	Manual flue gas thermostat	TA	Ambient air temperature sensor
TER	Appliance power terminal block	TL	Generator limit thermostat	TG	Generator temperature sensor
CNTBOX	Flame controller	FM	Flowmeter	TF	Fumes temperature sensor or generator fin sensor
PWRTR	Board transformer	CWS	Condensate water sensor	TEVA	Evaporator outlet temperature sensor
BLW	Blower	VD	Defrosting valve	MA	Terminal block
PMP	Oil pump	FAN	Fan	REED	Oil pump rotation sensor
IGNTR	Ignition transformer	C	Fan capacitor		
IGN	Ignition electrodes		(not in the low-noise unit)		
FLS	Flame sensor	THRC	Hot water return temperature probe		

1.5 ELECTRONIC BOARDS

Electronic boards (S61+Mod10)

The unit's electrical board contains:

- ▶ **Electronic Board S61** (Figure 1.9 p. 14), with microprocessor, it controls the appliance and displays data, messages and operative codes. The appliance is monitored and programmed by interacting with the display and knob.
- ▶ **Auxiliary Mod10 electronic board** (Figure 1.10 p. 15), overlapping S61, it handles power modulation of the burner,

fan and water circulation pump.

- ▶ **Satellite W10 electronic board** (Figure 1.11 p. 15), interconnected to the S61 board and located next to it, used to control defrosting operations of the GAHP unit.

Figure 1.9 Electronic board S61

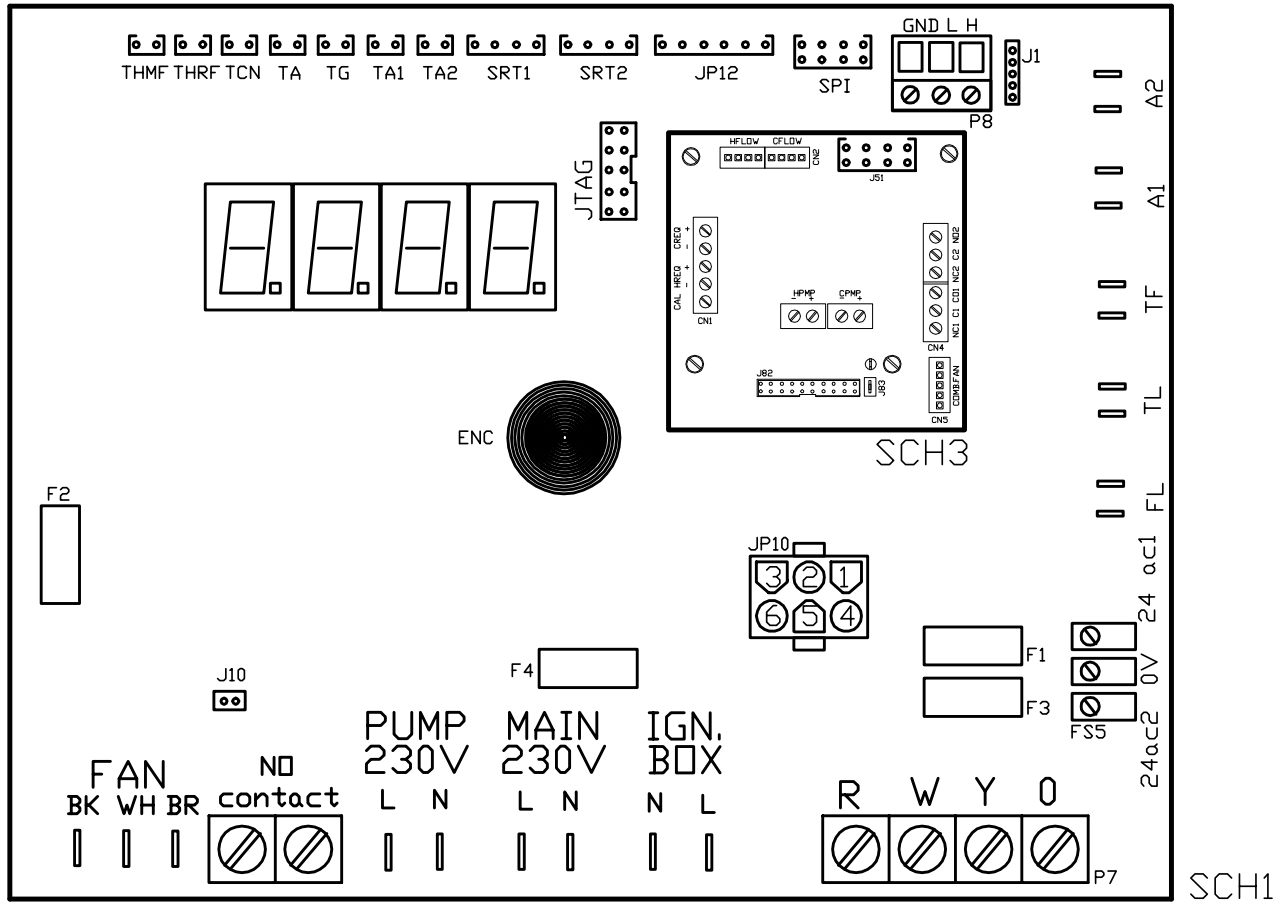

SCH1	Controller S61	IGN.BOX (L, N)	Flame controller power supply 230 Vac	P8	(GND, L, H) CAN bus connector
SCH3	Mod10 electronic board (see specific figure for further details)	J1	CAN bus Jumper	PUMP	230V (L, N) Oil pump supply output
A1, A2	Auxiliary inputs	J10	Jumper N.O. contact	SPI	Communication port with Mod10 controller
ENC	Knob	J82	W10 board connector (on Mod10)	SRT1	Oil pump rotation sensor input
F1	T 2A fuse	JP10	6-pole flame controller connector	SRT2	Hot water flowmeter input
F2	T 10A fuse	JP12	Flue gas probe or generator fin probe input	TA	Ambient air temperature probe input
F3	T 2A fuse	JTAG	S61 board programming connector	TA1	Evaporator output probe input
F4	T 3,15A fuse	MAIN	230V (L, N) S61 board supply input 230 Vac	TA2	Not used
FAN	(BK, WH, BR) Fan output	N.O. CONTACT	Normally open pump contact	TCN	Combustion air temperature probe input
F55	(24V AC) board supply 24-0-24 Vac	P7	(R, W, Y, O) Enable input	TF	Flue gas thermostat input

Figure 1.10 Mod10 controller

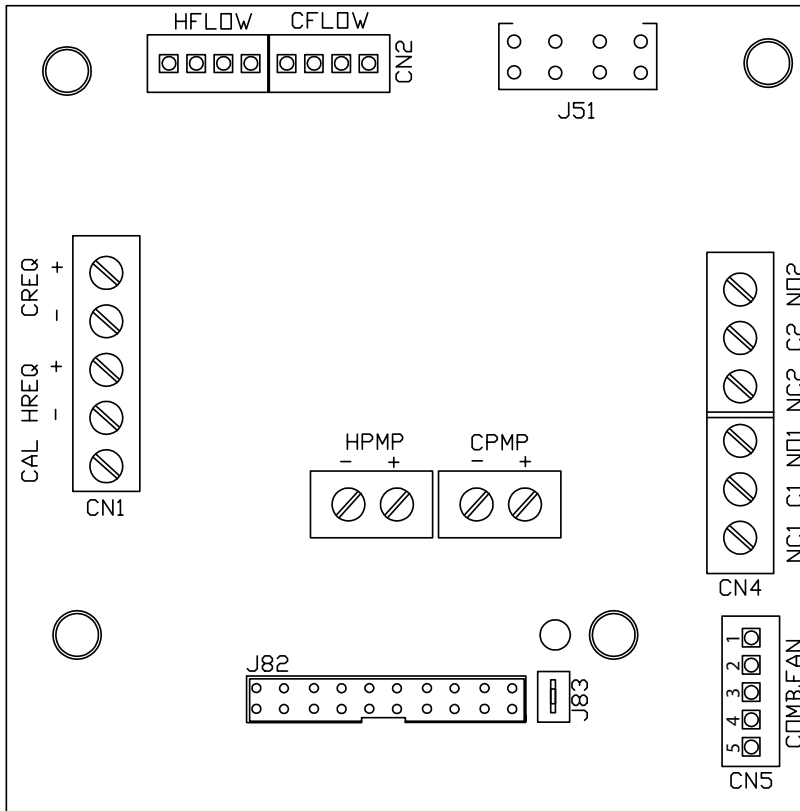

- HFLOW Not used
- CFLOW Condensation water sensor control
- J51 S61 connector
- HPMP Primary circuit hot water pump control output (0-10 V)
- CPMP S1 low consumption fan control output (0-10 V)
- NC1-C1 Status indication of locking warnig/error
- CN5 Blower control
- J82 W10 auxiliary controller connector
- J83 W10 cable shielding connection
- CN1 Inputs 0-10V (not used)

Figure 1.11 W10 electronic controller

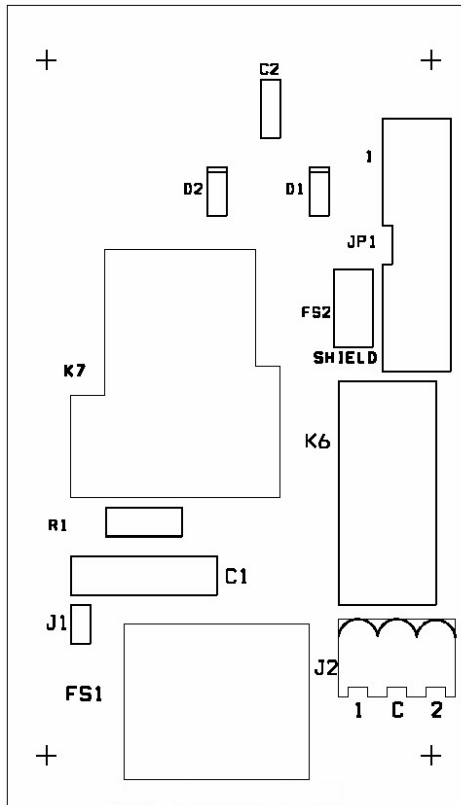

- FS1 Defrosting valve contact
- JP1 Communication with S61/Mod10

1.6 OPERATION MODE

ON/OFF or modulating operation

The GAHP unit may work in two modes:

- ▶ Mode (1) ON/OFF, i.e. On (at full power) or Off, with circulating pump at constant or variable flow.
- ▶ Mode (2) MODULATING, i.e. at variable load from 50% to 100% of heating capacity, with circulating pump at variable flow.

For each mode, (1) or (2), specific control systems and devices are provided (Paragraph 1.5 p. 13).

1.7 CONTROLS

Control device

The appliance may only work if it is connected to a control device, selected from:

- ▶ (1) **DDC control**
- ▶ (2) **CCP/CCI control**
- ▶ (3) **external request**

1.7.1 Control system (1) with DDC (GAHP unit ON/OFF)

The DDC controller is able to control appliances, a single GAHP unit, or even several Lochinvar GAHP/GA/AY units in cascade, only in ON/OFF mode (non modulating). For more details refer to the DDC, RB100, RB200 Manuals and the Design Manual.

DDC Controller

The main functions are:

- ▶ Setup and control of one (or more) Lochinvar units of the absorption line (GAHP, GA, AY).

- ▶ Data display and parameters setting.
- ▶ Hourly programming.
- ▶ Climate curve control.
- ▶ Diagnostics.
- ▶ Errors reset.
- ▶ Possibility to interface with a BMS.

DDC functionality may be extended with auxiliary Lochinvar devices RB100 and RB200 (e.g. service requests, DHW production, Third Party generator control, probe control, system valves or circulating pumps, ...).

1.7.2 Control system (2) with CCP/CCI (modulating GAHP unit)

The CCP/CCI control is able to control up to 3 GAHP units in modulating mode (therefore A/WS/GS only, excluding AR/ACF/AY), plus any integration ON/OFF boiler. For additional details and diagrams refer to the CCP/CCI Manual and the Design Manual.

CCP/CCI Control

See CCP/CCI device Manual.

1.7.3 Adjustment system (3) with external request (GAHP unit ON/OFF)

The appliance may also be controlled via generic request devices (e.g. thermostat, timer, button, contactor...) fitted with voltage-free NO contact. This system only provides elementary control (on/off, with fixed set-point temperature), hence without the important functions of systems (1) and (2). It is advisable to possibly limit its use to simple applications only and with a single appliance.



For connection of the selected device to the appliance's electronic board please refer to Paragraph 4.4 p. 26.

1.8 TECHNICAL CHARACTERISTICS

Table 1.1 GAHP A HT technical data

			GAHP A HT Standard	GAHP A HT S1
Heating mode				
Seasonal space heating energy efficiency class (ErP)	medium-temperature application (55 °C)	-	A+	
	low-temperature application (35 °C)	-	A+	
Heat output	Outdoor temperature/Delivery temperature	A7W35	kW	41,3
		A7W50	kW	38,3
		A7W65	kW	31,1
		A-7W50	kW	32,0
GUE efficiency	Outdoor temperature/Delivery temperature	A7W35	%	164
		A7W50	%	152
		A7W65	%	124
		A-7W50	%	127
Heat input	nominal (1013 mbar - 15 °C) (1)	kW	25,7	
	real	kW	25,2	
Hot water delivery temperature	maximum for heating	°C	65	
	maximum for DHW	°C	70	

(1) Relative to NCV (net calorific value).

(2) In transient operation, lower temperatures are allowed.

(3) For flows other than nominal see Design Manual, Pressure losses Paragraph.

(4) As an option, a version for operation down to -30 °C is available.

(5) ±10% depending on power voltage and absorption tolerance of electric motors.

(6) PCI (G20) 34,02 MJ/m³ (15 °C - 1013 mbar).

(7) PCI (G25) 29,25 MJ/m³ (15 °C - 1013 mbar).

(8) PCI (G27) 27,89 MJ/m³ (15 °C - 1013 mbar).

(9) PCI (G30/G31) 46,34 MJ/kg (15 °C - 1013 mbar).

(10) Sound power values detected in compliance with the intensity measurement methodology set forth by standard EN ISO 9614. Data referred to 50 °C delivery temperature.

(11) Maximum sound pressure levels in free field, with directionality factor 2, obtained from the sound power level in compliance with standard EN ISO 9614. Data referred to 50 °C delivery temperature.

(12) Overall dimensions excluding fumes pipes.

			GAHP A HT Standard	GAHP A HT S1
Hot water return temperature	maximum for heating	°C	55	
	maximum for DHW	°C	60	
	minimum temperature in continuous operation	°C	30 (2)	
Thermal differential	nominal	°C	10	
Heating water flow	nominal	l/h	2500	
	maximum	l/h	4000	
	minimum	l/h	1400	
Pressure drop heating mode	nominal water pressure (A7W50)	bar	0,31 (3)	
Ambient air temperature (dry bulb)	maximum	°C	45	
	minimum	°C	-15 (4)	
Electrical specifications				
Power supply	voltage	V	230	
	type	-	SINGLE PHASE	
	frequency	Hz	50	
Electrical power absorption	nominal	kW	0,84 (5)	0,77 (5)
	minimum	kW	-	0,50 (5)
Degree of protection	IP	-	X5D	
Installation data				
Gas consumption	G20 natural gas (nominal)	m ³ /h	2,72 (6)	
	G20 natural gas (min)	m ³ /h	1,34	
	G25 (nominal)	m ³ /h	3,16 (7)	
	G25 (min)	m ³ /h	1,57	
	G27 (nominal)	m ³ /h	3,32 (8)	
	G27 (min)	m ³ /h	1,62	
	G30 (nominal)	kg/h	2,03 (9)	
	G30 (min)	kg/h	0,99	
	G31 (nominal)	kg/h	2,00 (9)	
G31 (min)	kg/h	0,98		
NO_x emission class		-	5	
NO_x emission		ppm	25,0	
CO emission		ppm	36,0	
sound power L_w (max)		dB(A)	79,6 (10)	74,0 (10)
sound power L_w (min)		dB(A)	-	71,0 (10)
sound pressure L_p at 5 metres (max)		dB(A)	57,6 (11)	52,0 (11)
sound pressure L_p at 5 metres (min)		dB(A)	-	49,0 (11)
minimum storage temperature		°C	-30	
maximum water pressure in operation		bar	4	
maximum flow flue condensate		l/h	4,0	
Water content inside the apparatus		l	4	
Water fitting	type	-	F	
	thread	"	1 1/4	
Gas connection	type	-	F	
	thread	"	3/4	
Flue gas exhaust	diameter (Ø)	mm	80	
	residual head	Pa	80	
type of installation		-	B23P, B33, B53P	
Dimensions	width	mm	854 (12)	
	depth	mm	1260	
	height	mm	1445 (12)	1540
Weight	in operation	kg	390	400
required air flow		m ³ /h	11000	
fan residual head		Pa	40	
General information				
Cooling fluid	ammonia R717	kg	7,0	
	water H ₂ O	kg	10,0	
maximum pressure of the cooling circuit		bar	32	

(1) Relative to NCV (net calorific value).

(2) In transient operation, lower temperatures are allowed.

(3) For flows other than nominal see Design Manual, Pressure losses Paragraph.

(4) As an option, a version for operation down to -30 °C is available.

(5) ±10% depending on power voltage and absorption tolerance of electric motors.

(6) PCI (G20) 34,02 MJ/m³ (15 °C - 1013 mbar).

(7) PCI (G25) 29,25 MJ/m³ (15 °C - 1013 mbar).

(8) PCI (G27) 27,89 MJ/m³ (15 °C - 1013 mbar).

(9) PCI (G30/G31) 46,34 MJ/kg (15 °C - 1013 mbar).

(10) Sound power values detected in compliance with the intensity measurement methodology set forth by standard EN ISO 9614. Data referred to 50 °C delivery temperature.

(11) Maximum sound pressure levels in free field, with directionality factor 2, obtained from the sound power level in compliance with standard EN ISO 9614. Data referred to 50 °C delivery temperature.

(12) Overall dimensions excluding fumes pipes.

Table 1.2 PED data

PED data		GAHP A HT S1	GAHP A HT Standard
Components under pression	generator	l	18,6
	leveling chamber	l	11,5
	evaporator	l	3,7
	cooling volume transformer	l	4,5
	cooling absorber solution	l	6,3
	solution pump	l	3,3
test pressure (in air)	bar g	55	55
maximum pressure of the cooling circuit	bar g	32	32
filling ratio	kg of NH ₃ /l	0,146	0,146
fluid group	-	GROUP 1°	GROUP 1°

2 TRANSPORT AND POSITIONING

2.1 WARNINGS

i **Damage from transport or installation**

The manufacturer shall not be liable for any damage during appliance transport and installation.

i **On-site inspection**

- Upon arrival at the site, ensure there is no transport damage on packing, metal panels or finned coil.
- After removing the packing materials, ensure the appliance is intact and complete.

! **Packing**

- Only remove the packing after placing the appliance on site.
- Do not leave parts of the packing within the reach of children (plastic, polystyrene, nails...) since they are potentially dangerous.

! **Weight**

- The crane and lifting equipment must be suitable for the load.
- Do not stand under suspended loads.

2.2 HANDLING

Handling and lifting

- ▶ Always handle the appliance in its packing, as delivered by the factory.
- ▶ To lift the appliance use straps or slings inserted in the holes of the base (Figure 2.1 p. 18).
- ▶ Use lifting beams to avoid damaging the outer panels and finned coil (Figure 2.1 p. 18).
- ▶ Comply with safety regulations at the installation site.

Figure 2.1 Instruction for lifting

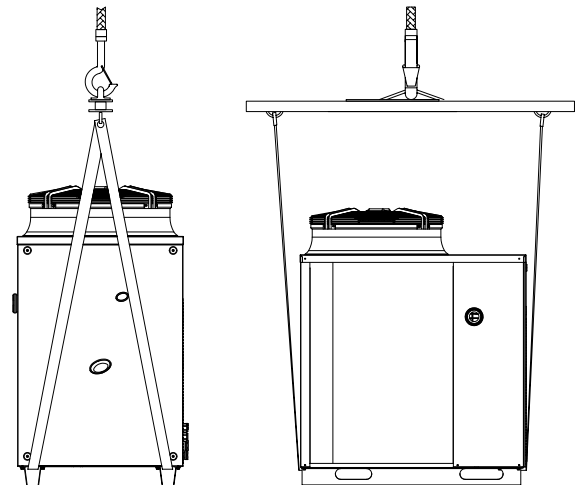

i In the event of handling with forklift or pallet truck, comply with the handling instructions shown on the packing.

2.3 APPLIANCE POSITIONING

! **Do not install inside a room**

- The appliance is type-approved for external installation.
- Do not install inside a room, not even if it has openings.
- In no event start the appliance inside a room.

i **GAHP A unit ventilation**

- The athermic appliance requires a large space, ventilated and free from obstacles, to enable smooth flow of air to the finned coil and free air outlet above the mouth of the fan, with no air recirculation.
- Incorrect ventilation may affect efficiency and cause damage to the appliance.
- The manufacturer shall not be liable for any incorrect choices of the place and setting of installation.

Where to install the appliance

- ▶ The appliance may be installed at ground level, on a terrace

- ▶ or on a roof, compatibly with its dimensions and weight.
- ▶ It must be installed outside buildings, in an area of natural air circulation, outside the dripping path of drainpipes or similar. It does not require protection from weathering.
- ▶ No obstruction or overhanging structure (e.g. protruding roofs, canopies, balconies, ledges, trees) shall interfere either with the air flowing from the top of the appliance or with the exhaust flue gas.
- ▶ The appliance's flue gas exhaust must not be immediately close to openings or air intakes of buildings, and must comply with environmental regulations.
- ▶ Do not install near the exhaust of flues, chimneys or hot polluted air. In order to work correctly, the appliance needs clean air.

Defrosting water drainage

i In winter, it is normal for frost to form on the finned coil and for the appliance to perform defrosting cycles.

- To prevent overflowing and damage provide for a drainage system.

Acoustic issues

- ▶ Pre-emptively assess the appliance's sound effect in connection to the site, taking into account that building corners, enclosed courtyards, restricted spaces may amplify the acoustic impact due to the reverberation phenomenon.

2.4 MINIMUM CLEARANCE DISTANCES

Distances from combustible or flammable materials

- ▶ Keep the appliance away from combustible or flammable materials or components, in compliance with applicable regulations.

Clearances around the appliance

The **minimum clearance distances** shown in Figure 2.2 p. 19 (bar any stricter regulations) are required for safety, operation and maintenance.

Figure 2.2 Clearances

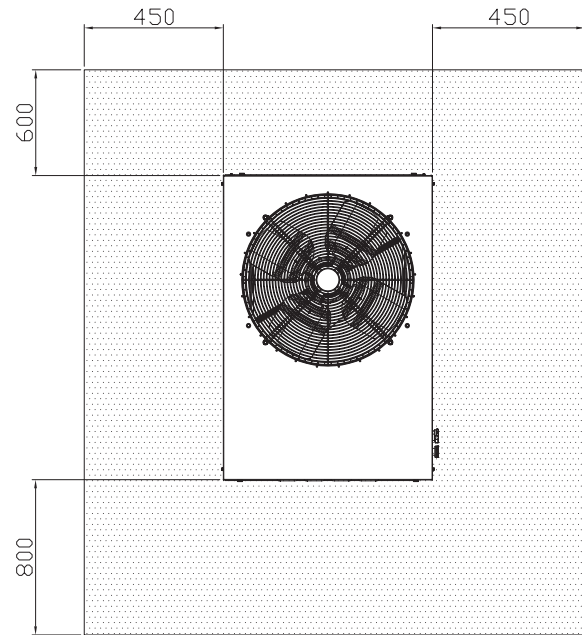

2.5 MOUNTING BASE

Mounting base constructive features

- ▶ Place the appliance on a levelled flat surface made of fire-proof material and able to withstand its weight.

(1) - installation at ground level

- ▶ Failing a horizontal supporting base, make a flat and levelled concrete base, at least 100-150 mm larger than the appliance size per side.

(2) - installation on terrace or roof

- ▶ The structure of the building must support the total weight of the appliance and the supporting base.
- ▶ If necessary, provide a maintenance walkway around the appliance.

Anti vibration mountings

Although the appliance's vibrations are minimal, resonance phenomena might occur in roof or terrace installations.

- ▶ Use anti-vibration mountings.
- ▶ Also provide anti-vibration joints between the appliance and water and gas pipes.

3 HEATING ENGINEER

3.1 WARNINGS

General warnings

! Read the warnings in Chapter III.1 p. 4, providing important information on regulations and on safety.

i Compliance with installation standards

Installation must comply with applicable regulations in force, based on the installation Country and site, in

matters of safety, design, implementation and maintenance of:

- heating systems
- cooling systems
- gas systems
- flue gas exhaust
- flue gas condensate discharge

i Installation must also comply with the manufacturer's provisions.

3.2 HYDRAULIC SYSTEM

Primary and secondary circuit

- ▶ In many cases it is advisable to divide the hydraulic system into two parts, primary and secondary circuit, uncoupled by a hydraulic separator, or possibly by a tank that also acts as inertial tank/buffer.

Constant or variable water flow

The GAHP unit may work with constant or variable water flow, regardless of the ON/OFF or modulating operative mode. System and components must be designed and installed consistently.

Minimum water content

High thermal inertia is conducive to efficient appliance operation. Very short ON/OFF cycles are to be avoided.

- ▶ If necessary, provide for an inertial volume, to be suitably sized (see design manual).

3.3 HYDRAULIC CONNECTIONS

Plumbing fittings

on the right, at the bottom, **connection plate** (Figure 1.1 p. 7).

- ▶ A (= out) 1 1/4" F - WATER OUTLET (hot) (m = delivery to the

system)

- ▶ B (= in) 1 1/4" F - WATER INLET (r = return from the system)

Hydraulic pipes, materials and features

- ▶ Use pipes for heating/cooling systems, protected from weathering, insulated for thermal dispersion.

i Pipe cleaning

- Before connecting the appliance, accurately wash the water and gas piping and any other system component, removing any residue.

Minimum components of primary plumbing circuit

Always provide, near the appliance:

- ▶ on water piping, both output and input (m/r)
 - 2 antivibration joints on water fittings
 - 2 pressure gauges
 - 2 isolation ball valves
- ▶ on the input water piping (r)
 - 1 separator filter
 - 1 flow regulation valve, if the circulation pump is with constant flow
 - 1 water circulation pump, towards the appliance
- ▶ on the output water piping (m)
 - 1 safety valve (3 bar)
 - 1 expansion tank of the individual unit

Figure 3.1 Hydraulic plan

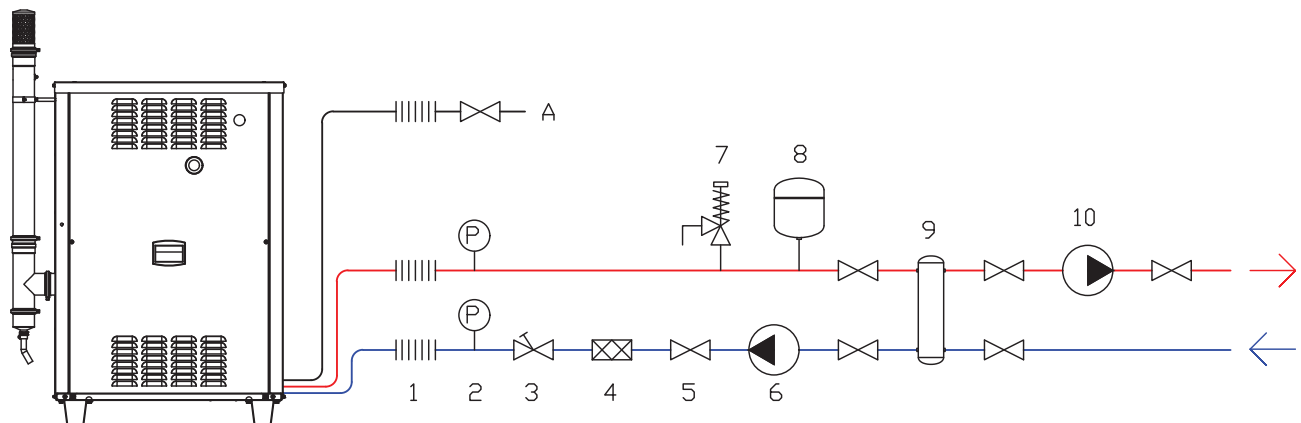

The flow regulator valve must only be used when the primary circuit circulation pump is constant flow type	2 Pressure gauge	7 Safety valve (3 bar)
A Gas connection	3 Flow regulator valve	8 Expansion tank
1 Anti-vibration connection	4 Water filter	9 Hydraulic separator / inertial tank with 4 fittings
	5 Shut-off valves	10 Water pump (secondary circuit)
	6 Water pump (primary circuit)	

3.4 WATER CIRCULATION PUMP

The circulation pump (flow and head) must be selected and installed based on pressure losses of plumbing/primary circuit (piping + components + exchange terminals + appliance).

For the appliance's pressure losses refer to Table 1.1 p. 16 and Design Manual.

(1) CONSTANT FLOW circulating pump

The primary circulating pump must be obligatorily controlled by the appliance's electronic board (S61) (see Paragraph 1.5 p. 13).

(2) VARIABLE FLOW circulating pump

For variable flow operation, use of a Wilo Stratos Para pump is

obligatory, supplied as accessory on demand, to be connected to the Mod10 electronic board (see Paragraph 1.5 p. 13). Any other type of pump will give constant flow.

Refer to the Design Manual for the features of the Wilo Stratos Para pump.

3.5 ANTIFREEZE FUNCTION

Active antifreeze self-protection

The appliance is equipped with an active antifreeze self-protection system to prevent icing. The anti-icing function (activated by default) automatically starts the primary circulation pump and, if required, the burner too, when the outside temperature

approaches zero.

Electrical and gas continuity

The active antifreeze self-protection is only effective if the power and gas supplies are assured. Otherwise, anti-freeze liquid might be required.

3.6 ANTIFREEZE LIQUID

Precautions with glycol

The manufacturer disclaims any liability for any damage caused by improper glycol use.

- Always check product suitability and its expiry date with the glycol supplier. Periodically check the product's preservation state.
- ▶ Do not use car-grade antifreeze liquid (without inhibitors), nor zinc-coated piping and fittings (incompatible with glycol).
 - Glycol modifies the physical properties of water (density,

viscosity, specific heat...). Size the piping, circulation pump and thermal generators accordingly.

- With automatic system water filling, a periodic check of the glycol content is required.

With high glycol percentage (> 20...30%)

If the glycol percentage is $\geq 30\%$ (for ethylene glycol) or $\geq 20\%$ (for propylene glycol) the TAC must be alerted before first start-up.



When producing DHW by DHW buffer tank, use propylene glycol only.

Type of antifreeze glycol

Inhibited type glycol is recommended to prevent oxidation phenomena.

Glycol effects

The Table 3.1 p. 21 shows, indicatively, the effects of using a glycol depending on its %.

Table 3.1 Technical data for filling the hydraulic circuit

GLYCOL %	WATER-GLYCOL MIXTURE FREEZING TEMPERATURE	PERCENTAGE OF INCREASE IN PRESSURE DROPS	LOSS OF EFFICIENCY OF UNIT
10	-3 °C	-	-
15	-5 °C	6,0%	0,5%
20	-8 °C	8,0%	1,0%
25	-12 °C	10,0%	2,0%
30	-15 °C	12,0%	2,5%
35	-20 °C	14,0%	3,0%
40	-25 °C	16,0%	4,0%

3.7 SYSTEM WATER QUALITY

Responsibility of the user/operator/installer

The installer, operator and user must assure system water quality (Table 3.2 p. 21). Failure to comply with the manufacturer's guidelines may affect operation, integrity and life of the appliance, voiding the warranty.

System water characteristics

Free chlorine or water hardness may damage the appliance. Adhere to the chemical-physical parameters in Table 3.2 p. 21 and the regulations on water treatment for residential and industrial heating systems.

Table 3.2 Chemical and physical parameters of water

CHEMICAL AND PHYSICAL PARAMETERS OF WATER IN HEATING/COOLING SYSTEMS		
PARAMETER	UNIT OF MEASUREMENT	ALLOWABLE RANGE
pH	/	> 7 (1)
Chlorides	mg/l	< 125 (2)
Total hardness (CaCO ₃)	°f	< 15
	°d	< 8,4
Iron	mg/kg	< 0,5 (3)
Copper	mg/kg	< 0,1 (3)
Aluminium	mg/l	< 1
Langelier's index	/	0-0,4
HARMFUL SUBSTANCES		
Free chlorine	mg/l	< 0,2 (3)
Fluorides	mg/l	< 1
Sulphides		ABSENT

- 1 with aluminium or light alloys radiators, pH must also be lower than 8 (in compliance with applicable rules)
- 2 value referred to the maximum water temperature of 80 °C
- 3 in compliance with applicable rules

Water topping up

The chemical-physical properties of the system's water may alter over time, resulting in poor operation or excessive topping up.

- ▶ Ensure there are no leaks in the installation.
- ▶ Periodically check the chemical-physical parameters of the water, particularly in case of automatic topping up.



Chemical conditioning and washing

Water treatment/conditioning or system washing carried out carelessly may result in risks for the appliance, the system, the environment and health.

- Contact specialised firms or professionals for water treatment or system washing.
- Check compatibility of treatment or washing products with operating conditions.
- Do not use aggressive substances for stainless steel or copper.
- Do not leave washing residues.

3.8 SYSTEM FILLING



How to fill up the system

After completing all water, electrical and gas connections:

1. Pressurise (at least 1.5 bar) and vent the hydraulic circuit.
2. Let water flow (with appliance off).
3. Check and clean the filter on the inlet pipe.
4. Repeat items 1, 2 and 3 until the pressure has stabilised (at least 1.5 bar).

3.9 FUEL GAS SUPPLY

Gas connection

- ▶ **3/4" F** on the right, at the bottom, **connection plate** (Figure 1.1 p. 7).
- ▶ Install an anti-vibration connection between the appliance and the gas piping.

Mandatory shut-off valve

- ▶ Provide a gas shut-off valve (manual) on the gas supply line, next to the appliance, to isolate it when required.
- ▶ Perform connection in compliance with applicable regulations.

Gas pipes sizing

The gas pipes must not cause excessive pressure drops and, consequently, insufficient gas pressure for the appliance.

Supply gas pressure



This appliance is equipped for a maximum gas supply pressure of 50 mbar.

The appliance's gas supply pressure, both static and dynamic, must comply with Table 3.3 p. 22, with tolerance $\pm 15\%$.



Non compliant gas pressure (Table 3.3 p. 22) may damage the appliance and be hazardous.

Table 3.3 Gas network pressure

Product category	Countries of destination	Gas supply pressure							
		G20 [mbar]	G25 [mbar]	G30 [mbar]	G31 [mbar]	G25.1 [mbar]	G25.3 [mbar]	G27 [mbar]	G2,350 [mbar]
II _{2H3B/P}	AL, BG, CY, CZ, DK, EE, FI, GR, HR, IT, LT, MK, NO, RO, SE, SI, SK, TR	20		30	30				
	AT, CH	20		50	50				
II _{2H3P}	BG, CH, CZ, ES, GB, HR, IE, IT, LT, MK, PT, SI, SK, TR	20			37				
	RO	20			30				
	AT	20			50				
II _{2ELL3B/P}	DE	20	20	50	50				
II _{2ES3P} ; II _{2Er3P}	FR	20	25		37				
II _{2HS3B/P}	HU	25		30	30	25 (1) (2)			
II _{2E3P}	LU	20			50				
II _{2L3B/P}	NL		25	30	30				
II _{2EK3B/P}	NL	20		30	30		25 (1) (2)		
II _{2E3B/P}		20		37	37				
II _{2ELWLS3B/P}	PL	20		37	37			20 (2)	13 (2)
II _{2ELWLS3P}		20			37			20 (2)	13 (2)
I _{2E(S)} ; I _{3P}	BE	20	25		37				
I _{3P}	IS				30				
I _{2H}	LV	20							
I _{3B/P}	MT			30	30				
				30					

(1) GAHP-AR not approved for G25.1, G25.3 gases.
 (2) GA ACF not approved for G25.1, G27, G2.350, G25.3 gases.

Vertical pipes and condensate

- ▶ Vertical gas pipes must be fitted with siphon and discharge of the condensate that may form inside the pipe.
- ▶ If necessary, insulate the piping.

LPG pressure reducers

With LPG the following must be installed:

- ▶ A first stage pressure reducer, close to the liquid gas tank.
- ▶ A second stage pressure reducer, close to the appliance.

3.10 COMBUSTION PRODUCTS EXHAUST

Compliance with standards

The appliance is approved for connection to a combustion products exhaust duct for the types shown in Table 1.1 p. 16.

Flue gas exhaust connection

- ▶ Ø 80 mm (with gasket), on the left, at the top (Figure 3.2 p. 23).

Flue gas exhaust kit

The appliance is supplied with flue gas exhaust kit, to be fitted by the installer, including (Figure 3.2 p. 23):

- ▶ 1 pipe Ø 80 mm, length 300 mm, with terminal and socket for flue gas analysis
- ▶ 1 support collar
- ▶ 1 90° elbow Ø 80 mm
- ▶ 1 rain cover

Figure 3.2 Flue gas exhaust

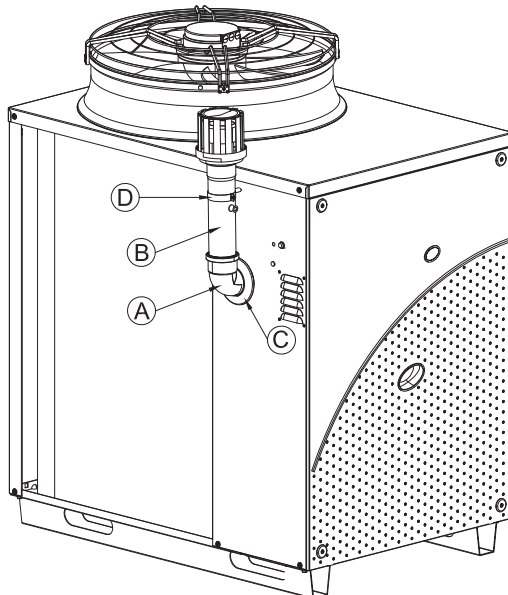

- A 90° elbow Ø 80
- B Pipe Ø 80 Lg.300 mm w/terminal
- C Rain cover
- D Collar



How to install the flue gas kit

Figure 3.2 p. 23:

1. Remove the front panel.
2. Fasten the collar (D) with its spacer to the left side panel of the appliance.
3. Fit the terminal/pipe assembly (B) to the elbow (A).
4. Fit the rain cover (C) onto the elbow (A).
5. Remove the protection cover.
6. Insert the elbow/terminal/pipe assembly into the flue gas exhaust.
7. Fit the assembly closing the collar (D) and place the rain cover.
8. Fit the front panel back on.



The cap prevents water and foreign bodies entering

the appliance before the fumes kit is installed. The cap should thus be removed only when the kit itself has been fully assembled and installed.

Possible flue

If necessary, the appliance may be connected to a flue.

- ▶ To size the flue refer to Table 1.1 p. 16 and Design Manual.
- ▶ If several appliances are connected to a single flue, it is obligatory to install a check valve on the exhaust of each.
- ▶ The flue must be designed, sized, tested and constructed by a skilled form, with materials and components complying with the regulations in force in the country of installation.
- ▶ Always provide a socket for flue gas analysis, in an accessible position.

3.11 FLUE GAS CONDENSATE DISCHARGE

The GAHP A unit is a condensing appliance and therefore produces condensation water from combustion flue gases.

Condensate acidity and exhaust regulations

The flue gas condensate contains aggressive acid substances. Refer to applicable regulations in force for condensate exhaust and disposal.

- If required, install an acidity neutraliser of adequate capacity.

Do not use gutters to discharge the condensate

Do not discharge the fume condensate in gutters, due to the risk of materials corrosion and ice formation.

Flue gas condensate connection

The fitting for flue gas condensate discharge is located on the left side of the appliance (Figure 3.3 p. 24).

- ▶ The distance L between the sleeve and the base must not exceed 110 mm.
- ▶ The corrugated condensate discharge pipe must be connected to a suitable discharge manifold.
- ▶ The junction between the pipe and the manifold must remain visible.
- ▶ The connection of the discharge to the sewerage system must be made at atmospheric pressure, i.e. by dripping into a siphoned container connected to the sewerage system.

Flue gas condensate discharge manifold

To make the condensate discharge manifold:

- ▶ Size the ducts for maximum condensation capacity (Table 1.1 p. 16).
- ▶ Use plastic materials resistant to acidity pH 3-5.
- ▶ Provide for min. 1% slope, i.e. 1 cm for each m of the length (otherwise a booster pump is required).
- ▶ Prevent icing.
- ▶ Dilute, if possible, with domestic waste water (e.g. bathrooms, washing machines, dish washers...), basic and neutralising.

Figure 3.3 Condensate drain position

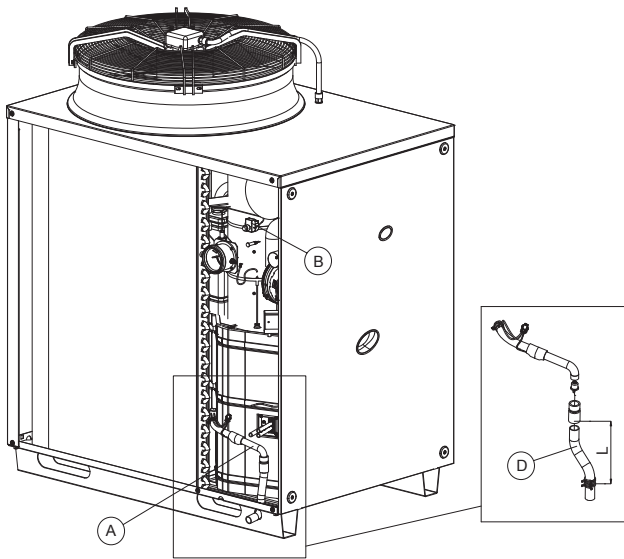

- A Condensate discharge hose
- D Corrugated hose

3.12 DEFROSTING WATER DRAINAGE

i Defrosting

In winter, frost may form on the finned coil and the appliance performs defrosting cycles.

Collection basin and drainage system

- ▶ Provide for a collection basin or containment rim and a discharge system of the defrosting water, to avoid overflowing, icing and damage.

4 ELECTRICAL INSTALLER

4.1 WARNINGS

i General warnings

Read the warnings in Chapter III.1 p. 4, providing important information on regulations and on safety.

i Compliance with installation standards

Installation must comply with applicable regulations in force, based on the installation Country and site, in matters of safety, design, implementation and maintenance of electrical systems.

i Installation must also comply with the manufacturer's provisions.

! Live components

- After placing the appliance in the final position, and prior to making electrical connections, ensure not to work on live components.

! Earthing

- The appliance must be connected to an effective earthing system, installed in compliance with regulations in force.
- It is forbidden to use gas pipes as earthing.

i Cable segregation

Keep power cables physically separate from signal ones.

! Do not use the power supply switch to turn the appliance on/off

- Never use the external isolation switch (GS) to turn the appliance on and off, since it may be damaged in the long run (occasional blackouts are tolerated).
- To turn the appliance on and off, exclusively use the suitably provided control device (DDC, CCP/CCI or external request).

! Control of water circulation pump

The water circulation pump of the hydraulic/primary circuit must mandatorily be controlled by the unit's electronic boards (S61 + Mod10). It is not admissible to start/stop the circulating pump with no enable from the appliance.

4.2 ELECTRICAL SYSTEMS

Electrical connections must provide:

- ▶ (a) power supply (Paragraph 4.3 p. 25)
- ▶ (b) control system (Paragraph 4.4 p. 26)

Figure 4.1 Electrical panel

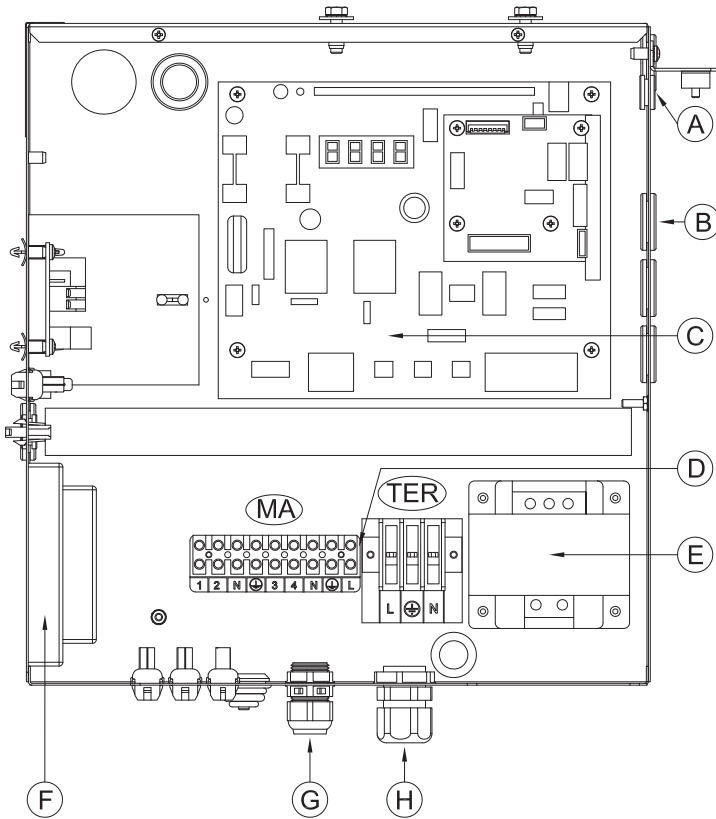

- A CAN bus cable gland
 - B Signal cable gland 0...10 V pump Wilo Stratos Para
 - C Electronic boards S61+Mod10+W10
 - D Terminal boxes
 - E Transformer 230/23 V AC
 - F Flame control unit
 - G Circulation pump power supply and control cable gland
 - H GAHP power supply cable gland
- Terminals:
- TER terminal box
 - L-(PE)-N Phase/earth/neutral GA power supply
 - MA terminal box
 - N-(PE)-L Neutral/earth/phase circulation pump power supply
 - 3-4 Circulation pump enable



How to make connections

All electrical connections must be made in the appliance's electrical panel (Figure 4.1 p. 25):

1. Ensure the appliance's electrical panel is not live.
2. Remove the front panel of the appliance and the cover of the electrical panel.
3. Run the cables through the suitable holes in the connection plate.
4. Run the cables through the suitable cable glands in the electrical panel.
5. Identify the appropriate connection terminals.
6. Make the connections.
7. Close the electrical panel and fit the front panel back on.

4.3 ELECTRICAL POWER SUPPLY

Power supply line

Provide (by the installer) a protected single phase line (230 V 1-N 50 Hz) with:

- ▶ 1 three-pole cable type FG7(O)R 3Gx1.5
- ▶ 1 two-pole switch with two 5A type T fuses, (GS) or one 10A magnetothermic breaker

Figure 4.2 Electrical wiring diagram - Example of connection of appliance to 230 V 1 N - 50 Hz electricity supply

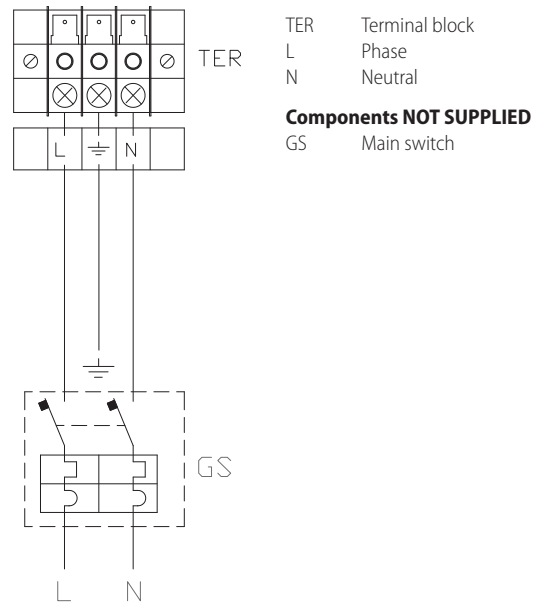

The switches must also provide disconnecter capability, with min contact opening 4 mm.



How to connect the power supply

To connect the three-pole power supply cable (Figure 4.2 p. 25):

1. Access the electrical board of the appliance according to the Procedure 4.2 p. 24.

2. Connect the three lead-in wires to the terminal block (TER) in the electrical panel on the machine.
3. Provide the earth lead-in wire longer than live ones (last to be torn in the event of accidental pulling).

4.4 SET-UP AND CONTROL

Control systems, options (1) (2) (3)

Three separate adjustment systems are provided, each with specific features, components and diagrams (see 4.4 p. 27, 4.5 p. 27):

- ▶ System (1), with **DDC control** (with CAN bus connection).
- ▶ System (2), with **CCP/CCI control** (with CAN bus connection).
- ▶ System (3), with an **external request**.

CAN bus communication network

The CAN bus communication network, implemented with the

cable of the same name, makes it possible to connect and remotely control one or more Lochinvar appliances with the DDC or CCP/CCI control devices.

It entails a certain number of serial nodes, distinguished in:

- ▶ Intermediate nodes, in variable number.
 - ▶ Terminal nodes, always and only two (beginning and end).
- Each component of the Lochinvar system, appliance (GAHP, GA, AY, ...) or control device (DDC, RB100, RB200, CCI, ...), corresponds to a node, connected to two more elements (if it is an intermediate node) or to just one other element (if it is a terminal node) through two/one CAN bus cable section/s, forming an open linear communication network (never star or loop-shaped).

CAN bus signal cable

The DDC or CCP/CCI controllers are connected to the appliance through the CAN bus signal cable, shielded, compliant to Table 4.1 p. 26 (admissible types and maximum distances).

For lengths ≤200 m and max 4 nodes (e.g. 1 DDC + 3 GAHP), a simple 3x0.75 mm shielded cable may even be used.

Table 4.1 CAN bus cables type

CABLE NAME	SIGNALS / COLOR			MAX LENGTH	Note	
Robur						
ROBUR NETBUS	H= BLACK	L= WHITE	GND= BROWN	450 m	Ordering Code OCVO008	
Honeywell SDS 1620						
BELDEN 3086A	H= BLACK	L= WHITE	GND= BROWN	450 m	In all cases the fourth conductor should not be used	
TURCK type 530						
DeviceNet Mid Cable						
TURCK type 5711	H= BLUE	L= WHITE	GND= BLACK	450 m		
Honeywell SDS 2022						
TURCK type 531	H= BLACK	L= WHITE	GND= BROWN	200 m		



How to connect the CAN bus cable to the appliance

To connect the CAN bus cable to the S61 electronic board (Paragraph 1.5 p. 13), located in the electrical panel inside the unit, (Figure 4.3 p. 26 and 4.4 p. 27):

1. Access the electrical panel of the appliance according to the Procedure 4.2 p. 24.
2. Connect the CAN bus cable to the GND (shielding/earthing) + L and H terminals (two signal wires).
3. Place the CLOSED J1 Jumpers (Detail A) if the node is terminal (one connected CAN bus cable section only), or OPEN (Detail B) if the node is intermediate (two connected CAN bus cable sections).
4. Connect the DDC or the CCP/CCI to the CAN bus cable according to the instructions in the following Paragraphs and the DDC or CCP/CCI Manuals.

Figure 4.3 Electrical wiring diagram - Connection cable CAN bus to electronic board

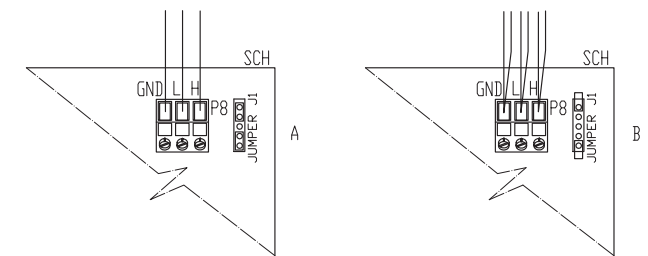

- SCH Electronic board
- GND Common data
- L Data signal LOW
- H Data signal HIGH
- J1 Jumper CAN bus in board
- A detail of "terminal node" case (3 wires; J1=jumper "closed")
- B Detail of "intermediate node" case (6 wires; J1=jumper "open")
- P8 CAN port/connector

GAHP Configuration (S61) + DDC or CCP/CCI

(Systems (1) and (2) see also Paragraph 1.7 p. 16)

Figure 4.4 CAN bus connection for systems with one unit

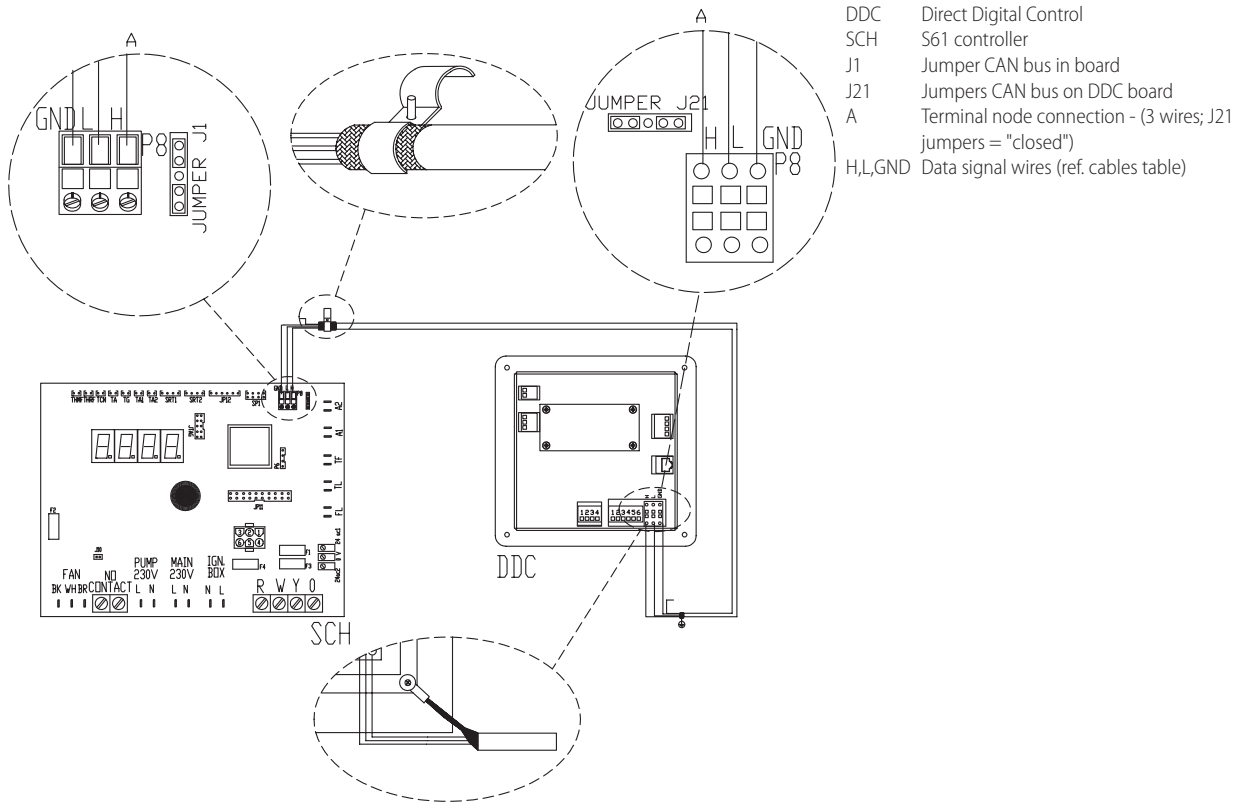

External request

(System (3) see also Paragraph 1.7 p. 16)

It is required to arrange:

- request device (e.g. thermostat, clock, button, ...) fitted with a voltage-free NO contact.



How to connect the external request

Connection of external request is effected on the S61 board located in the electrical panel inside the unit (Figure 4.5 p. 27):

1. Access the electrical board of the appliance according to the Procedure 4.2 p. 24.
2. Connect the voltage-free contact of the external device (Detail CS), through two wires, to **terminals R and W** (respectively: common 24 V AC and heating request) of S61 electronic board.

Figure 4.5 Wiring diagram, external heating enable connection

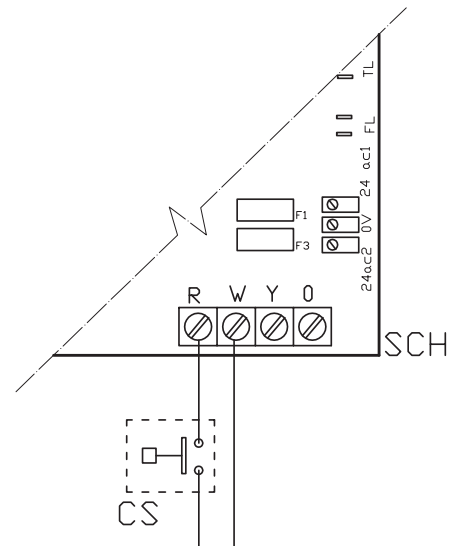

- SCH Electronic board
- R Common
- W Terminal consensus warming

Components NOT SUPPLIED

- CS External request

4.5 WATER CIRCULATION PUMP

4.5.1 Option (1) CONSTANT FLOW circulating pump

It must be mandatorily controlled from the S61 electronic board. The diagram in Figure 4.6 p. 28 is for pumps < 700 W. For

pumps > 700 W it is required to add a control relay and arrange Jumper J10 OPEN.



How to connect the constant flow circulating pump

1. Access the electrical board of the appliance according to

- the Procedure 4.2 p. 24.
2. Connect board S61, to terminals 3-4 of terminal block (MA).
3. Jumper J10 can be opened or closed as described in the note in Figure 4.6 p. 28.

Figure 4.6 Water circulation pump connection - Connection of plant water circulation pumps (power absorption less than 700W), controlled directly by the appliance.

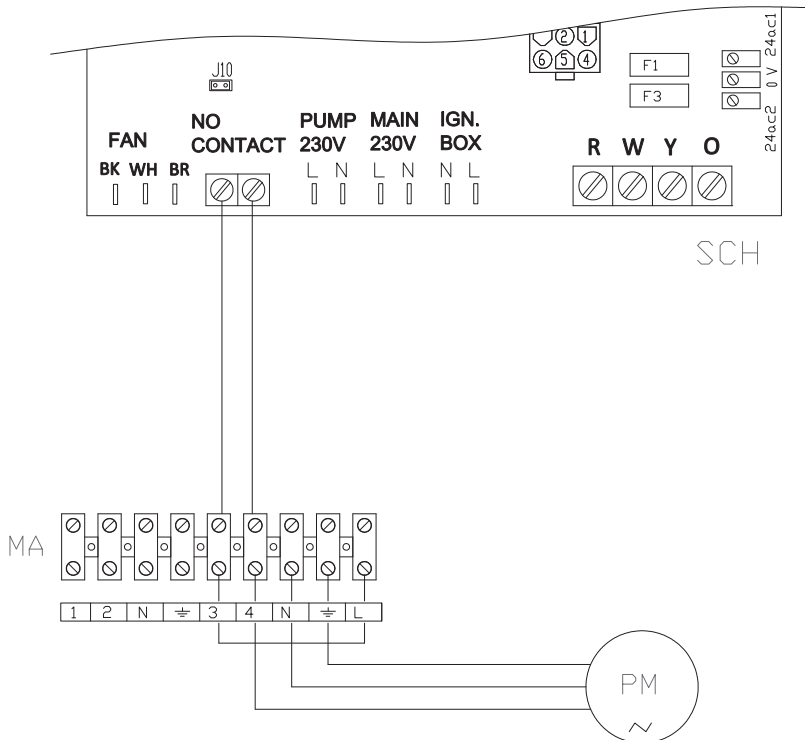

SCH Electronic board
 J10 Jumper (1)
 N.O. CONTACT N.O voltage free contacts
 MA unit terminal block
 L Phase
 N Neutral
 Components NOT SUPPLIED
 PM Water pump < 700 W

Note

- 1 Jumper J10 must be closed if the installed pump is not a Wilo electronic pump.
 Jumper J10 must be opened if the installed pump is a Wilo electronic pump.

4.5.2 Option (2) VARIABLE FLOW circulating pump

It must be mandatorily controlled from the Mod10 electronic board (built into the S61).



How to connect the variable flow circulation pump

The Wilo Stratos Para pump is already standard supplied with the power supply cable and signal cable, both 1.5m long.

For longer distances, use respectively cable FG7 3Gx-1.5mm² m and shielded cable 2x0.75 mm² suitable for 0-10V signal.

To connect the Wilo Stratos Para pump (Figure 4.7 p. 29 or 4.8 p. 29).

1. Connect the brown wire of the pump to terminal "-" HPMP of the Mod10 board, and the white wire of the pump to terminal "+" HPMP of the Mod10 board.
2. Isolate the black wire and the blue one.
3. Protect the pump's supply line with a double pole switch with 2 A delayed fuse (Detail IP, Figure 4.7 p. 29), or connect it directly to the terminals inside the appliance's electrical board (Detail MA, Figure 4.8 p. 29).

Figure 4.7 Wiring diagram for connection of Wilo Stratos Para variable rate pump

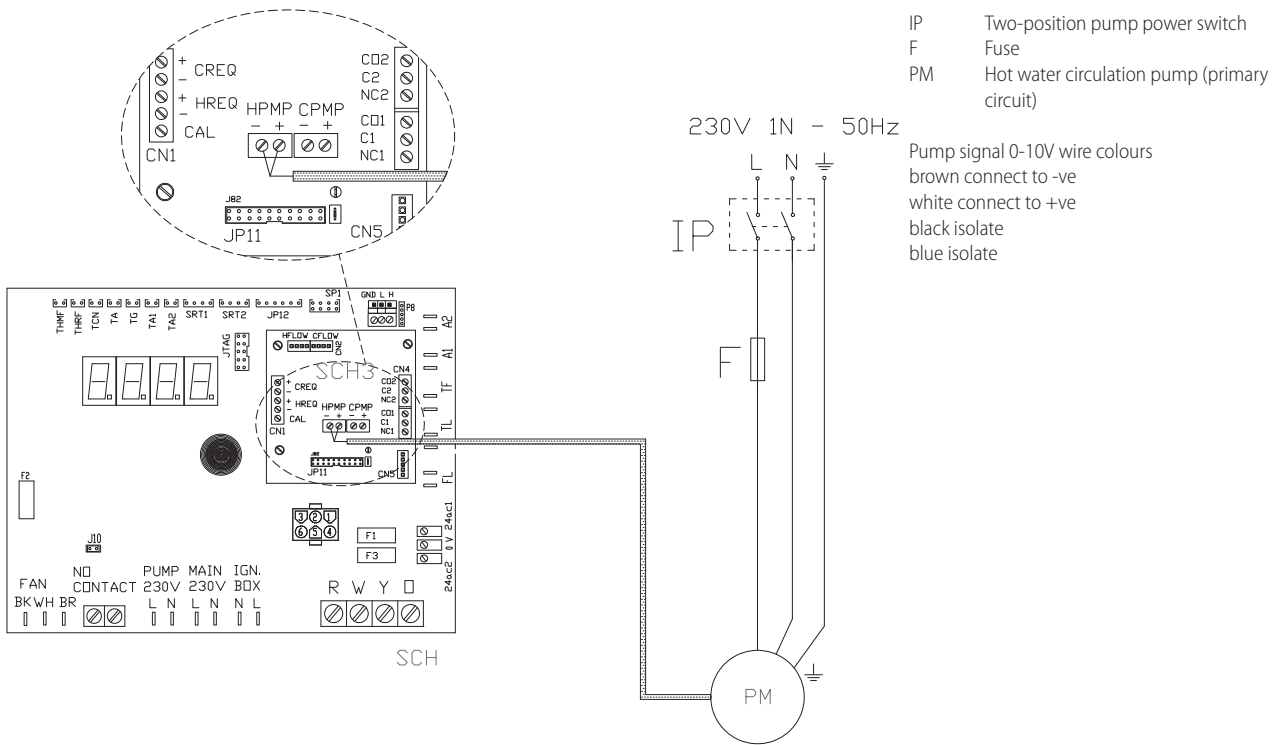
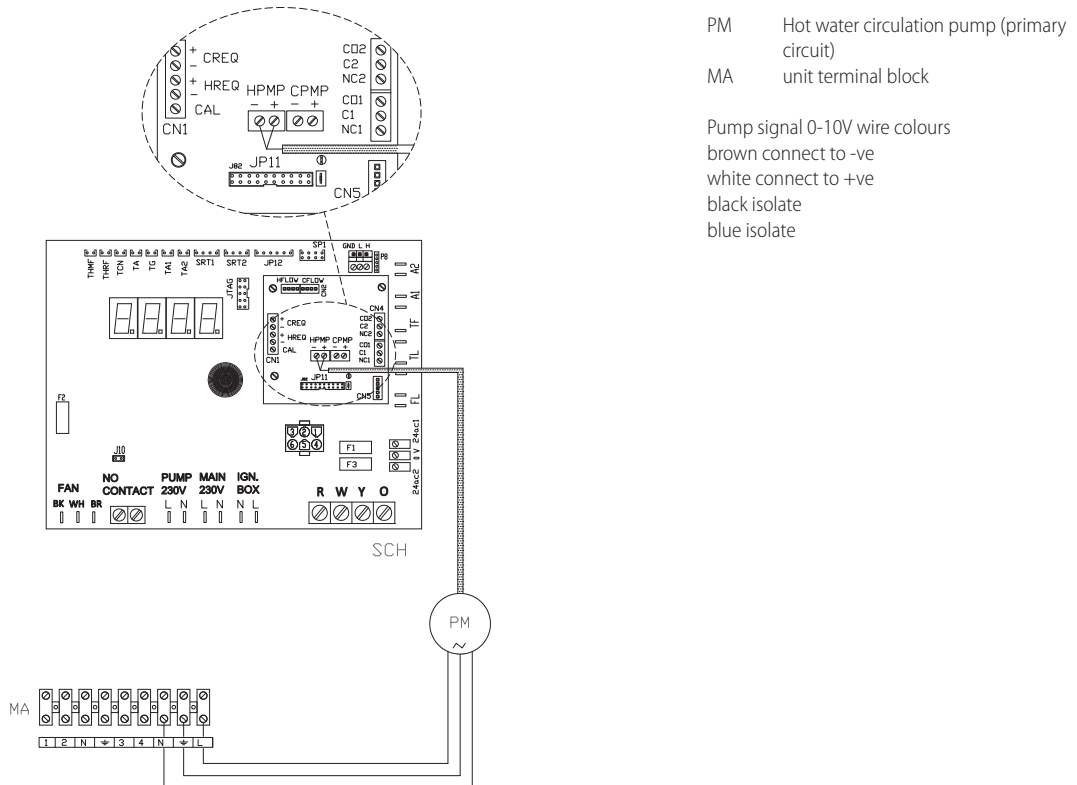



Figure 4.8 Wiring diagram for hooking up the Wilo Stratos Para variable rate pump powered by the unit



5 FIRST START-UP

 First start-up entails checking/setting up the combustion parameters and may exclusively be carried out by a Lochinvar TAC. NEITHER the user NOR the installation

technician is authorised to perform such operations, under penalty of voiding the warranty.

5.1 PRELIMINARY CHECKS

Preliminary checks for first start-up

Upon completing installation, before contacting the TAC the installer must check:

- ▶ Water, electrical and gas systems suitable for the required capacities and equipped with all safety and control devices required by the regulations in force.
- ▶ Absence of leaks in the water and gas systems.
- ▶ Type of gas for which the appliance is designed (natural gas or LPG).
- ▶ Supply gas pressure complying with the values of Table 3.3 p. 22, with max tolerance $\pm 15\%$.
- ▶ Correct operation of the flue exhaust duct.
- ▶ Power supply mains complying with the appliance's rating plate data.
- ▶ Appliance correctly installed, according to the manufacturer's instructions.
- ▶ System installed in a workmanlike manner, according to national and local regulations.

Abnormal or hazardous installation situations

Should any abnormal or hazardous installation situations be found, the TAC shall not perform first start-up and the appliance shall not be commissioned.

These situations may be:

- ▶ Appliance installed inside a room.
- ▶ Failed compliance with minimum clearances.
- ▶ Insufficient distance from combustible or flammable materials.
- ▶ Conditions that do not warrant access and maintenance in safety.
- ▶ Appliance switched on/off with the main switch, instead of the control device provided (DDC, CCP/CCI or external request).
- ▶ Appliance defects or faults caused during transport or installation.
- ▶ Gas smell.
- ▶ Non-compliant mains gas pressure.
- ▶ Non-compliant flue gas exhaust.
- ▶ All situations that may involve operation abnormalities or are potentially hazardous.

Non-compliant system and corrective actions

Should the TAC find any non conformities, the user/installer is bound to perform any corrective procedures required by the TAC.

After performing the remedial actions (the installer's responsibility), if the TAC deems that safety and conformity conditions are in place, first start-up may be effected.

5.2 ELECTRONIC ADJUSTMENT ON THE MACHINE – MENUS AND PARAMETERS OF THE S61 BOARD



Firmware

The instructions on the use of the S61 electronic board concern the **firmware version 3.035**.

The appliance's electronic board (S61)

Figure 5.1 GAHP unit electronic board (S61+Mod10)

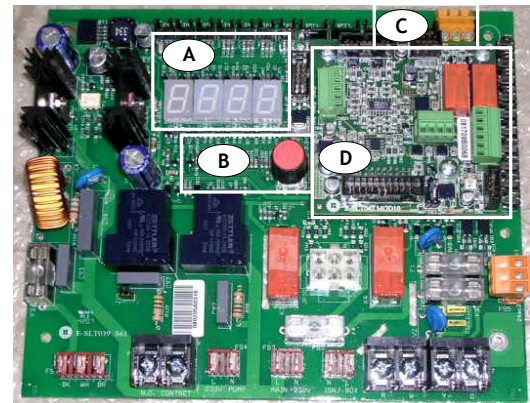

- A 4 digit display
- B Knob
- C CAN port
- D Mod10 controller

Display

The 4-digit display of the S61 board (Detail A Figure 5.1 p. 30) is as follows:

- ▶ The **first digit** (on the left, green) indicates the menu number (e.g. "0.", "1.", "2.", ... "8:").
 - ▶ The **last three digits** (on the right, red) indicate a **code** or a **value** for a parameter, among those included in the selected menu (e.g. "_6" "_20", "161").
- (e.g. menu+parameter "1._6", "2._20", "3.161").

Knob

One of the following actions may be done with the S61 board knob (Detail B in Figure 5.1 p. 30):

- ▶ Enter the menu list (by pressing the first time).
- ▶ Scroll the menu list, or a series of parameters in a menu (by turning).
- ▶ Select a menu or a parameter (by pressing).
- ▶ Modify and confirm the setting of a parameter (turning and pressing).
- ▶ Execute a command (by pressing).
- ▶ Exit a menu and go back to the higher level by selecting the letter "E" which is displayed at the end of the menu list or of a series of parameters in a menu.

The letter "E" is displayed at the end of the menu list or of a series of parameters in a menu, and indicates the exit to go back to the higher level by pressing the knob.

Menus and Parameters

The menus may be display only (functional data or parameters), display and setting (parameters) or control (reset).

Menu for the user (but for the installer and TAC as well)

- ▶ The menu "0.", display only, for functional data detected in real time.
- ▶ The menu "1.", display only, for current values of appliance parameters.
- ▶ Menu "2.", control, to execute flame control unit reset operations, reset errors (Paragraph 7.5 p. 33).
- ▶ Menu "3.", display and setting, to set the value of some system parameters (e.g. water set point temperature); the values are initialised by the TAC at first start-up.

It is accessed without password.

Menu for the installer or TAC (not accessible to the user)

- ▶ Menu "4.", "5.", "6." and "9." are password-protected. These are

specific sections, exclusively intended for qualified personnel (installer or TAC). For information see the Service manual.

- ▶ Menu "7." is display only and intended for the manufacturer.
- ▶ Menu "8." is empty, it may be selected but not used.

Special key for the knob

- To access the menus and parameters of the S61 board, use the special standard supplied key, fastened on the gas pipe above the electrical panel. The key allows the knob to be operated through the suitable hole in the electrical panel cover, operating safely away from live components.
- Always keep the key for future uses.



How to access the menus and parameters

Before Starting:

- (1) Power supply switch on.
- (2) Display of the S61 board showing in sequence the detected water temperature data (if the appliance is in normal operation), or the flashing malfunction and failure codes (if the appliance is in failure).

To access the menus and parameters of the S61 board, proceed as follows (see also Figure 5.1 p. 30):

1. Remove the front panel by removing the fixing screws.
2. Remove the cover of the electrical board to access the S61 board knob.
3. Act on the knob by means of the special key through the suitable hole.
4. Press the knob once to display the menus: the first menu is displayed, "0." (= menu 0).
5. Turn the knob clockwise to scroll down and display the other/subsequent menus; the menu numbers will be displayed in order, "1.", "2.", ... , "6." ... or "E" (= exit).
6. Select the menu of interest (e.g. display "2.___" = menu 2) by pressing the knob; the first parameter code will be displayed, in menu order (e.g. display "2._20" = parameter 20 in menu 2).
7. Turn the knob clockwise to scroll down the other parameters in the menu; the codes will be displayed in order (e.g. display "2._20", "2._21", ... "2._25" = parameters 20, 21, ... 25 in menu 2), or letter "E" (= exit) at the end of the list.
8. Select the parameter of interest (e.g. with code 161 in menu 3) by pressing the knob; the figure previously assigned to the parameter will be displayed, read only or to be set (e.g. the figure "45" for parameter 161 in menu 3 = water temperature set-point at 45 °C); if instead of

a figure/setting it is a command, a flashing code is displayed (e.g. "reS1" for the flame block reset command).

9. Press the knob to reconfirm the figure; or rotate the knob to modify the figure, and press at the end to confirm or set the new figure; if however, it is a matter of controlling an appliance operation, press the knob to execute it.
10. To exit a parameter menu or the menu list and go back to the higher level, turn the knob to display the letter "E" for exit, then press the knob again.
11. Place the cover back on the electrical panel opening and fit the appliance's front panel back on.

5.3 MODIFYING SETTINGS

Modify the settings through the DDC or CCP/CCI

If the appliance is connected to the DDC or to the CCP/CCI control, refer to the relevant manual to modify settings.

How to raise/lower the water temperature setpoint

The water temperature set-point establishes the outlet temperature to the system (water output from the appliance), or inlet from the system (water input in the appliance). The temperature is pre-set by the TAC upon first start-up.



If the appliance is not connected to a DDC or CCP/CCI control, to raise/lower the water temperature set-point with the S61 board, proceed as follows:

1. Access menu 3 under parameter 161 (= water temperature set-point) by rotating and pressing the knob; "3.161" must be displayed (procedure Paragraph 5.2 p. 30).
2. Display the parameter value by pressing the knob; the previously set value is displayed (from 10 to 65 °C); to reconfirm the pre-existing value press the knob again, otherwise go to point 3.
3. Turn the knob to modify the value, increasing or decreasing it, and press it to set the new value.
4. Exit menu 3, and from the menu list, by selecting and pressing letter "E" twice, and go back to the normal display of detected temperature data.

Do not modify complex settings

Specific technical and system knowledge is required for complex settings. Contact a TAC.

6 NORMAL OPERATION



This section is for the end user.

6.1 WARNINGS



General warnings

Prior to using the appliance carefully read the warnings in Chapter III.1 p. 4, providing important information on regulations and on safety.



First start-up by TAC

First start-up may exclusively be carried out by a Lochinvar TAC (Chapter 5 p. 29).



Never power the appliance off while it is running

NEVER power the appliance off while it is running (except in the event of danger, Chapter III.1 p. 4), since the appliance or system might be damaged.

6.2 SWITCH ON AND OFF



Routine switching on/off

The appliance may exclusively be switched on/off by means of the suitably provided control device (DDC, CCP/CCI or external requests).



Do not switch on/off with the power supply switch

Do not switch the appliance on/off with the power supply switch. This may be harmful and dangerous for the appliance and for the system.



Inspections before switching on

Before switching on the appliance, ensure that:

- gas valve open
- appliance electrical power supply (main switch (GS) on)
- DDC or CCP/CCI power supply (if present)
- water circuit ready

How to switch on/off

- ▶ If the appliance is controlled by a DDC or by a CCP/CCI (systems (1) and (2) see Paragraph 1.7 p. 16), refer to the respective manuals.
- ▶ If the appliance is controlled by external request (e.g. thermostat, clock, button, ... with voltage-free NO contact), (system (3) see Paragraph 1.7 p. 16), the appliance is switched on/off by the ON/OFF positions of the external control device.

After switching on with the control, in normal operating

conditions, the appliance starts/stops automatically according to the user's thermal needs, supplying hot water at the programmed temperature.



Although the external request is in the "ON" position, this does not mean the appliance will start immediately, but it will only start when there are actual service demands.

6.3 MODIFYING SETTINGS



Modify the settings through the DDC or CCP/CCI

If the appliance is connected to the DDC or to the CCP/CCI control, refer to the relevant manual to modify settings.



Do not modify complex settings

Specific technical and system knowledge is required for complex settings. Contact a TAC.

6.4 EFFICIENCY

For increased appliance efficiency:

- ▶ Keep the finned coil clean.
- ▶ Adjust the maximum water temperature to the actual system requirements.
- ▶ Reduce repeated switch-ons to the minimum (low loads).
- ▶ Program appliance activation for actual periods of use.
- ▶ Keep water and air filters on plumbing and ventilation systems clean.

7 MAINTENANCE

7.1 WARNINGS



Correct maintenance prevents problems, assures efficiency and keeps running costs low.



Maintenance operations described herein may exclusively be performed by the TAC or skilled maintenance technician.



Any operation on internal components may exclusively be performed by the TAC.



Before performing any operation, switch off the appliance by means of the control device (DDC, CCP/CCI or external request) and wait for the end of the switching off cycle, then disconnect power and gas supply, by acting on the electrical disconnecter and gas valve.



The efficiency checks and every other "check and maintenance operation" (see Tables 7.1 p. 33 and 7.2 p. 33) must be performed with a frequency according to current regulations or, if more restrictive, according to the provisions set forth by the manufacturer, installer or TAC.



Responsibility for efficiency checks, to be carried out for the aims of restricting energy consumption, lies with the system manager.



Environmental or operational heavy conditions

In environmental or operational conditions particularly heavy (for example: heavy-duty use of the appliance, salty environment, etc.), maintenance and cleaning operations must be more frequent.

7.2 PRE-EMPTIVE MAINTENANCE

For pre-emptive maintenance, comply with the recommendations in Table 7.1 p. 33.

Table 7.1

		GAHP A	GAHP GS/WS	AY00-120	GA ACF	GAHP-AR
Guidelines for the preventive maintenance operations						
Check of the unit	visually check of the general condition of the unit and of its finned coil	√ (1)	-	-	√ (1)	√ (1)
	check the correct operation of the device used for monitoring the water flow	√	√	√	√	√
	check the % value of CO ₂	√	√	√	-	-
	check gas pressure to the burners	-	-	-	√	√
	check that the condensate discharge is clean (If necessary, frequency of the maintenance operation must be increased)	√	√	√	-	-
	replace the belts after 6 years or 12,000 hours of operation	√	√	-	√	√
	check/restore the pressure of the primary hydronic circuit	-	-	√	-	-
Check for every DDC or CCI	check that the plant is able to achieve the setpoint temperature	√	√	√	√	√
	download the event history	√	√	√	√	√

(1) It is suggested to clean the finned coil once every 4 years (optimal frequency of the cleaning operation is in any case strongly affected by the installation site). Avoid excessively aggressive cleaning of the finned coil (e.g. high-pressure washer).

7.3 SCHEDULED ROUTINE MAINTENANCE

For scheduled routine maintenance, perform the operations in Table 7.2 p. 33, at least once every 2 years.

Table 7.2

		GAHP A	GAHP GS/WS	AY00-120	GA ACF	GAHP-AR
Ordinary scheduled maintenance						
Check of the unit	clean the combustion chamber	√ (1)	√ (1)	√	√	√ (1)
	clean the burner	√ (1)	√ (1)	√	√	√ (1)
	clean the ignition and flame sensor electrodes	√	√	√	√	√
	check that the condensate discharge is clean	√	√	√	-	-
	replace the silicone gasket between the front plate and the exchanger	-	-	√	-	-

(1) Only in case the analysis of combustion products is non-compliant.

7.4 MESSAGES ON THE DISPLAY

4 digit display

The S61 board of the appliance (Paragraph 1.5 p. 13, Figure 5.1 p. 30) is fitted with a 4-digit display, visible through the sight glass of the front panel.

- ▶ When the appliance is powered on, all the LEDs switch on for 3 sec, then the S61 board name is displayed.
- ▶ After another 15 sec, the appliance is ready to operate.

Signals in normal operation

- ▶ During normal operation, water temperature values alternate on the display: output, input and the difference between the two.

Signals in the event of fault

In the event of fault the display blinks indicating an operational code (first letter on the display: "E" = error, or "U" = warning).

The display rotates after the values of the outlet water temperature, the inlet and the difference between them.

If multiple events are active, they are shown in sequence, ordered by increasing code number.

If warning or error events are active, the left green symbol, shown together with water temperature data, blinks.

If it is a permanent error or warning the appliance stops.

(Table 8.1 p. 34).

7.5 RESTARTING A LOCKED-DOWN UNIT

Fault signals on the display

In the event of locked-down appliance, an operational code flashes on the display (first green figure on the left, letter "U" = warning or "E" = error).

- ▶ To restart the appliance you must know and perform the procedure concerning the issue signalled and identified by the code (Paragraph 8.1 p. 34).
- ▶ Only act if you are familiar with the issue and with the procedure (technical expertise and professional qualifications might be required).
- ▶ If you do not know the code, the problem, or the procedure, or you do not have sufficient skills, and in any case of doubt, contact the TAC.

Locked-down appliance

An external intervention (reset or repair) is required due to an appliance fault or problem with the system.

- ▶ A reset may be enough for a temporary and provisional fault.
- ▶ For a fault or breakdown, alert the maintenance technician or TAC.

Reset

There are two options for resetting a fault:

(1) If the appliance is connected to a DDC or to a CCP/CCI you may act through the control device, as described in the relevant manual.

(2) You may act directly from the S61 board as described below (if the appliance is controlled with external request, this is the only option).



How to perform reset from the S61 board

To perform the reset directly from the S61 board:

1. Access Menu 2 under Parameter "_20", to reset flame block (Error E412), or Parameter "_21", for any other generic reset, turning and pressing the knob; "2._20"/"2._21" must be displayed (procedure Paragraph 5.2 p. 30).
2. Press the knob to display the flashing reset request (e.g. "reS1" to reset flame block).
3. Press the knob again (the second time) to perform the reset; the reset request stops flashing, then "2._XX" is displayed again (e.g. "2._20"). The reset operation has been performed.
4. Exit menu 2 and the menu list, by selecting and pressing letter "E" twice, and go back to the normal display of detected temperature data.

7.6 PERIODS OF INACTIVITY



Avoid emptying the installation

Emptying the system may cause damage due to corrosion of the water pipes.



Deactivate the system in winter

Should you intend to stop the appliance in the winter season, ensure at least one of the following conditions:

1. antifreeze function active (Paragraph 3.5 p. 20)
2. sufficient anti-icing glycol (Paragraph 3.6 p. 21)

Prolonged periods of inactivity

► Should you foresee to leave the appliance inactive for a long period of time, disconnect it from the electrical and gas mains. These operations must be performed by qualified

personnel.



How to deactivate the appliance for long periods of time

1. Switch the appliance off (Paragraph 6.2 p. 32).
2. Only when the appliance is completely off, power it off with the main switch/disconnector switch (Detail GS in Figure 4.2 p. 25).
3. Close the gas valve.
4. If necessary, add water with glycol (if the appliance is disconnected from the power and gas mains, the active anti-icing protection is missing, Paragraph 3.5 p. 20).



How to reactivate the appliance after long periods of inactivity

Before reactivating the appliance, the operator/maintenance technician of the system must first of all:

- Check whether any maintenance operations are required (contact the TAC; see Paragraphs 7.2 p. 32 and 7.3 p. 33).
 - Check content and quality of the water in the system, and if necessary top it up (Paragraphs 3.8 p. 22, 3.7 p. 21 and 3.6 p. 21).
 - Ensure the flue gas exhaust duct is not obstructed, and that the condensate drain is clean.
- After completing the above checks:

1. Open the gas valve and ensure there are no leaks; should gas smell be noticed, close the gas valve again, do not switch any electrical devices on and request intervention by qualified personnel.
2. Power on with the main power supply switch (GS, Figure 4.2 p. 25).
3. Switch on the appliance by means of the provided control device (DDC, CCP/CCI or external request, Paragraph 4.4 p. 26).

8 DIAGNOSTICS

8.1 OPERATIVE CODES

Table 8.1 Operative codes GAHP A

CODES	DESCRIPTION	Warning (u)	Error (E)
400	Flame controller reset circuit fault	NA	Power cycle the appliance. If the code persists, shows up again or in case of doubt, contact the TAC.
401	Limit thermostat trip	Contact the TAC.	
402	Flue gas thermostat trip	Contact the TAC.	
405	Outdoor temperature exceeding operational limits	NA	Reset is automatic when the triggering condition ceases.
406	Outdoor temperature below operational limits	Non-blocking Warning (informative code). Reset is automatic when the triggering condition ceases.	NA
407	High generator temperature	Reset is automatic when the triggering condition ceases.	Reset may be performed from the DDC/CCI or from the S61 board (menu 2, parameter 21). If the code persists, shows up again or in case of doubt, contact the TAC.
408	Flame controller error	NA	Contact authorised Technical Assistance
410	Low hot water flow	Reset is automatic when the triggering condition ceases.	Check and clean water filters on the system. Check for air in the system. Check water flow pump. Power cycle the appliance. Reset may be performed from the DDC/CCI or from the S61 board (menu 2, parameter 21). If the code persists, shows up again or in case of doubt, contact the TAC.

CODES	DESCRIPTION	Warning (u)	Error (E)
411	Insufficient rotation of oil pump	Reset occurs automatically 20 minutes after the code is generated.	Reset may be performed from the DDC/CCI or from the S61 board (menu 2, parameter 21). If the code persists, shows up again or in case of doubt, contact the TAC.
412	Flame controller lockout	Reset is automatic up to 4 attempts (in about 5 minutes).	Check gas supply. Reset may be performed from the DDC/CCI or from the S61 board (menu 2, parameter 20). If the code persists or in case of doubt, contact the TAC.
416	Hot water delivery temperature probe fault	NA	Reset may be performed from the DDC/CCI or from the S61 board (menu 2, parameter 21). If the code persists, shows up again or in case of doubt, contact the TAC.
417	Hot water inlet temperature probe fault	NA	Reset may be performed from the DDC/CCI or from the S61 board (menu 2, parameter 21). If the code persists, shows up again or in case of doubt, contact the TAC.
420	Generator temperature probe fault	NA	Reset may be performed from the DDC/CCI or from the S61 board (menu 2, parameter 21). If the code persists, shows up again or in case of doubt, contact the TAC.
422	Water flowmeter fault	NA	Reset may be performed from the DDC/CCI or from the S61 board (menu 2, parameter 21). If the code persists, shows up again or in case of doubt, contact the TAC.
423	Air-gas mix temperature probe fault	NA	Reset may be performed from the DDC/CCI or from the S61 board (menu 2, parameter 21). If the code persists, shows up again or in case of doubt, contact the TAC.
424	Flue gas temperature probe fault	Reset is automatic when the triggering condition ceases.	Reset may be performed from the DDC/CCI or from the S61 board (menu 2, parameter 21). If the code persists, shows up again or in case of doubt, contact the TAC.
425	Clogged condensate drain	NA	Check and clean condensate discharge. Reset may be performed from the DDC/CCI or from the S61 board (menu 2, parameter 21). If the code persists, shows up again or in case of doubt, contact the TAC.
426	Generator fins temperature probe fault	Reset is automatic when the triggering condition ceases.	Reset may be performed from the DDC/CCI or from the S61 board (menu 2, parameter 21). If the code persists, shows up again or in case of doubt, contact the TAC.
428	Flame controller error	NA	Power off the appliance. Contact the TAC.
429	Gas solenoid valve without electrical power	Reset occurs automatically if the gas solenoid valve switches on again within 10 minutes (with central flame control unit on).	Reset may be performed from the DDC/CCI or from the S61 board (menu 2, parameter 21). If the code persists, shows up again or in case of doubt, contact the TAC.
430	High flue gas or generator fins temperature	Reset is automatic when the triggering condition ceases.	Reset may be performed from the DDC/CCI or from the S61 board (menu 2, parameter 21). If the code persists, shows up again or in case of doubt, contact the TAC.
431	Hot water temperature exceeding operational limits	Check configuration of other heat generators on the system. Check water flow. Check system thermal load. Reset is automatic when the triggering condition ceases.	NA
434	-	Contact the TAC.	NA
436	Blower fault	Reset occurs automatically 20 minutes after the code is generated.	Reset may be performed from the DDC/CCI or from the S61 board (menu 2, parameter 21). If the code persists, shows up again or in case of doubt, contact the TAC.
437	Low air-gas mix temperature	Non-blocking Warning (informative code). The code is reset automatically when the triggering condition ceases.	NA
444	Evaporator temperature probe fault	NA	Reset may be performed from the DDC/CCI or from the S61 board (menu 2, parameter 21). If the code persists, shows up again or in case of doubt, contact the TAC.
446	High hot water inlet temperature	Check configuration of other heat generators on the system. Reset is automatic and occurs if the generating condition ceases with circulating pump on or 20 minutes after the code is generated with circulating pump off.	NA
447	Hot water inlet temperature below operational limits	Reset occurs automatically when the generating cause resolves or 430 seconds after the code is generated.	Reset occurs automatically when the condition that generated the code ceases. If the code shows up again or in case of doubt contact the TAC.
448	High hot water differential temperature	Check water flow. Reset occurs automatically 20 minutes after the code is generated.	Reset occurs automatically when the condition that generated the code ceases. If the code shows up again or in case of doubt contact the TAC.

CODES	DESCRIPTION	Warning (u)	Error (E)
449	Missing auxiliary board	NA	Contact the TAC.
452	Defrosting cycle activated	Non-blocking Warning (informative code). The code clears automatically when execution of defrosting ends.	NA
453	Water flow while system in cooling mode	Reset is automatic when the triggering condition ceases.	NA
460	Defrosting valve has failed to open	Non-blocking Warning (informative code). Reset is automatic, however, it is advisable to contact the TAC.	Reset may be performed from the DDC/CCI or from the S61 board (menu 2, parameter 21). If the code persists, shows up again or in case of doubt, contact the TAC.
461	Oil pump priming cycle activated	The priming cycle lasts 30' if activated manually or 10 minutes if activated automatically. Reset is automatic when the triggering condition ceases.	NA
478	High hot water delivery temperature	Reset is automatic when the triggering condition ceases.	NA
479	Heating antifreeze function activated	Non-blocking Warning (informative code). The code clears automatically when antifreeze function execution ends.	NA
80/480	Incomplete functional parameters	Contact the TAC.	
481	Invalid bank 1 parameters	Reset is automatic when the triggering condition ceases.	Contact the TAC.
482	Invalid bank 2 parameters	Reset is automatic when the triggering condition ceases.	Contact the TAC.
484	Transformer or 24 Vac fuse fault	NA	Contact the TAC.
485	Invalid module type configuration parameters	NA	Contact the TAC.
486	ROM board fault	NA	Contact the TAC.
487	pRAM board fault	NA	Contact the TAC.
488	xRAM board fault	NA	Contact the TAC.
489	Registers board fault	NA	Contact the TAC.
490	Outdoor temperature probe fault	NA	Reset may be performed from the DDC/CCI or from the S61 board (menu 2, parameter 21). If the code persists, shows up again or in case of doubt, contact the TAC.
491	Electronic board fault	NA	Contact the TAC.

NA: Not Applicable

APPENDICES

PRODUCT FICHE

Figure

Table 8
COMMISSION DELEGATED REGULATION (EU) No 811/2013

Technical parameters for heat pump space heaters and heat pump combination heaters

Model(s):	GAHP A HT						
Air-to-water heat pump:	yes						
Water-to-water heat pump:	no						
Brine-to-water heat pump:	no						
Low-temperature heat pump:	no						
Equipped with a supplementary heater:	no						
Heat pump combination heater:	no						
Parameters shall be declared for medium-temperature application.							
Parameters shall be declared for average, colder and warmer climate conditions.							
Item	Symbol	Value	Unit	Item	Symbol	Value	Unit
AVERAGE CLIMATE CONDITIONS							
Rated heat output (*)	<i>Prated</i>	29,6	kW	Seasonal space heating energy efficiency	η_s	111	%
Declared capacity for heating for part load at indoor temperature 20 °C and outdoor temperature Tj				Declared coefficient of performance or primary energy ratio for part load at indoor temperature 20 °C and outdoor temperature Tj			
Tj = -7 °C	<i>Pdh</i>	26,1	kW	Tj = -7 °C	<i>PERd</i>	96	%
Tj = +2 °C	<i>Pdh</i>	16,0	kW	Tj = +2 °C	<i>PERd</i>	120	%
Tj = +7 °C	<i>Pdh</i>	10,4	kW	Tj = +7 °C	<i>PERd</i>	117	%
Tj = +12 °C	<i>Pdh</i>	4,4	kW	Tj = +12 °C	<i>PERd</i>	111	%
Tj = bivalent temperature	<i>Pdh</i>	-	kW	Tj = bivalent temperature	<i>PERd</i>	-	%
Annual energy consumption	<i>Q_{HE}</i>	198	GJ				
COLDER CLIMATE CONDITIONS							
Rated heat output (*)	<i>Prated</i>	29,4	kW	Seasonal space heating energy efficiency	η_s	107	%
Declared capacity for heating for part load at indoor temperature 20 °C and outdoor temperature Tj				Declared coefficient of performance or primary energy ratio for part load at indoor temperature 20 °C and outdoor temperature Tj			
Tj = -7 °C	<i>Pdh</i>	17,9	kW	Tj = -7 °C	<i>PERd</i>	109	%
Tj = +2 °C	<i>Pdh</i>	10,9	kW	Tj = +2 °C	<i>PERd</i>	117	%
Tj = +7 °C	<i>Pdh</i>	7,1	kW	Tj = +7 °C	<i>PERd</i>	112	%
Tj = +12 °C	<i>Pdh</i>	3,2	kW	Tj = +12 °C	<i>PERd</i>	111	%
Tj = bivalent temperature	<i>Pdh</i>	-	kW	Tj = bivalent temperature	<i>PERd</i>	-	%
Tj = operation limit temperature	<i>Pdh</i>	29,4	kW	Tj = operation limit temperature	<i>PERd</i>	87	%
For air-to-water heat pumps: Tj = -15 °C (if TOL < -20 °C)	<i>Pdh</i>	24,1	kW	For air-to-water heat pumps: Tj = -15 °C (if TOL < -20 °C)	<i>PERd</i>	90	%
Annual energy consumption	<i>Q_{HE}</i>	244	GJ				
WARMER CLIMATE CONDITIONS							
Rated heat output (*)	<i>Prated</i>	36,4	kW	Seasonal space heating energy efficiency	η_s	116	%
Declared capacity for heating for part load at indoor temperature 20 °C and outdoor temperature Tj				Declared coefficient of performance or primary energy ratio for part load at indoor temperature 20 °C and outdoor temperature Tj			
Tj = +2 °C	<i>Pdh</i>	36,4	kW	Tj = +2 °C	<i>PERd</i>	119	%
Tj = +7 °C	<i>Pdh</i>	23,3	kW	Tj = +7 °C	<i>PERd</i>	122	%
Tj = +12 °C	<i>Pdh</i>	10,6	kW	Tj = +12 °C	<i>PERd</i>	116	%
Tj = bivalent temperature	<i>Pdh</i>	-	kW	Tj = bivalent temperature	<i>PERd</i>	-	%
Annual energy consumption	<i>Q_{HE}</i>	151	GJ				

Figure

Bivalent temperature	T_{biv}	TOL < $T_{designh}$	°C	For air-to-water heat pumps: Operation limit temperature	TOL	-22	°C
				Heating water operating limit temperature	$WTOL$	65	°C
Power consumption in modes other than active mode				Supplementary heater			
Off mode	P_{OFF}	0,000	kW	Rated heat output	P_{sup}	-	kW
Thermostat-off mode	P_{TO}	0,021	kW	Type of energy input	monovalent		
Standby mode	P_{SB}	0,005	kW				
Crankcase heater mode	P_{CK}	-	kW				
Other items							
Capacity control		variable		For air-to-water heat pumps: Rated air flow rate, outdoors	—	11000	m ³ /h
Sound power level, indoors/ outdoors	L_{WA}	- / 80	dB	For water- or brine-to-water heat pumps: Rated brine or water flow rate, outdoor heat exchanger	—	-	m ³ /h

(*) For heat pump space heaters and heat pump combination heaters, the rated heat output P_{rated} is equal to the design load for heating $P_{designh}$, and the rated heat output of a supplementary heater P_{sup} is equal to the supplementary capacity for heating $sup(T_j)$.

Additional information required by COMMISSION REGULATION (EU) No 813/2013, Table 2:

Emissions of nitrogen oxides:	NO_x	40	mg/ kWh
-------------------------------	--------	----	------------

Figure

Table 8
COMMISSION DELEGATED REGULATION (EU) No 811/2013

Technical parameters for heat pump space heaters and heat pump combination heaters

Model(s):	GAHP A HT S1						
Air-to-water heat pump:	yes						
Water-to-water heat pump:	no						
Brine-to-water heat pump:	no						
Low-temperature heat pump:	no						
Equipped with a supplementary heater:	no						
Heat pump combination heater:	no						
Parameters shall be declared for medium-temperature application.							
Parameters shall be declared for average, colder and warmer climate conditions.							
Item	Symbol	Value	Unit	Item	Symbol	Value	Unit
AVERAGE CLIMATE CONDITIONS							
Rated heat output (*)	<i>Prated</i>	29,6	kW	Seasonal space heating energy efficiency	η_s	113	%
Declared capacity for heating for part load at indoor temperature 20 °C and outdoor temperature Tj				Declared coefficient of performance or primary energy ratio for part load at indoor temperature 20 °C and outdoor temperature Tj			
Tj = -7 °C	<i>Pdh</i>	26,1	kW	Tj = -7 °C	<i>PERd</i>	97	%
Tj = +2 °C	<i>Pdh</i>	16,0	kW	Tj = +2 °C	<i>PERd</i>	122	%
Tj = +7 °C	<i>Pdh</i>	10,4	kW	Tj = +7 °C	<i>PERd</i>	119	%
Tj = +12 °C	<i>Pdh</i>	4,4	kW	Tj = +12 °C	<i>PERd</i>	113	%
Tj = bivalent temperature	<i>Pdh</i>	-	kW	Tj = bivalent temperature	<i>PERd</i>	-	%
Annual energy consumption	<i>Q_{HE}</i>	195	GJ				
COLDER CLIMATE CONDITIONS							
Rated heat output (*)	<i>Prated</i>	29,4	kW	Seasonal space heating energy efficiency	η_s	109	%
Declared capacity for heating for part load at indoor temperature 20 °C and outdoor temperature Tj				Declared coefficient of performance or primary energy ratio for part load at indoor temperature 20 °C and outdoor temperature Tj			
Tj = -7 °C	<i>Pdh</i>	17,9	kW	Tj = -7 °C	<i>PERd</i>	110	%
Tj = +2 °C	<i>Pdh</i>	10,9	kW	Tj = +2 °C	<i>PERd</i>	119	%
Tj = +7 °C	<i>Pdh</i>	7,1	kW	Tj = +7 °C	<i>PERd</i>	114	%
Tj = +12 °C	<i>Pdh</i>	3,2	kW	Tj = +12 °C	<i>PERd</i>	113	%
Tj = bivalent temperature	<i>Pdh</i>	-	kW	Tj = bivalent temperature	<i>PERd</i>	-	%
Tj = operation limit temperature	<i>Pdh</i>	29,4	kW	Tj = operation limit temperature	<i>PERd</i>	88	%
For air-to-water heat pumps: Tj = -15 °C (if TOL < -20 °C)	<i>Pdh</i>	24,1	kW	For air-to-water heat pumps: Tj = -15 °C (if TOL < -20 °C)	<i>PERd</i>	91	%
Annual energy consumption	<i>Q_{HE}</i>	239	GJ				
WARMER CLIMATE CONDITIONS							
Rated heat output (*)	<i>Prated</i>	36,4	kW	Seasonal space heating energy efficiency	η_s	117	%
Declared capacity for heating for part load at indoor temperature 20 °C and outdoor temperature Tj				Declared coefficient of performance or primary energy ratio for part load at indoor temperature 20 °C and outdoor temperature Tj			
Tj = +2 °C	<i>Pdh</i>	36,4	kW	Tj = +2 °C	<i>PERd</i>	120	%
Tj = +7 °C	<i>Pdh</i>	23,3	kW	Tj = +7 °C	<i>PERd</i>	123	%
Tj = +12 °C	<i>Pdh</i>	10,6	kW	Tj = +12 °C	<i>PERd</i>	118	%
Tj = bivalent temperature	<i>Pdh</i>	-	kW	Tj = bivalent temperature	<i>PERd</i>	-	%
Annual energy consumption	<i>Q_{HE}</i>	150	GJ				

Figure

Bivalent temperature	T_{biv}	TOL < $T_{designh}$	°C	For air-to-water heat pumps: Operation limit temperature	TOL	-22	°C
				Heating water operating limit temperature	$WTOL$	65	°C
Power consumption in modes other than active mode				Supplementary heater			
Off mode	P_{OFF}	0,000	kW	Rated heat output	P_{sup}	-	kW
Thermostat-off mode	P_{TO}	0,021	kW	Type of energy input	monovalent		
Standby mode	P_{SB}	0,005	kW				
Crankcase heater mode	P_{CK}	-	kW				
Other items				For air-to-water heat pumps:			
Capacity control	variable			Rated air flow rate, outdoors	—	11000	m ³ /h
Sound power level, indoors/ outdoors	L_{WA}	- / 74	dB	For water- or brine-to-water heat pumps: Rated brine or water flow rate, outdoor heat exchanger	—	-	m ³ /h

(*) For heat pump space heaters and heat pump combination heaters, the rated heat output P_{rated} is equal to the design load for heating $P_{designh}$, and the rated heat output of a supplementary heater P_{sup} is equal to the supplementary capacity for heating $sup(T_j)$.

Additional information required by COMMISSION REGULATION (EU) No 813/2013, Table 2:

Emissions of nitrogen oxides:	NO_x	40	mg/ kWh
-------------------------------	--------	----	------------



Lochinvar Ltd
High Efficiency Water Heaters and Boilers
7 Lombard Way, The MXL Centre,
Banbury, Oxon OX16 4TJ
T +44 (0) 1295 269981
F +44 (0) 1295 271640
sales@lochinvar.ltd.uk
www.lochinvar.ltd.uk