

# Knight Low NOx Gas Fired Single Flue Water Heater with Pilot Ignition

Installation, Commissioning,  
User & Maintenance Instructions

Models:  
LGL 75 G CE and PG CE  
LGL 85 G CE and PG CE

LV313130 | October 2018





## **IMPORTANT INFORMATION**

These instructions must be read and understood before installing, commissioning, operating or maintaining the equipment.

---

# Preface

## Copyright

Copyright © 2018 Lochinvar Ltd.

All rights reserved.

Nothing from this publication may be copied, reproduced and/or published by means of printing, photocopying or by whatsoever means, without the prior written approval of Lochinvar Ltd..

Lochinvar Ltd. reserves the right to modify specifications in this manual.

## Trademarks

Brand names in this manual are registered trademarks of their respective owners.

## Warranty

Refer to the appendix [Warranty](#) (see 12.6) for the warranty provisions.

## Liability

### User

Lochinvar accepts no liability when the water heater is not used correctly and requires the user to:

- Read this manual carefully and obey the instructions.
- Ask your installation engineer for advise about the use of the water heater.
- Make sure that the service and maintenance activities are done by a qualified engineer.

### Installation engineer

Lochinvar accepts no liability when the water heater is not used correctly and requires the installation engineer to:

- Read this manual carefully and obey the instructions.
- Make sure that the entire water heater installation complies with the applicable [regulations](#) (see 6).
- Make sure that the water heater is tested before the installation is taken into use.
- Explain the correct use to the user.

- Notify the user when service and maintenance activities are necessary.
- Make sure that you hand over all applicable manuals.

## Supplier

The LGL water heater is designed in accordance with the applicable regulations. The water heater is delivered with the CE-marking and all necessary documentation to obey these regulations.

Lochinvar accepts no liability for claims from third parties when:

- The instructions for the correct installation of the water heater are not obeyed.
- The instructions for the correct use of the water heater are not obeyed.
- The water heater did not have maintenance on the correct maintenance interval.

For more information, refer to the General Terms of Sales. These are available on request, free of charge.

We believe that this manual provides you with accurate and complete descriptions of all relevant components. If you, nonetheless find errors or inaccuracies in this manual, please inform Lochinvar. This helps us to further improve our documentation.

## Compliance

To safely produce domestic hot water, the design and construction of the LGL water heaters is in accordance with:

- the European Regulations 2016/426 on appliances burning gaseous fuels (GAR).
- the European Standard for Gas-fired storage water heaters for the production of domestic hot water (EN89).
- The European ECO-Design Directive.
- The European Energy Labeling Directive

Refer to the appendix [Declaration of conformity](#) (see 12.5).

## Regulations

It is law that all gas appliances are installed by competent persons, in accordance with The Gas Safety (Installation and Use) Regulations 1998. Failure to install appliances correctly could lead to prosecution. It is in your own interest, and that of safety, to ensure that this law is complied with. The installation of the equipment MUST be

in accordance with the relevant requirements of the Gas Safety Regulations, Building Regulations, I.E.E. Regulations and the bylaws of the local water undertaking.

In addition, the installation should follow the relevant guidance offered in the following documents. It is not practical to list all relevant information due to continuous changes but emphasis is placed on the following documents, as failure to comply with the guidance given will almost certainly result in an unsatisfactory installation:

- British Standards (BS)
- Institute of Gas Engineers and Managers (IGEM) Publications
- CIBSE Guides
- Clean Air Act
- H.S.E Guidance



### Note

Manufacturer's notes must not be taken in any way as overriding statutory obligations.

## Contact information

In the event of problems with your gas, electricity or water supply connections or when you have any comments or questions, please contact your supplier.

## About this manual

### Scope

This manual gives information about safe and correct use of the water heater and how installation, maintenance and service activities have to be done correctly. You must obey the instructions in this manual.



### Caution

Read this manual carefully before you start the water heater. It can cause personal injury and damage to the water heater when you do not read the manual and/or do not obey the instructions.

The purpose of this manual is to:

- describe the working principles and layout of the water heater
- explain the safety devices
- highlight possible hazards
- describe the use of the water heater
- describe the installation, service and maintenance of the water heater

This manual has two parts:

- An User part that describes the correct usage of the water heater.
- An Installation, Maintenance and Service part, that describes the correct installation and maintenance procedures.

## Target group

The information in this manual applies to three target groups:

- users
- installation engineers
- service and maintenance engineers

The User part is intended for the (end) users. The Installation, Maintenance and Service part is intended for the installation engineers and the service and maintenance engineers.

## Notation conventions

This manual uses the following text conventions:

- Numbers between parentheses e.g. (1), refer to elements in a figure that are described by the text.
- Knobs or symbols on the knobs are always shown between brackets, for example: [★], [🔥], [●].
- Cross-references to sections, tables, figures etc. are underlined and written as (see "..."). In the digital version, the cross-references function as hyperlinks that can be used to navigate through the manual by clicking on them. Example: Safety (see 2).

This manual contains the following text styles/symbols for situations that may endanger users/engineers, cause damage to equipment or need special attention:



### Note

A note gives more information on a topic.



### Caution

Obey the caution instructions to prevent damage of the water heater.



### Warning

Obey the warning instructions to prevent danger of personal injury, and serious damage to the water heater.

**Danger**

Obey the danger instructions to prevent danger of serious personal injuries or death, and serious damage to the water heater.

**Document identification**

Article number	Language	Version
0313130	EN	1.0

**Table of Contents**

	<b>Preface.....3</b>
	Copyright..... 3
	Trademarks..... 3
	Warranty.....3
	Liability.....3
	Compliance..... 3
	Regulations..... 3
	Contact information..... 4
	<b>About this manual..... 4</b>
	Scope..... 4
	Target group.....4
	Notation conventions..... 4
	Document identification..... 5
	<b>User part..... 6</b>
<b>1</b>	<b>Introduction..... 6</b>
<b>2</b>	<b>Safety..... 6</b>
<b>3</b>	<b>Operation..... 7</b>
3.1	Control components..... 7
3.1.1	Operation control knob.....7
3.1.2	Temperature control knob.....8
3.2	Status of the water heater.....8
3.2.1	Operating modes.....8
<b>4</b>	<b>Use.....8</b>
4.1	Turn on the water heater.....8
4.1.1	Temperature setting..... 9
4.2	Turn off the water heater.....9
4.2.1	Turn off for a short period.....9
4.2.2	Turn off for a long period.....9
	<b>Installation, Maintenance and Service part.....9</b>
<b>5</b>	<b>Introduction.....9</b>
5.1	About the water heater..... 9
5.2	Working principle..... 9
<b>6</b>	<b>Safety..... 10</b>
6.1	Safety instructions.....10
6.2	Instructions on the water heater.....10
6.3	Safety devices..... 11
6.4	Environmental aspects..... 11
6.4.1	Recycling.....11
6.4.2	Disposal.....11
<b>7</b>	<b>Water heater..... 12</b>
7.1	Structure of the water heater..... 12
<b>8</b>	<b>Installation..... 12</b>
8.1	Packaging.....12
8.2	Conditions..... 12
8.2.1	Ambient conditions..... 12
8.2.2	Maximum floor load..... 12
8.2.3	Water composition..... 13
8.2.4	Working clearances..... 13
8.2.5	Placement of the water heater.....13
8.3	Installation diagram..... 13
8.4	Water connections..... 14
8.4.1	Cold water connection..... 14
8.4.2	Hot water connection..... 14
8.4.3	Circulation connection..... 14
8.4.4	Drain valve..... 14
8.5	Gas connection..... 14
8.6	Flue gas discharge..... 15
8.6.1	Draught diverter.....15
8.6.2	T.R.S. (Thermal Reflux Safeguard)..... 15
8.6.3	Discharge pipe..... 15
8.7	Commissioning.....15
8.7.1	Filling..... 15
8.7.2	Burner pressure..... 16
8.7.3	Turn on the water heater..... 16
8.8	Decommissioning..... 16
8.8.1	Turn off the water heater..... 16
8.8.2	Draining..... 16
<b>9</b>	<b>Conversion of gas type..... 16</b>
<b>10</b>	<b>Maintenance..... 17</b>
10.1	Performance check..... 17
10.2	Water-side maintenance..... 17
10.2.1	Inspect the anode.....17
10.2.2	Inspect the inlet security group..... 18
10.2.3	Descale the tank..... 18
10.3	Gas-side maintenance..... 18
10.3.1	Clean the burners..... 19
10.3.2	Clean the combustion chamber.....19
10.3.3	Assemble the burners..... 19
10.3.4	Finalization..... 19
<b>11</b>	<b>Troubleshooting..... 20</b>
11.1	General.....20
11.1.1	Safety thermostat..... 20
11.1.2	T.R.S. (Thermal Reflux Safeguard)..... 20

11.1.3	Condensation.....	20
11.2	General errors.....	21
<b>12</b>	<b>Appendices.....</b>	<b>22</b>
12.1	Technical details.....	22
12.2	Dimensions.....	23
12.3	EcoDesign details.....	25
12.4	Gas details.....	25
12.5	Declaration of conformity.....	28
12.6	Warranty.....	29

Fig. LGL water heater

## 1 Introduction

The LGL water heater stores and heats water for sanitary purposes.

Cold water enters the tank (3) through the water inlet (2). The heated water leaves the tank at the top through the hot water outlet (1). When hot water is used, the tank of the water heater is filled with the same amount of cold water.

To operate the water heater, the control knobs on the gas control valve (5) are used.

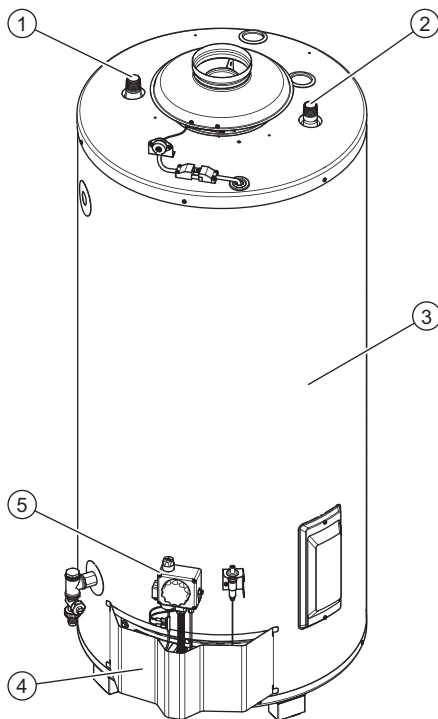

1. Water outlet
2. Water inlet
3. Tank
4. Outer door
5. Gas control valve

## 2 Safety

Lochinvar cannot be held responsible for damages or injuries which can be lead back to:

- Failure to follow the instructions provided in this manual.
- Carelessness during use or maintenance of the water heater.

Every user must study the user part of this manual and must follow the instructions in this part of the manual strictly. Do not change the sequence of the described actions. This manual must be available for the user and service engineer at all times.



### Warning

If you smell gas:

- Shut off the mains gas supply valve!
- Avoid causing sparks! Do not use any electrical equipment or switch, i.e. no telephones, plugs or bells!
- No naked flames! No smoking!
- Open windows and doors!
- Warn occupants and leave the building!
- After leaving the building, alert the gas distribution company or your installation engineer.



#### Caution

Do not store or use chemical substances in the room where the water heater is installed because of the risk of explosion and corrosion of the water heater. Some propellants, bleaching agents and degreasing agents etc. disperse of explosive vapors and/or cause accelerated corrosion. If the water heater is used in a room where such substances are stored or used, the warranty will be void.

#### Caution

Installation, maintenance and service may only be carried out by a qualified engineer.

#### Caution

The water heater is not intended for use by persons with reduced physical, sensory or mental capacities, or who lack the necessary experience or knowledge. When the person responsible for their safety is supervising or has explained how the water heater should be used, these persons can use the water heater.

#### Caution

This water heater is not intended to be used by children. Always supervise children, and make sure that they do not play with the water heater.



#### Note

Regular maintenance extends the service life of the water heater. To determine the correct service interval, the service and maintenance engineer must do a check on both the water and gas side of the water heater three months after installation. Based on this check, the best service interval can be determined.

## 3 Operation

### 3.1 Control components

For the use of the LGL water heater, the gas control valve has two control knobs:

- The operation control knob on top of the gas control valve (see 3.1.1).
- The temperature control knob on the front of the gas control valve (see 3.1.2).

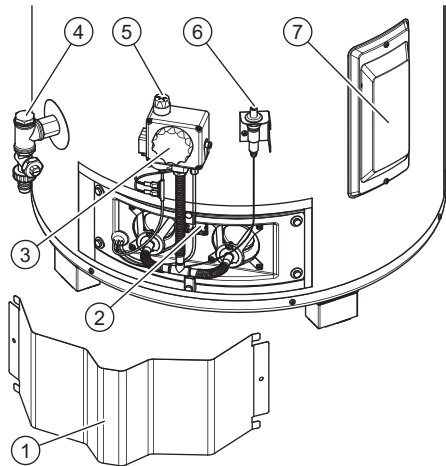

Fig. Control components



1. Outer door
2. Pilot flame inspection window
3. Temperature control knob
4. Drain valve
5. Operation control knob
6. Piezo igniter
7. Cleaning opening

#### 3.1.1 Operation control knob

You can use the operation control knob to activate and to deactivate the water heater. The symbols on the operation control knob indicate the 3 possible settings.

Symbol	Explanation
	Water heater is activated, the pilot flame burns (frost protection). In this setting, you can put the water heater in the <b>OFF mode</b> or in the <b>ON mode</b> with the temperature control knob.
	In this setting, you can ignite the pilot flame to turn on the water heater (no frost protection).
	Water heater is <b>OFF</b> , pilot flame does not burn (no frost protection).

### 3.1.2 Temperature control knob

With the temperature control knob you can set the desired water temperature of the water heater (see 4.1.1).

When the operation control knob is in the position [, you can use the temperature control knob to set the water heater in the **OFF mode** or in the **ON mode**:

- Turn the temperature control knob anticlockwise to ignite the main burners (**ON mode**).
- Turn the temperature control knob clockwise to shutdown the main burners. Only the pilot flame burns (**OFF mode**).

## 3.2 Status of the water heater

During operation, the operation control knob shows the status of the water heater.

### 3.2.1 Operating modes

The LGL has 2 operating modes:

- OFF mode (see 3.2.1.1)
- ON mode

#### 3.2.1.1 OFF mode

In the **OFF mode** the water heater is deactivated. The operation control knob is set in the position [, and the temperature control knob is completely turned clockwise. The pilot flame is activated.

To prevent that the water in the system freezes, the frost protection is activated when the water heater is in **OFF mode**. The frost protection starts when the temperature of the water drops below 5 °C. The water heater will heat the water to 20 °C and then turns back to the **OFF mode**.

#### 3.2.1.2 ON mode

In the **ON mode** the water heater continuously responds to the heat demand. The operation control knob is set in the position [, and the temperature control knob is turned to one of the 5 positions. The pilot flame is activated and ignites the main burners when there is a heat demand.

## 4 Use

### 4.1 Turn on the water heater



#### Caution

Make sure that the water heater is filled with water before you turn on the water heater.

To start the water heater:

1. Remove the outer door (see 3).
2. Open the gas supply.
3. Turn the temperature control knob completely clockwise.
4. Turn the operation control knob to [,].
5. Push the operation control knob and simultaneously push the Piezo igniter button several times until the pilot flame burns.



#### Note

When the pilot flame burns, hold the operation control knob for approximately 20 seconds.

6. Release the operation control knob.
7. Look through the pilot flame inspection window to make sure that the pilot flame remains on.



#### Note

When the pilot flame extinguishes, wait for at least 5 minutes and repeat this procedure from step 5.

8. Turn the operation control knob to [,].
9. Turn the temperature control knob to the desired Temperature setting (see 4.1.1).
10. Replace the outer door.



## 4.1.1 Temperature setting

Use the temperature control knob to set the temperature:

- Position **1** = approximately 40°C
- Position **2** = approximately 50°C
- Position **3** = approximately 60°C
- Position **4** = approximately 70°C
- Position **5** = approximately 80°C



### Caution

Preferably turn the temperature control knob in position 3. Harmful scaling and lime build-up will be higher when using position 5. At lower temperature settings there is a higher risk of high legionella concentrations in the water.

When the water temperature reaches 90 °C, the safety thermostat cuts off the gas supply completely and the pilot flame goes out.

## 4.2 Turn off the water heater

### 4.2.1 Turn off for a short period

To turn off the water heater for less than 2 months, set the water heater in the **OFF mode** (see 3.2.1.1).



### Note

If the water heater stays in the **OFF mode** for more than 2 months and no water is drained, air bubbles may be formed in the water heater. This can lead to air in the water pipes.

### 4.2.2 Turn off for a long period

When the water heater needs to be turned off for more than 2 months, contact your service and maintenance engineer to decommission the water heater.

# 5 Introduction

## 5.1 About the water heater

The LGL water heater is intended for heating water for sanitary purposes.

The LGL is a gas-fired storage water heater. The flue gasses transfer their heat to the water

through an heat exchanger. The water heater has an open flue gas discharge connection.

## 5.2 Working principle

Cold water enters the tank through the water inlet (1). When the water temperature drops beneath the set temperature, the gas supply to the main burners is opened automatically and the water is heated. A heat exchanger (3) transfers the heat from the flue gasses to the water and the hot water leaves the tank through the water outlet (2).

The tank of the water heater has to be completely filled during operation. The tank at least must remain under mains water supply pressure at any time. Fresh cold water is immediately added when hot water is drawn from the water heater. A temperature sensor measures the water temperature.

*Fig. LGL water heater*

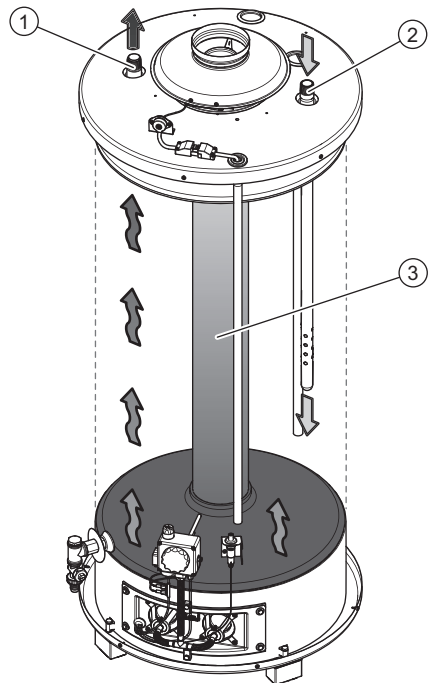

1. Water outlet
2. Water inlet
3. Heat exchanger

# 6 Safety

## 6.1 Safety instructions

For safety instructions on the use of the water heater, refer to Safety (see 2) in the User part of this manual.



### Warning

Installation, maintenance and service must be carried out by a qualified engineer in compliance with the general and local regulations imposed by the gas and water supply companies and the fire brigade. The appliance may only be installed in a room that complies with the requirements stated in national and local ventilation regulations (see 6).



### Caution

The water heater may only be moved in an upright position. After unpacking, make sure that the water heater is not damaged.

### Caution

Use of an incorrect roof flue terminal can cause the water heater to malfunction.

### Caution

Make sure that the diameter of the gas supply pipe is large enough to supply sufficient capacity to the water heater.

### Caution

Fill the water heater completely before use. Dry firing will damage the water heater.

### Caution

After installation or maintenance, always check that the appliance is gas tight and make sure that the gas supply pressure and the burner pressure are correct.  
If the gas supply pressure is not correct, contact your mains gas supply company. Do not use the water heater.



### Danger

Never deactivate the T.R.S.. Backdraft of flue gas can lead to a dangerous situation.



### Note

Any leakage from the tank and/or connections can cause damage to the immediate environment or floors below the level of the boiler room. Install the water heater above a waste water drain or in a suitable metal leak tray.

The leak tray must have an appropriate waste water drain and must be at least 5 cm deep with a length and width of at least 5 cm larger than the water heater.





## 6.2 Instructions on the water heater

The water heater has some safety instructions on its cover:

- The text "Read the installation instructions before installing the appliance".
- The text "Read the user instructions before putting the appliance into operation".

Also the packaging has some safety instructions:

- The text "Read the installation instructions before installing the appliance".
- The text "Read the user instructions before putting the appliance into operation".
- The text "The appliance may only be installed in a room that meets the required ventilation regulations".
- Some safety pictograms:

	CE approved
	This way up
	Fragile
	Keep dry
	Maximum stacking height is 2

## 6.3 Safety devices

Safety devices of the water heater:

<b>Gas control valve</b>	The gas control valve controls the gas supply to the burners and to the pilot burner.
<b>Thermocouple</b>	The thermocouple detects the presence of a pilot flame. When the pilot flame extinguishes, the gas supply is closed.
<b>T.R.S. (Thermal Reflux Safeguard)</b>	The T.R.S. detects the presence of returning flue gases on the draught diverter. The T.R.S. detects an increase of temperature in the edge of the draft diverter. When the temperature becomes too high, the gas supply is closed.

Safety devices of the installation:

<b>Inlet security group</b>	The inlet security group is the combination of the stop valve, a non return valve and a pressure relief valve. The inlet security group prevents excessive pressure in the tank and back flow of expansion water into the cold water main supply.
<b>Pressure-reducing valve</b>	The pressure-reducing valve reduces the water mains pressure, if necessary.
<b>Temperature and pressure relief valve (T&amp;P valve) (1)</b>	The T&P valve is a temperature and pressure relief valve which is activated when: <ul style="list-style-type: none"><li>- the temperature exceeds 97°C.</li><li>- the pressure exceeds 7 bar.</li></ul>

1- All installations have a T&P valve connection. Lochinvar recommends to use a T&P valve.

## 6.4 Environmental aspects

### 6.4.1 Recycling



The packaging material is environmentally friendly, recyclable and relatively easy to discard.

### 6.4.2 Disposal



Old end-of-life appliances contain materials that need to be recycled. When you discard devices at the end of their service life, you must obey local legislation related to waste disposal.

Never discard your old device together with regular waste. Put the device into a municipal waste collection depot for electrical and electronic equipment. If necessary, ask your supplier or your service and maintenance engineer for advice.

# 7 Water heater

## 7.1 Structure of the water heater

The water heater has the following main components:

<b>Tank</b>	The water is stored and heated up in the tank.
<b>Burners</b>	The burners (with a pilot flame) ignite the air and gas mixture to heat up the water.
<b>Gas control valve</b>	The gas control valve controls the gas supply to the burners.

Fig. Components water heater

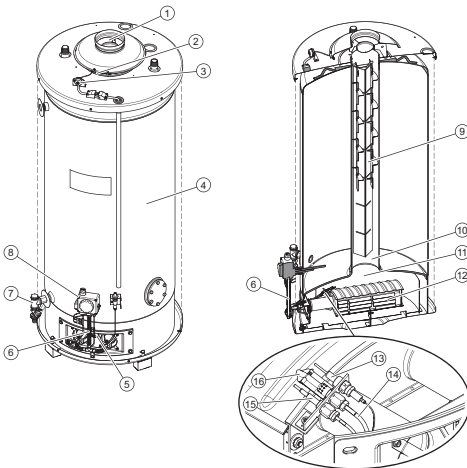

- |                            |                       |
|----------------------------|-----------------------|
| 1 Draught diverter         | 9 Flue baffle         |
| 2 T.R.S. sensor            | 10 Heat exchanger     |
| 3 T.R.S. thermostat        | 11 Combustion chamber |
| 4. Tank                    | 12 Burners            |
| 5 Burner tube              | 13 Thermocouple       |
| 6 Interrupter thermocouple | 14 Pilot pipe         |
| 7 Drain valve              | 15 Igniter            |
| 8 Gas control valve        | 16 Pilot burner       |

# 8 Installation



### Warning

The installation must be done by a qualified person, in compliance with general and local applicable regulations (see 6).



### Caution

The water heater may not be used in rooms where chemical substances are stored or used because of the risk of explosion and corrosion of the water heater. Some propellants, bleaching agents and degreasing agents etc. disperse of explosive vapors and/or cause accelerated corrosion. If the water heater is used in a room where such substances are stored or used, the warranty will be void.

For more safety instructions, refer to Safety instructions (see 6.1).

## 8.1 Packaging

Lochinvar recommends to unpack the water heater at or near its intended location. Remove the packaging material carefully to prevent damage to the water heater.

## 8.2 Conditions

The water heater must be installed in a location with adequate ventilation and a suitable flue gas discharge.

### 8.2.1 Ambient conditions

The installation site must be frost-free. If necessary, adjust the installation site to keep it frost-free.

Air humidity and ambient temperature	
Air humidity	Max. 93% RH at + 25 °C
Ambient temperature	Functionality: 0 < T < 40 °C

### 8.2.2 Maximum floor load

Refer to the building construction engineer and the general specifications in the appendices (see 12) to make sure that the maximum floor load is sufficient for the weight of the water heater.

## 8.2.3 Water composition

The water must comply with the regulations for drinking water for human consumption.

Water composition	
Hardness (alkaline earth ions)	> 1.00 mmol/l: - German hardness > 5.6° dH - French hardness > 10.0° fH - English hardness > 7.0° eH - CaCO <sub>3</sub> > 100 mg/l
Conductivity	> 125 µS/cm
Acidity (pH value)	7.0 < pH value < 9.5



### Note

If the water specifications differ from the specifications in the table, the tank protection cannot be guaranteed, refer to Warranty (see 3).

## 8.2.4 Working clearances

Make sure that there is sufficient clearance to access the water heater:

- 50 cm in front of the water heater (AA).
- 50 cm at the left and right side of the water heater (BB).
- 100 cm at the top of the water heater.

Fig. Working clearances

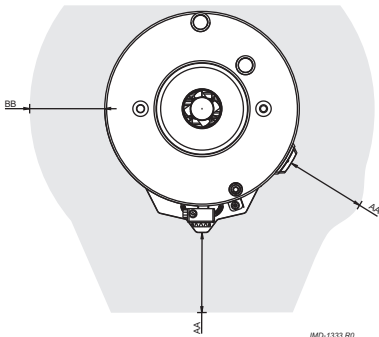

## 8.2.5 Placement of the water heater

Before you install the water connections and gas connections, place the water heater on the correct position and make sure that the water heater is level.

## 8.3 Installation diagram

Fig. Installation diagram

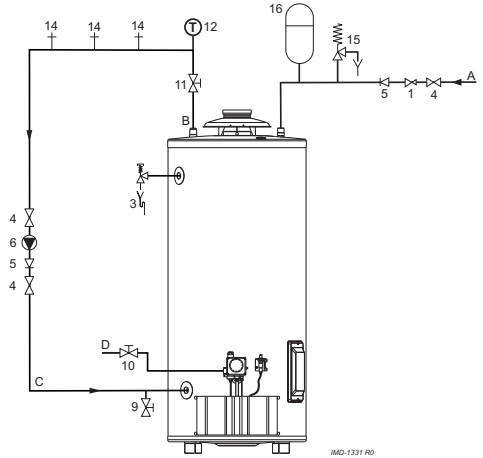

1. Pressure reducing valve (mandatory if the mains water pressure is too high)
  3. T&P valve (optional)
  4. Stop valve (recommended)
  5. Non-return valve
  6. Circulation pump (optional)
  9. Drain valve
  10. Manual gas valve
  11. Service stop valve
  12. Temperature gauge (optional)
  14. Draw-off point
  15. Expansion valve
  16. Expansion vessel
- A. Cold water supply  
B. Hot water outlet  
C. Circulation pipe (optional)  
D. Gas supply

Use this installation diagram when you:

- install the water connections (see 8.4)
- install the gas connection (see 8.5)
- fill the water heater (see 8.7.1)
- drain the water heater (see 8.8)

## 8.4 Water connections

### 8.4.1 Cold water connection

Install the cold water connection:

1. Install an approved stop valve (4), as required by the applicable regulations (see 6).
2. Install an approved pressure reducing valve (1) to prevent that the pressure in the cold water supply pipe exceeds the maximum working pressure of the tank, 8 bar. Refer to the Technical details.
3. Install a non-return valve (5).
4. Install an expansion valve (15).
5. Connect the overflow connection of the expansion valve, to an open waste water pipe.
6. Install an expansion vessel (16).

### 8.4.2 Hot water connection



#### Note

Insulate long hot water pipes to prevent unnecessary energy loss.

Install the hot water connection:

1. Install a stop valve (11) in the hot water outlet pipe for service reasons.
2. If applicable, install a temperature gauge (12).
3. Install a T&P valve (3).

### 8.4.3 Circulation connection

Install a circulation system when an immediate flow of hot water at draw-off points is required. This improves comfort and reduces water wastage.



#### Note

Use the drain valve connection (9) as a connection of the circulation pipe on the water heater.

#### Note

Make sure that the circulation pump has the correct capacity for the length and resistance of the circulation system.

Install a circulation pump:

1. Install a circulation pump (6).
2. Install a non-return valve (5) after the circulation pump to make sure that the direction of circulation is guaranteed.
3. Install a stop valve (4) before the circulation pump.
4. Install a stop valve (4) after the non-return valve.
5. Connect the circulation pipe to the drain valve (9).

### 8.4.4 Drain valve

Install the drain valve:

1. Fasten the drain valve (9) in the connection in the front of the water heater.
2. Place the cap over the connection to make it watertight.

## 8.5 Gas connection



#### Caution

Make sure that the gas supply pipe has the correct diameter and length to supply sufficient capacity to the water heater.

#### Caution

Make sure that the gas supply pipe is clean. Contamination in the pipe can cause damage to the gas control valve, during operation.

#### Caution

Install a manual gas valve on a spot accessible for the user.

Install the gas connection:

1. Install a manual gas valve (10) in the gas supply pipe.
2. Make sure that the gas pipe is clean before use. If necessary, remove the contamination from the pipe.
3. Close a manual gas valve.

4. Install the gas supply pipe to the gas control valve.
5. Make sure that there are no gas leaks.

## 8.6 Flue gas discharge



### Caution

It is not allowed to make changes to the flue gas discharge or to apply casings on it.

Install the flue gas discharge:

1. Install the draught diverter on top of the water heater. (see 8.6.1)
2. Install the T.R.S.
3. Install the discharge pipe. (see 8.6.3)

### 8.6.1 Draught diverter

Install the delivered draught diverter on top of the water heater.

For correct installation of the draught diverter, please refer to the installation instructions delivered with the draught diverter.

*Fig. Install the draught diverter*

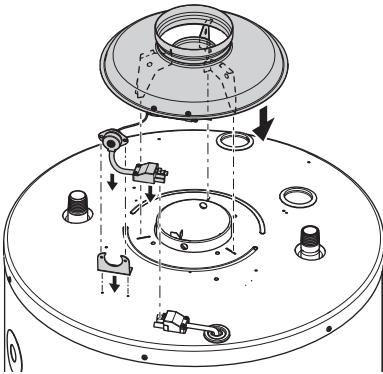

### 8.6.2 T.R.S. (Thermal Reflux Safeguard)

The T.R.S. (Thermal Reflux Safeguard) is installed on the draught diverter.



### Note

Make sure that the temperature probe is positioned at the front side of the water heater. If necessary, reinstall the draught diverter.

To install the T.R.S.:

1. Remove the screws from the bracket.

2. Use the screws to install the bracket on the water heater.
3. If necessary, use the screws to install the T.R.S. thermostat in the bracket.
4. Connect the plug of the T.R.S. thermostat.



### Caution

Make sure that the T.R.S. sensor does not have sharp kinks. This can lead to malfunctions which can damage the equipment.

*Fig. Install the T.R.S. thermostat*

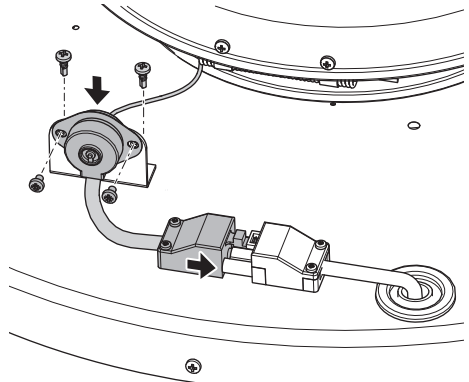

### 8.6.3 Discharge pipe

Install a vertical discharge pipe directly on top of the draught diverter. This pipe must have at least 50 cm of length before the first bend.



### Note

Make sure that the discharge pipe is protected against corrosion and has at least the same diameter of the draught diverter.

## 8.7 Commissioning

To commission the water heater:

1. Fill the water heater (see 8.7.1)
2. Check the burner pressure (see 8.7.2)
3. Turn on the water heater (see 8.7.3)

### 8.7.1 Filling

Refer to the installation diagram (see 8.3) when you fill the water heater:

1. Open the stop valve (11) in the hot water supply pipe.
2. If applicable, open the stop valves (4) of the circulation pipe (C).

3. Make sure that the drain valve (9) is closed.
4. Open all hot water draw-off points (14) to bleed the entire installation of air.
5. Open the valve of the inlet security group (2) in the cold water supply pipe (A). Cold water flows into the water heater.
6. Fill the water heater until cold water flows out of all opened draw-off points. The water heater is completely full.
7. Make sure that no water comes out of the pressure relief valve of the inlet security group (2) or the T&P valve (3). If water comes out:
  - Examine if the water supply pressure is greater than the specified value in the Technical details. If necessary, install a pressure reducing valve (1).
  - Examine if the pressure relief valve of the inlet cold security group in the protected cold supply set-up is installed correctly and is not defect. If necessary, replace the expansion valve.
8. Close all hot water draw-off points.

## 8.7.2 Burner pressure

Make sure that the burner pressure is set correctly in order to check the nominal load.

Check the burner pressure:

1. Remove the sealing screw of the test nipple.
2. Connect a pressure gauge to the test nipple as soon as you smell gas.
3. Turn on the water heater (see 4.1).
4. If necessary, create a heat demand:
  - Use a hot water draw-off point to tap water, or
  - Use the temperature control knob to raise the setpoint of the water temperature (see 4.1.1).
5. Wait about 1 minute.
6. Use the pressure gauge to read the burner pressure and compare it with the value from the appendix Gas details (see 12.4).
7. If necessary, correct the burner pressure with the pressure adjustment screw:
  - a) Remove the temperature control knob by pulling it straight out. The burner pressure adjustment screw ("pr adj") will be visible.
  - b) Turn the screw anticlockwise to decrease the burner pressure or clockwise to increase the burner pressure.
  - c) Replace the temperature control knob.
8. Turn the water heater off (see 4.2).
9. Disconnect the pressure gauge.
10. Replace the sealing screw and tighten it on the test nipple.

Fig. Set nominal load of the gas burners

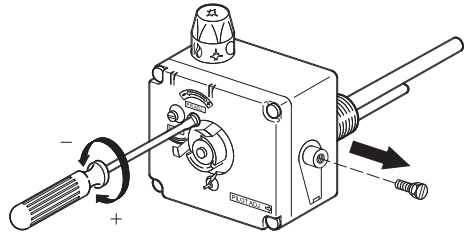

## 8.7.3 Turn on the water heater

Refer to the procedure in the user part to Turn on the water heater (see 4.1).

## 8.8 Decommissioning

To decommission the water heater:

1. Turn off the water heater (see 8.8.1)
2. Drain the water heater (see 8.8.2)

### 8.8.1 Turn off the water heater

Refer to the procedure in the user part to Turn off the water heater (see 4.2).

### 8.8.2 Draining

Refer to the installation diagram (see 8.3) when you drain the water heater:

1. Close the manual gas valve (10).
2. If applicable, close the service stop valve (11) in the hot water pipe.
3. Close the stop valve (10).
4. Open the drain valve (9).
5. Aerate the entire installation of air until the water heater is completely drained.



#### Note

Disconnect and tilt the water heater in the direction of the drain valve when the water heater needs to be drained completely.

## 9 Conversion of gas type



#### Caution

Conversion of the water heater may only be carried out by a qualified person.

Use a conversion kit to convert the water heater when the water heater has to operate on a gas



category other than that for which the water heater has been configured at the factory.

You can order the conversion kit you need from the supplier of your water heater. The conversion kit contains all the parts needed to do the conversion and an instruction how to do the conversion.

The following conversions are possible:

- Conversion from natural gas to LPG.
- Conversion from LPG to natural gas.
- Conversion from natural gas to natural gas.



### Caution

After the conversion, make sure that the water heater is gas-tight. Make sure that the supply pressure and the burner pressure have the correct value.

## 10 Maintenance

The water heater needs maintenance at least once a year. The maintenance interval is determined by the water quality, the average burning time each day and the set water temperature.

To determine the correct interval, Lochinvar recommends to do a system check on both the water and the gas side, three months after installation.



### Note

Do maintenance to maintain an effective and efficient transfer of heat to the water. This significantly increases the service life of the water heater.

### Note

When needed, spare parts can be ordered. To be sure that you receive the correct spare parts, look at the data plate for the full serial number, the water heater model, and the used gas category. Use this information when you order the spare parts.

Do the following maintenance activities:

- [Performance check](#) (see 10.1)
- [Water-side maintenance](#) (see 10.2)
- [Gas-side maintenance](#) (see 10.3)

## 10.1 Performance check

Check if the performance of all components is correct:

1. Make sure that the water heater operates the operating cycle correctly.
2. Make sure that the color of the flame is blue.
3. If applicable, make sure that the T&P valve operates correctly.  
Open the T&P valve pressure relief and make sure that water spurt out.



### Warning

Hot water can come out of the T&P valve.

4. Make sure the pressure relief connection of the inlet security group operates correctly. Open this pressure relief and make sure that water spurt out.
5. Make sure the pressure of the gas supply is correct:
  - a) Remove the sealing screw of the test nipple under the gas supply connection.
  - b) Connect a pressure gauge to the test nipple as soon as you smell gas.
  - c) Use the pressure gauge to read the gas supply pressure and compare it with the value from the appendix [Gas details](#) (see 12.4).
  - d) Disconnect the pressure gauge.
  - e) Replace the sealing screw and tighten it on the test nipple.
6. [Make sure the burner pressure is correct](#) (see 8.7.2).

## 10.2 Water-side maintenance

To do water side maintenance:

- [Inspect the anode](#) (see 10.2.1)
- [Inspect the inlet security group](#) (see 10.2.2)
- [Descale the tank](#) (see 10.2.3)

### 10.2.1 Inspect the anode

The life cycle of the anode is determined by the quality and the quantity of the water that flows through the water heater. Inspect the anode at least once a year to make sure that the tank is protected against corrosion.

To inspect the anode:

1. Close the pressure reducing valve in the cold water supply.
2. Open the nearest hot water tap to reduce the water pressure in the water heater.

3. Use a wrench to loosen the anode.
4. Take the anode out of the water heater.
5. Inspect the volume of the anode. When the anode is consumed for 60 % or more, replace the anode.



**Note**

If the anode needs to be replaced, always use an anode of the same type. Please refer to the type and the serial number on the data plate.

6. Place the anode in the water heater.
7. Use a wrench to fasten the anode. Make sure that the connection is watertight.



**Note**

Never install an anode isolated from the metal tank.

*Fig. Inspect the anode*

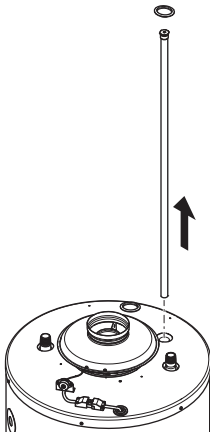

### 10.2.2 Inspect the inlet security group

To inspect the inlet security group:

1. Check if the cold water supply is open. If not, open the cold water supply.
2. Open the relief valve of the inlet security group and make sure that the water flows out with a full jet of water.
3. Close the relief valve.
4. Check if the water is drained through the tundish. If not, remove the blockage.
5. Check the water flow again by opening the relief valve.

### 10.2.3 Descale the tank

To descale and clean the tank:

1. Decommission the water heater (see 8.8).
2. Loosen the two screws to remove the cover plate on side of the tank.
3. Push the isolating material aside to see the cleaning opening.
4. Loosen the 6 bolts (4).
5. Remove the cleaning opening cover (3).
6. Remove the gasket (2).
7. Inspect the tank and remove the loose scale deposits and contamination:
  - a) Remove the scale and contamination by hand.
  - b) If necessary use a descaling agent to remove the scale and contamination from the tank. Contact Lochinvar for advice on what descaling agent to use.
8. Replace the gasket.
9. Close the cleaning opening.
10. Use a torque wrench to tighten the bolts with a maximal torque of 50 Nm to prevent damage to the tank
11. Put the isolating material in place.
12. Put the cover plate in place and tighten the two screws.
13. Fill the water heater.

*Fig. Cleaning opening*

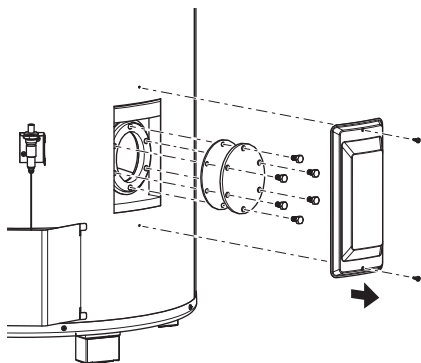

### 10.3 Gas-side maintenance

Do gas side maintenance when the water heater does not operate correctly.

To do gas side maintenance:

- Clean the burners (see 10.3.1)
- Clean the combustion chamber (see 10.3.2)

### 10.3.1 Clean the burners

To clean the burners:

1. Remove the outer door.
2. Close the main gas supply and/or the manual gas valve, refer to [Installation diagram](#) (see 8.3).
3. Disconnect the cable from the piezo igniter.
4. Disconnect the two slide contacts of the T.R.S.
5. Disconnect the pilot pipe from the gas control valve.
6. Disconnect the thermocouple from the gas control valve.
7. Disconnect the burner tube from the gas control valve.

*Fig. Disconnect the burners*

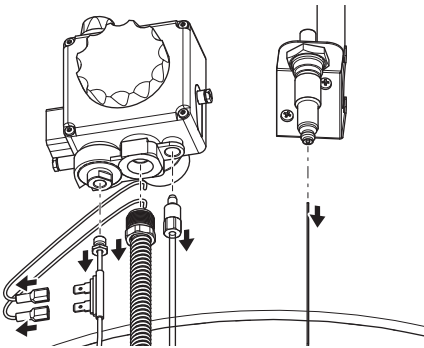

8. Loosen the two bolts to disconnect the burners from the combustion chamber.

*Fig. Loosen the bolts*

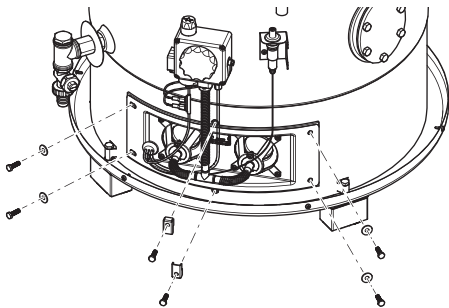

9. Take the burners out of the water heater.

*Fig. Remove the burners*

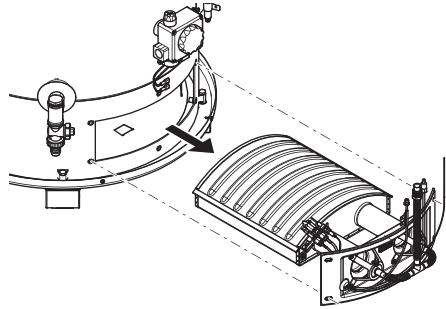

10. Clean the burners with a soft brush.
11. Clean the pilot burner or, when necessary, replace the pilot burner.

### 10.3.2 Clean the combustion chamber

Use a vacuum cleaner and a soft brush to clean the combustion chamber (1) of the heat exchanger.

### 10.3.3 Assemble the burners

Assemble the burners when the burners and the combustion chamber both are cleaned:

1. Replace the burners in the water heater and fasten the two bolts.
2. Connect the burner tube to the gas control valve.
3. Use a wrench to tighten the burner tube.
4. Connect the thermocouple to the gas control valve.
5. Use a wrench to tighten the thermocouple (max. 1/4 turn clockwise, it only needs to make contact).
6. Connect the pilot pipe to the gas control valve.
7. Connect the two slide contacts of the T.R.S. to the thermocouple.
8. Connect the ignition cable to the piezo igniter.
9. Open the main gas supply and/or the manual gas valve, refer to [Installation diagram](#) (see 8.3).

### 10.3.4 Finalization

When all maintenance activities are finished, place the outer door back on the water heater. After that:

1. If necessary, [fill the water heater](#) (see 8.7.1).

2. Make sure the gas supply pressure is correct. If the gas supply pressure is not correct, contact your mains gas supply company. Do not use the water heater.
3. Make sure that the burner pressure is correct, refer to [burner pressure](#) (see 8.7.2).
4. [Turn on the water heater](#) (see 8.7.3).

# 11 Troubleshooting

## 11.1 General

When the water heater has an error, do the following tests:

- Test the safety thermostat
- [Test the T.R.S.](#) (see 11.1.2)
- Condensation of flue gases

Contact you maintenance and service engineer if the error persists.

### 11.1.1 Safety thermostat

All water heaters are equipped with a safety thermostat. When the water temperature is too high (>90°C), the gas supply is shut off. The safety thermostat stays switched on until the water temperature is below 45°C.

When the water temperature is below 45°C:

1. [Turn on the water heater](#) (see 8.7.3), because the main burner and the pilot burner are OFF.
2. [Turn the temperature control knob to a lower position](#) (see 4.1.1) and test if the pilot flame remains on.



#### Note

Repeated extinguishing of the pilot flame at higher temperatures, shows that the safety thermostat is switched on.

### 11.1.2 T.R.S. (Thermal Reflux Safeguard)

All water heaters are equipped with a Thermal Reflux Safeguard (T.R.S.). When the T.R.S. detects a temperature that is too high (>90°C), the gas supply is shut off. The T.R.S. stays switched on until the thermostat is reset.

1. Check the flue discharge for blockage. If necessary, remove the blockage.
2. Push on the reset button on the T.R.S. thermostat to reset the T.R.S.
3. [Turn on the water heater](#) (see 4.1), because the main burner and the pilot burner are OFF.



#### Note

If the T.R.S. switches of the water heater repeatedly, this indicates something is wrong with the flue discharge.

Fig. Reset the safety thermostat

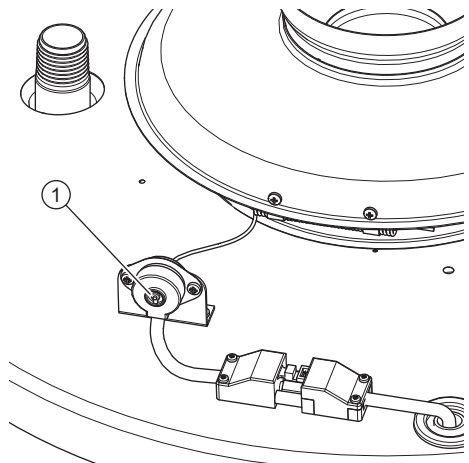

1 Reset button

### 11.1.3 Condensation

Condensation of flue gases can occur on the cold surfaces of the combustion chamber and the flue gas discharge pipe when the water heater is filled with cold water or when the warm water usage is very high. Condense water can drop on the burners which can lead to hissing noise. This noise will disappear when the water heater has reached its normal operating temperature again.





#### Caution

Never take the water heater in operation when the cold water supply is closed.

## 11.2 General errors

Indication	Cause	Measure
<b>Gas smell</b>	There is a gas leak.	<ul style="list-style-type: none"> <li>- Close the main gas valve at once.</li> <li>- Do not operate any switches.</li> <li>- No naked flames.</li> <li>- Ventilate the boiler room.</li> <li>- Immediately contact your installation engineer or your local gas company.</li> </ul>
<b>Insufficient or no hot water - Pilot flame is off</b>	Contaminated pilot burner.	Clean the pilot burner.
	Flue gas discharge is blocked.	Find the cause of the blockage and solve it.
	Safety thermostat is switched on.	Turn the temperature control knob to a lower position. <u>Turn on the water heater</u> (see 4.1).
	Control knob is in position <b>【●】</b>	<u>Turn on the water heater</u> (see 4.1).
	Thermocouple is not working.	Replace thermocouple.
	Thermocouple does not make contact.	Restore contact. <u>Turn on the water heater</u> (see 4.1).
	Gas supply is closed.	Open the gas supply and <u>Turn on the water heater</u> (see 4.1).
	T.R.S. is not connected to the thermocouple.	Slide the two connectors of the T.R.S. on the thermocouple connections. <u>Turn on the water heater</u> (see 4.1).
	T.R.S. has closed the gas supply	Push the reset button (when available) on the safety thermostat. <u>Turn on the water heater</u> (see 4.1). If this error keeps occurring, contact your installer.
Gas control valve is broken.	Replace the gas control valve.	

Indication	Cause	Measure
<b>Insufficient or no hot water - Pilot flame is on</b>	Temperature set too low.	Turn the temperature control knob to a higher position.
	Thermocouple is broken.	Replace thermocouple.
	Control knob is in position  (pilot flame is on).	Turn the temperature control knob to the desired position (preferably position <b>4</b> ). The water heater now functions fully automatic.
	Hot water storage is empty.	Reduce hot water usage so the water heater has enough time to heat the water.
	Condensation of flue gases.	See Condensation.
	Cause cannot be determined.	Turn the operation control knob to  , close the gas supply valve and contact your installer.
<b>Water leakage</b>	There is a leakage from a threaded water connection.	Tighten the threaded connection.
	There is a condensate leakage.	Reduce hot water usage so the water heater has enough time to heat the water.
	There is a leakage from another nearby water heater or pipe segment.	Trace the leakage.

## 12 Appendices

### 12.1 Technical details

Description	Unit	LGL 75	LGL 85
Capacity	l	273	365
Empty Weight	kg	124	151
Maximum floor load	kg	392	509
Maximum operating pressure	kPa (bar)	550 (5.5)	550 (5.5)
Control thermostat - adjustment range	°C	40-80	40-80
Control thermostat - factory setting	°C	30	30

Description	Unit	LGL 75	LGL 85
Number of anodes	-	1	1
Heating time $\Delta T = 45\text{ }^{\circ}\text{C}$	min.	35	47

## 12.2 Dimensions

Size	Description	Unit	LGL 75	LGL 85
<b>Dimensions water heater</b>				
A	Height	mm	1595	1780
D	Width	mm	645	705
E	Depth	mm	735	795
G	Flue gas outlet	mm	130	130
<b>Dimensions connections</b>				
1	Cold water supply connection (female)	-	1"	1 1/4"
2	Hot water outlet connection (female)	-	1"	1 1/4"
3	Gas control valve connection (male)	-	Rp 1/2"	Rp 1/2"
4	Drain valve connection (female)	-	3/4"	3/4"
5	T&P-valve connection (female)	-	3/4"	3/4"
6	Cleaning/inspection opening	mm	135x105	135x105

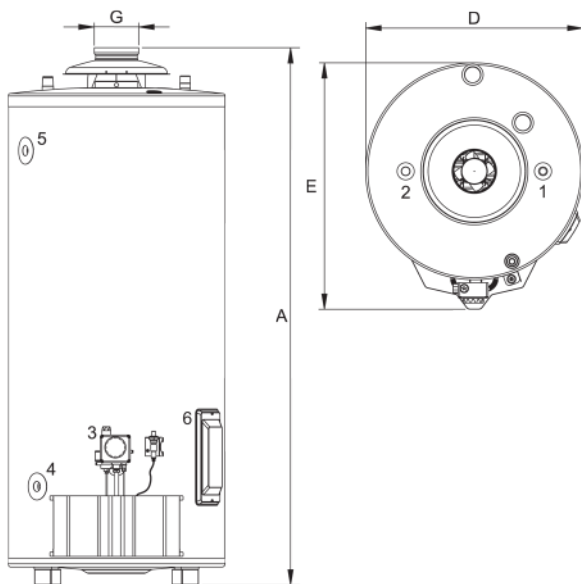



## 12.3 EcoDesign details

Description	Unit	LGL 75	LGL 85
<b>Declared load profile</b>			
Load profile	-	XL	XXL
Energy efficiency class (energy label)	-	B	C
Energy efficiency	%	58	58
Daily electricity usage	kWh	0	0
Daily fuel consumption	kWh GCV	37.940	42.545
Mixed water 40°C (V40)	l	1246	648
<b>Additional load profile</b>			
Load profile	-	XXL	3XL
Energy efficiency class (energy label)	-	C	-
Energy efficiency	%	55	65
Daily electricity usage	kWh	0	0
Daily fuel consumption	kWh GCV	44.315	72.544
Mixed water 40°C (V40)	l	538	649

## 12.4 Gas details

Description	Unit	LGL 75	LGL 85
<b>Gas category 2H (G20)</b>			
Diameter main orifice	mm	2.75	3.00
Diameter orifice pilot burner	mm	2 x 0.27	2 x 0.27
Nominal load (Gross)	kW	22.1	21.0
Nominal output	kW	16.8	16.6
Supply pressure	mbar	20.0	20.0
Burner pressure	mbar	12.2	9.0

<b>Description</b>	<b>Unit</b>	<b>LGL 75</b>	<b>LGL 85</b>
Gas consumption <sup>(1)</sup>	m <sup>3</sup> /h	2.1	2.0
NO <sub>x</sub> -emission	mg/kWh GCV	22	30
Mass flow rate flue gases (nominal load)	kg/h	74	72
Flue gas temperature (nominal load)	°C	142	125
<b>Gas category 3+ (G30)</b>			
Diameter main orifice	mm	1.45	1.45
Diameter orifice pilot burner	mm	2 x 0.16	2 x 0.16
Nominal load (Gross)	kW	18.3	16.2
Nominal output	kW	14.3	13.1
Supply pressure	mbar	30.0	30.0
Burner pressure	mbar	-	-
Gas consumption <sup>(1)</sup>	kg/h	1.3	1.2
NO <sub>x</sub> -emission	mg/kWh GCV	13	15
Mass flow rate flue gases (nominal load)	kg/h	73	71
Flue gas temperature (nominal load)	°C	142	125
<b>Gas category 3+ (G31)</b>			
Diameter main orifice	mm	1.45	1.45
Diameter orifice pilot burner	mm	2 x 0.16	2 x 0.16
Nominal load (Gross)	kW	17.9	17.8
Nominal output	kW	13.9	14.4
Supply pressure	mbar	37.0	37.0
Burner pressure	mbar	-	-
Gas consumption	kg/h	1.3	1.3
NO <sub>x</sub> -emission	mg/kWh GCV	9	9

<b>Description</b>	<b>Unit</b>	<b>LGL 75</b>	<b>LGL 85</b>
Mass flow rate flue gases (nominal load)	kg/h	72	70
Flue gas temperature (nominal load)	°C	142	125

## 12.5 Declaration of conformity



### EEC - Declaration of Conformity

**Supplier:** Lochinvar Limited  
7 Lombard Way  
The MXL Centre  
Banbury - United Kingdom

hereby declares that the following products:

**Product description:** Gas Fired Water Heater  
**Product family name:** Knight Low NOx  
**Product models:** LGL 75, LGL 85

on the assumption that the installation instructions have been followed are complaint to:

- **Gas Appliance Regulation (GAR) - 2016/426**  
- EN 89:2015
- **Pressure Equipment Directive (PED) - 97/23/EG**  
- Based on Art. 3, Sub 3. (PS < 10 bar, pressure vessel for non-hazardous fluids)
- **ECO Design Directive (ErP) - 2009/125/EG**  
- Commission regulation No. 814/2013 based on notices 2014/C - 207/03
- **Energy Labelling Directive - 2010/30/EG**  
- Commission regulation No. 812/2013

as stated in the EC type-examination report, 180100364, by KIWA Gastec Certification b.v., The Netherlands.

**Company:**  
Lochinvar Limited

**Date:**  
September 1, 2018

**Signature:**

E. van Driel  
Managing Director

## 12.6 Warranty

### Article 1: General warranty

If within 1 (one) year of the invoice date or commissioning date of a water heater supplied by Lochinvar Ltd., following verification, and at the sole discretion of Lochinvar Ltd., an assembly or part (with exclusion of the tank) proves to be defective or fails to function correctly due to manufacturing and/or material defects, then Lochinvar Ltd. shall repair or replace this assembly or part.

### Article 2: Warranty

If within 3 (three) years of the invoice date or commissioning date of a water heater supplied by Lochinvar Ltd., following verification, and at the sole discretion of Lochinvar Ltd., the enamel-lined steel tank proves to be leaking due to rust or corrosion occurring on the water side, then Lochinvar Ltd. shall offer to replace the defective water heater with an entirely new water heater of equivalent size and quality. The warranty period given on the replacement water heater shall be equal to the remaining warranty period of the original water heater that was supplied.

### Article 3: Conditions for installation and use

The warranty set out in articles 1 and 2 will apply solely under the following conditions:

1. The water heater is installed under strict adherence to Lochinvar Ltd. installation instructions for the specific model, and must be in accordance with the relevant requirements of the Gas Safety Regulations, Building Regulations, I.E.E. Regulations and the byelaws of the local water undertaking. The installation should also be in accordance with any relevant requirements of the local gas distributor and local authority.
2. The water heater remains installed at the original site of installation.
3. The water heater is used exclusively with drinking water, which at all times can freely circulate (a separately installed heat exchanger is mandatory for heating saline water or corrosive water).
4. The tank is safeguarded against harmful scaling and lime build-up by means of periodic maintenance.

5. The water temperatures in the heater do not exceed the maximum setting of the thermostats, which form a part of the water heater.
6. The water pressure and/or heat load do not exceed the maximum values stated on the water heater rating plate.
7. The water heater is installed in a non-corrosive atmosphere or environment.
8. The water heater is connected to a protected cold supply arrangement, which is: approved by the relevant authority; with sufficient capacity for this purpose; supplying a pressure no greater than the working pressure stated on the water heater; and where applicable by a likewise approved temperature and pressure relief valve, fitted in accordance with installation instructions of Lochinvar Ltd. applying to the specific model of water heater, and further in compliance with Building Regulations, local authority installation byelaws and the Water Supply (Water Fittings) Regulations 1999.
9. The water heater is at all times fitted with cathodic protection. If sacrificial anodes are used for this and these anodes have reduced in size by more than 40% at any point along their length or if they are severely pitted, new anodes should be fitted. Particular attention should be paid to the ends of each anode to ensure excessive localized depletion has not occurred. Where anodes are covered with particles they should be cleaned; for reference, when new, the anode has a diameter of 21 mm. When power anodes are used, it is important to ensure that they continue to work properly.

### Article 4: Exclusions

The warranty set out in articles 1 and 2 will not apply in the event of:

1. damage to the water heater caused by an external factor;
2. misuse, neglect (including frost damage), modification and incorrect and/or unauthorized use of the water heater;
3. contaminants or other substances having been allowed to enter the tank;
4. any attempts at repair to a defective water heater other than by an approved service engineer;
5. the conductivity of the water being less than 125  $\mu\text{S}/\text{cm}$  and/or the hardness (alkaline earth ions) of the water being less than 1.00 mmol/litre;
6. unfiltered, recirculated water flowing through or being stored in the water heater.

## **Article 5: Scope of the warranty**

The obligations of Lochinvar Ltd. pursuant to the specified warranty are limited to free delivery from the warehouse of the replacement assemblies, parts or water heater, respectively. Labor, installation and any other costs associated with the replacement will not be accepted by Lochinvar Ltd.

## **Article 6: Claims**

A claim on grounds of the specified warranty must be submitted to the dealer from whom the water heater was purchased, or to another authorized dealer of Lochinvar Ltd.. Inspection of the water heater as referred to in articles 1 and 2 shall take place in one of the laboratories of Lochinvar Ltd.

## **Article 7: Obligations of Lochinvar Ltd.**

Lochinvar Ltd. grants no other warranty or guarantee over its water heaters nor the (assemblies or parts of) water heaters supplied for replacement, other than the warranty expressly set out in these conditions. Under the terms of the supplied warranty, Lochinvar Ltd. is not liable for damage to persons or property caused by (assemblies or parts, or the glass-lined steel tank of) a (replacement) water heater that it has supplied.





7 Lombard Way, The MXL Centre, Banbury, Oxon, OX16 4TJ  
Tel: +44(0) 1295 269 981, Fax:+44(0) 1295 271 640, Email: info@lochinvar.ltd.uk  
www.lochinvar.ltd.uk

*Lochinvar Ltd reserves the right to change specifications without prior notice*