

EcoShield™ Gas Fired Condensing Water Heaters

Installation, Commissioning, & Maintenance instructions

MODELS

SHW35-245CE

SHW46-325CE

SHW61-325CE

SHW86-410CE

SHW116-410CE

SHW146-410CE



Table of Contents

1.0	INTRODUCTION	5
2.0	SAFETY GUIDELINES	6
2.1	GENERAL DESCRIPTION OF SAFETY SYMBOLS USED.....	6
2.2	WHAT TO DO IF YOU SMELL GAS.....	7
3.0	PRINCIPLE PARTS	8
4.0	TECHNICAL DATA	10
5.0	DIMENSIONS AND CLEARANCE	11
5.1	DIMENSIONS.....	11
5.2	CLEARANCES.....	12
6.0	GENERAL REQUIREMENTS	13
6.1	RELATED DOCUMENTS.....	13
7.0	WATER QUALITY	14
8.0	LOCATION	14
8.1	PLANT ROOM REQUIREMENTS.....	14
8.2	GENERAL REQUIREMENTS.....	14
8.3	CONDENSATE DRAIN.....	14
9.0	GAS SUPPLY	15
9.1	SERVICE PIPES.....	15
9.2	METERS.....	15
9.3	GAS SUPPLY PIPES.....	15
9.4	BOOSTED SUPPLIES.....	15
9.5	PLANT-ROOM CONTROL VALVE.....	15
9.6	EQUIPMENT GAS SYSTEM LEAK CHECK.....	15
10.0	FLUE SYSTEM	16
10.1	FLUE SYSTEM GENERAL REQUIREMENTS.....	16
10.2	FLUE DISCHARGE.....	18
10.3	CONDENSATE DRAIN.....	18
10.4	FLUE SYSTEM GENERAL REQUIREMENTS.....	19
10.5	APPROVED FLUE SYSTEM.....	19
10.6	INSTALLATION PRECAUTIONS.....	19
10.7	CONDENSATE DRAIN.....	19
10.8	TYPE B ₂₃ CONVENTIONAL FANNED FLUE.....	19
10.9	ROOM SEALED (TYPE C) FLUE ASSEMBLY.....	20
10.10	C13 CONCENTRIC HORIZONTAL FLUE SYSTEMS.....	22
10.11	HORIZONTAL FLUE TERMINAL INSTALLATION.....	23
10.12	FLUE TERMINAL GUARDING.....	23
10.13	C33 CONCENTRIC VERTICAL FLUE SYSTEMS.....	24
10.14	VERTICAL FLUE TERMINAL INSTALLATION.....	24
10.15	C ₄₃ COMMON VENTED FLUE SYSTEMS IN MULTI FLOOR BUILDINGS.....	30
10.16	C ₅₃ (TWIN PIPE) FLUE SYSTEMS.....	31
10.17	FLUE TERMINAL GUARDING.....	35
10.18	TYPE B ₂₃ (CONVENTIONAL FLUE WITH FAN ASSISTANCE).....	36
10.19	C ₆₃ CERTIFIED FLUE SYSTEMS.....	37
11.0	AIR SUPPLY	38
11.1	COMBUSTION VENTILATION.....	38
11.2	COOLING VENTILATION.....	38
12.0	WATER CONNECTIONS	39
12.1	GENERAL.....	39
12.2	OPEN VENTED SYSTEM ARRANGEMENT.....	39
12.3	UNVENTED SYSTEM ARRANGEMENT.....	40
13.0	ELECTRICAL SUPPLY	42
13.2	EXTERNAL CONTROLS.....	43
13.3	MAINS POWER SUPPLY.....	43
13.4	LOW VOLTAGE CONNECTOR STRIP.....	44
13.5	ELECTRICAL CONNECTIONS.....	45
13.6	FUSES.....	45
13.7	ARC WELDING PRECAUTIONS.....	45
13.8	WIRING DIAGRAM.....	46
13.9	LADDER DIAGRAM.....	47
14.0	USER CONTROL INTERFACE	48
14.1	GENERAL.....	48
14.2	USER CONTROL INTERFACE PANEL.....	48
14.3	SEQUENCE OF OPERATION.....	49
15.0	COMMISSIONING AND TESTING	51
15.1	ELECTRICAL INSTALLATION.....	51
15.2	GAS INSTALLATION.....	51
15.3	WATER CONNECTIONS.....	51
15.4	COMMISSIONING THE EQUIPMENT.....	51
15.5	TEMPERATURE ADJUSTMENT PROCEDURE.....	52
15.6	INSTALLATION NOISE.....	52
16.0	LPG FUEL	53
16.1	RELATED DOCUMENTS.....	53
16.2	CONVERSION TO LPG.....	53
16.3	LPG COMMISSIONING AND TESTING.....	56
17.0	MAINTENANCE	57
17.1	GENERAL.....	57
17.2	BURNER INSPECTION.....	57
17.3	BURNER REMOVAL.....	57
17.4	CLEANING THE HEAT EXCHANGER.....	58
17.5	DRAINING THE WATER HEATER SYSTEM.....	58
17.6	STORAGE VESSEL: INSPECTION AND CLEANING.....	58
17.7	SACRIFICIAL ANODES: INSPECTION AND REPLACEMENT.....	59
17.8	REFILLING THE SYSTEM.....	59

17.9	OTHER CHECKS	59
18.0	USER CONTROL INTERFACE SETTINGS	61
18.1	TIME AND DATE	61
18.2	USER ADJUSTABLE PARAMETERS SCREEN	61
18.3	INSTALLER ADJUSTABLE PARAMETERS SCREEN	62
18.4	PASTEURISATION FUNCTION (USING NIGHT SET BACK FACILITY)	63
18.5	NIGHT SETBACK SCREEN	65
18.6	SERVICE MODE SCREEN	65
18.7	ERROR LOG SCREEN	65
19.0	TROUBLESHOOTING	66
19.1	CHECKING TEMPERATURE SENSORS	66
19.2	TROUBLESHOOTING CHART	66
19.3	ERROR CODES	67
20.0	ErP SPECIFICATION DATA SHEET	70
21.0	USER INSTRUCTIONS	70

1.0 INTRODUCTION

- The Lochinvar EcoShield™ range is a floor standing direct gas-fired condensing storage water heater. The equipment comprises a stainless steel mesh radial burner assembly; a heat exchanger that permits fully condensing operation, a vitreous enamel lined steel storage vessel, a Stainless Steel circulating pump and interconnecting pipework between the storage vessel and heat exchanger.
- The burner is initiated by a full electronic ignition sequence control that incorporates a spark ignition and a flame rectification device for supervision of the flame.
- The output from the water heater is regulated by a variable speed combustion fan and gas/air ratio controls to maintain the correct combustion at all levels of modulation. This configuration allows modulation down to 20% of the rated output.
- This equipment is intended for use on Group H Natural Gas (2nd Family) and LPG propane (3rd Family). The information relating to propane firing is to be found in **Section 16.0: LPG FUEL**.



This equipment MUST NOT use gas other than that for which it has been designed and adjusted.

- This equipment must be installed by a competent person, registered with a HSE approved body. All installations must conform to the relevant Gas Safety and Building Regulations. Health & Safety requirements must also be taken into account when installing any equipment. Failure to comply with the above may lead to prosecution.
- If the equipment is to be connected to an unvented (pressurised) system, care must be taken to ensure all extra safety requirements are satisfied should a high or low-pressure condition occur in the system.
- The equipment is designed for direct connection to a flue system.
- **Ancillary Options:**
 - Unvented Water System Kits SHW35-SHW61 WH19
 - Unvented Water System Kits SHW86-SHW146 WH21
 - De-stratification Pump Kit WH9
 - Condensate Neutralisation Kit KIT2000
 - Flue System Components See section 10.0

2.0 SAFETY GUIDELINES



READ AND UNDERSTAND THE INSTRUCTIONS

Read and fully understand all instructions before attempting to operate maintain or install the unit.

Keep these instructions near the water heater for quick reference.

This equipment must be installed by a competent person, registered with the H.S.E. approved body. All installations must conform to the relevant Gas Safety and Building Regulations. Health & Safety requirements must also be taken into account when installing any equipment. Failure to comply with the above may lead to prosecution

Without written approval of the manufacturer the internals of the water heater may not be changed. When changes are executed without approval, the water heater certification becomes invalid.

Commissioning, maintenance and repair must be done by a skilled installer/engineer, according to all applicable standards and regulations.

2.1 GENERAL DESCRIPTION OF SAFETY SYMBOLS USED



BANNED

A black symbol inside a red circle with a red diagonal indicates an action that should not be performed



WARNING

A black symbol added to a yellow triangle with black edges indicates danger



ACTION REQUIRED

A white symbol inserted in a blue circle indicates an action that must be taken to avoid risk



ELECTRICAL HAZARD

Observe all signs placed next to the pictogram. The symbol indicates components of the unit and actions described in this manual that could create an electrical hazard.



HOT SURFACES

The symbol indicates those components with a high surface temperature that could create a risk.



This symbol shows essential information which is not safety related



Recover or recycle material

2.2 WHAT TO DO IF YOU SMELL GAS



Warning if you smell gas

- No naked flames, no smoking!
- Avoid causing sparks, do not switch on or off electrical equipment or lights
- Open windows and doors
- Shut off the main gas supply
- Warn occupants and leave the building
- After leaving the building alert the local gas supply company
- Do not re-enter the building until it is safe to do so



Lochinvar Limited is not liable for any damage caused by inaccurately following these installation instructions. Only original parts may be used when carrying out any repair or service work.



This appliance is not intended for use by persons (including children) with reduced physical, sensory or mental capabilities, or lack of experience and knowledge, unless they have been given supervision or instruction concerning use of the appliance by a person responsible for their safety. Children **MUST** be supervised to ensure that they do not play with the appliance.

3.0 PRINCIPLE PARTS

Item No	Description of item	SHW35-245	SHW46-325	SHW61-325	SHW86-410	SHW116-410	SHW146-410	
1.	AIR PRESSURE SWITCH	PRS20016		PRS20017	PRS20001	PRS20002	PRS20022	
2.	BURNER C/W GASKET	BNR30019	BNR3426	BNR3427	BNR3428	BNR3429		
3.	BURNER CONTROL	RLY40116			RLY40117	RLY40118	RLY40117	
4.	BURNER DOOR GASKET - ROPE	GKT2452						
5.	BURNER DOOR GASKET - RUBBER	GKT2455						
6.	BURNER DOOR INSULATION	FIB2291						
	CLEAN OUT DOOR GASKET	GKT2101 NOT SHOWN ON DRAWING						
7.	HEAT EXCHANGER REAR WALL INSULATION	FIB2167						
8.	CONDENSATE TRAP	MSC20260						
	FLAME SENSE PROBE CABLE	WRE2211 NOT SHOWN ON DRAWING						
9.	FLAME SENSE PROBE C/W GASKET	PLT3022						
10.	DISPLAY PCB	RLY20120						
11.	FLUE TEMPERATURE SENSOR GROMMET	N/A			MSC2200			
12.	FAN ASSEMBLY	FAN2050	FAN2051	FAN2052	FAN2053	FAN2054	FAN2055	
13.	FAN GASKET	GKT2456	GKT2436	GKT2456	GKT2436		-	
14.	FLUE TEMPERATURE SENSOR	TST20007			TST30011			
15.	GAS VALVE ASSEMBLY	VAL30071	VAL30072	VAL30073	VAL30074	VAL30075	VAL30076	
16.	IGNITION CABLE	WRE2209						
17.	IGNITION ELECTRODE C/W GASKET	PLT3021						
18.	INLET TEMPERATURE SENSOR	TST20037						
19.	OUTLET TEMPERATURE SENSOR/HIGH LIMIT	TST20038						
20.	STEP DOWN POWER TRANSFORMER	LL100170179						
21.	PUMP	PUM20081			PUM20082		PUM20083	
22.	PUMP RELAY	RLY2610						
23.	VENTURI GASKET	GKT2443				GKT2444		
24.	MAGNESIUM ANODE	WTR2500						
25.	HEAT EXCHANGER C/W GASKETS/FITTINGS RECOMMEND LOCHINVAR FIT THIS ITEM	LL200030P	LL200031P	LL200032P	LL200033P	LL200034P	LL200035P	
26.	LOW VOLTAGE CONNECTION BOARD	LL100167623						
27.	AIR SHROUD GASKET	N/A						GKT2080

3.1.1 PRINCIPLE PARTS-USE IN CONJUNCTION WITH 3.1.2

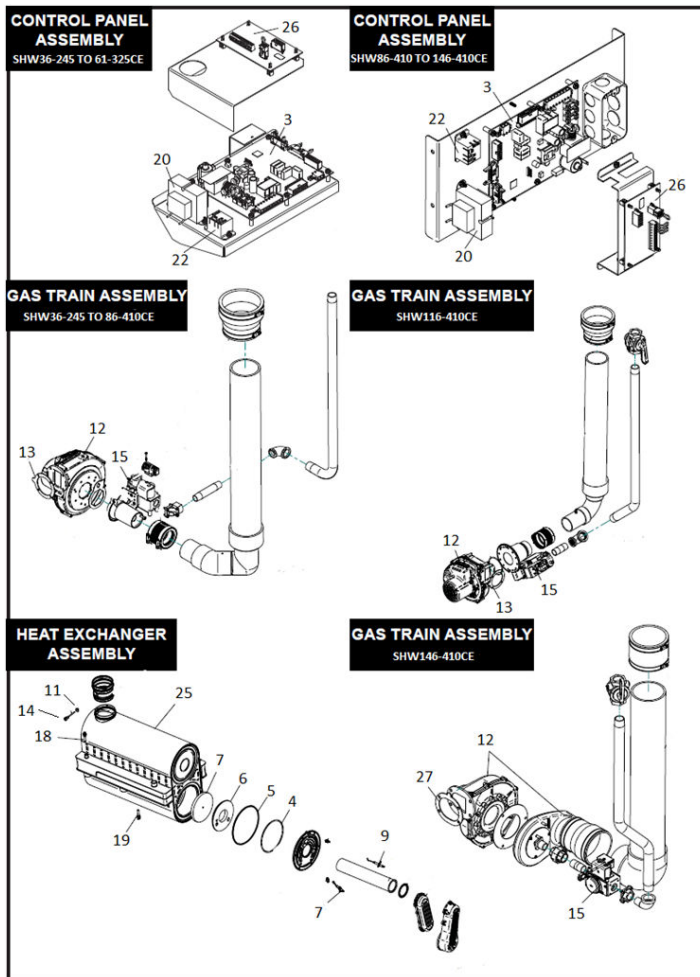
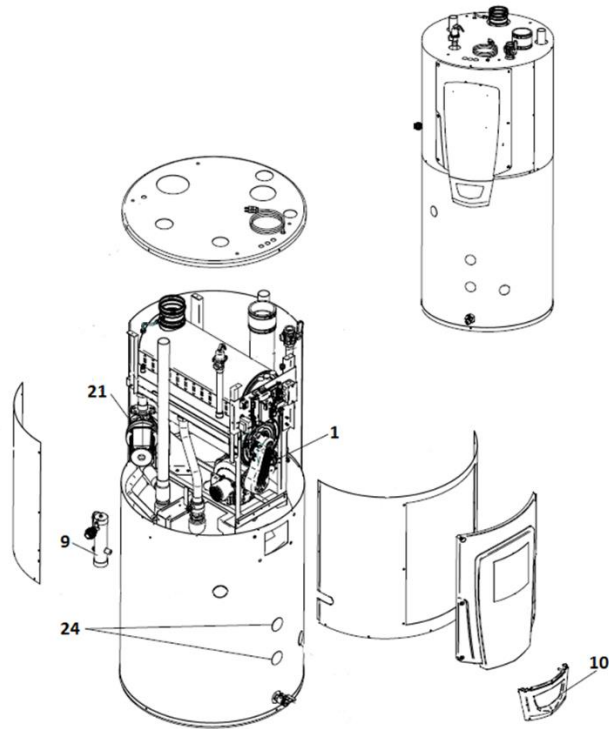

3.1.2 EXPLODED VIEW DRAWINGS

4.0 TECHNICAL DATA

Model Number		SHW35-245CE	SHW46-325CE	SHW61-325CE	SHW86-410CE	SHW116-410CE	SHW146-410CE
GENERAL DATA							
Product I.D Number		CE0063					
Category(ies)		I12H3B/P					
Countries of Destination		GB/IE					
Input (gross)	kW	36.6	44	61.5	83.5	116.9	146.5
Input (net)	kW	33.3	39.6	55.4	75.2	105.3	132
Output (P _{Min} -P _{Max})	kW	7.03-35.2	8.49-41.2	11.79-58.7	16-79.7	22.13-110.6	28.2-141.2
Recovery Rate (44°)	l/hr	695	806	1153	1567	2164	2768
Recovery Rate (50°)	l/hr	612	709	1014	1379	1904	2436
Shipping Weight	kg	136	281	290	379	388	406
Full Weight	kg	384	614	625	825	838	860
NO _x @0%O ₂ According to EU regulation 812/2013	mg/kw	25.3	33	27.3	33.1	40	38
Maximum allowable temperature of the combustion air	°C	40					
GAS DATA – G20							
Nominal gas inlet pressure	mbar	20					
Maximum gas inlet pressure	mbar	25					
Minimum gas inlet pressure	mbar	17.5					
Gas flow rate	m ³ /hr	3.5	4.2	5.7	8	11.1	14
Flue gas mass rate (@ 9.0% CO ₂)	g/sec	13.6	16	22.3	30.4	42.5	53.2
Gas inlet connection size	B.S.P	½	½	½	¾	1	1
GAS DATA – G31							
Nominal gas inlet pressure	mbar	37					
Maximum gas inlet pressure	mbar	45					
Minimum gas inlet pressure	mbar	27					
Gas flow rate	m ³ /hr	1.4	1.7	2.3	3.1	4.4	5.5
Flue gas mass rate (@ 10.5% CO ₂)	g/sec	14	16.7	23.2	31.6	44.2	55.4
Gas inlet connection size	B.S.P	R½	R½	R½	R¾	R1	R1
ELECTRICAL DATA							
Power consumption	W	361	431	459	646	932	961
Power supply		Single phase/230v/50HZ					
Protection class		IP00					
WATER DATA							
Water content	litres	248	331	332	420	423	424
Water connections (F & R)	B.S.P	1 ½			2		
Maximum water pressure	bar	10					

4.1.1 TECHNICAL DATA



The Installer must check that the information given on the data plate or supplementary plate is compatible with local supply conditions before installing the appliance.

5.0 DIMENSIONS AND CLEARANCE

5.1 DIMENSIONS

MODEL	TANK VOLUME	HEIGHT	WIDTH	T&P VALVE	COLD FEED	HOT OUTLET
		A	B	C	D	E
SHW35-245	244	1530	715	755	1610	1610
SHW46-325	325	1920	715	1117	2005	2005
SHW61-325	325	1920	715	1126	2005	2005
SHW86-410	410	1920	865	786	2020	2020
SHW116-410	410	1920	865	786	2020	2020
SHW146-410	410	1920	865	786	2020	2020

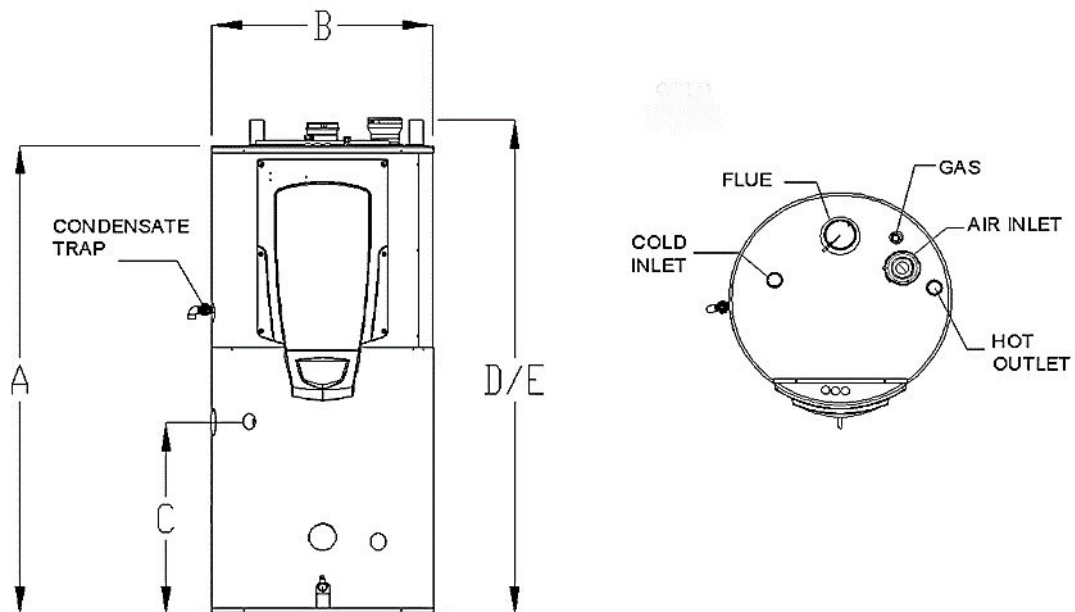

5.1.1 DIMENSIONAL DRAWING ECOSHIELD™

5.2 CLEARANCES

The location chosen for the equipment must permit the provision for a satisfactory flue system and, where necessary, an adequate air supply. The location must also provide adequate space for servicing and air circulation around each unit. This includes any electrical trunking laid across the floor and to the appliance.

RECOMMENDED SERVICE CLEARANCES:

TOP	-	450mm
LEFT	-	600mm
RIGHT	-	100mm
FRONT	-	600mm
REAR	-	ZERO
FLUE	-	25mm

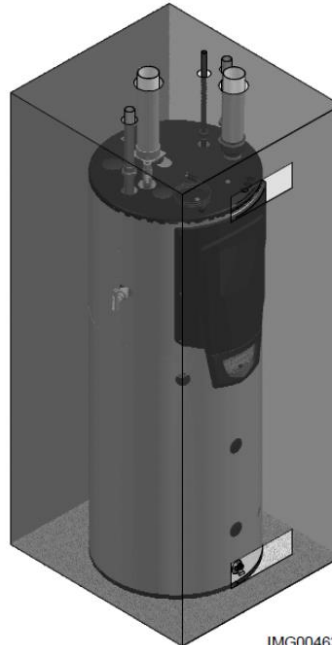

5.2.1 ENCLOSURE INSTALLATION CLEARANCES (MM)

RECOMMENDED SERVICE CLEARANCES:

TOP	-	450mm
LEFT	-	600mm
RIGHT	-	100mm
FRONT	-	600mm
REAR	-	ZERO
FLUE	-	25mm

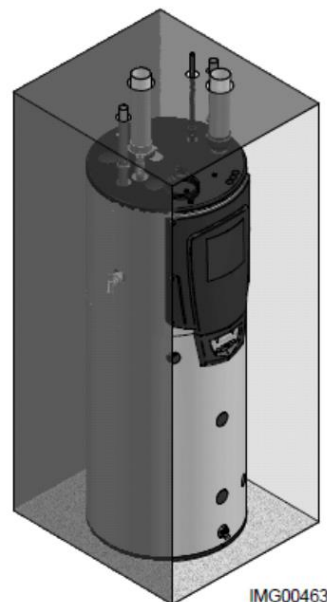

5.2.2 PLANT-ROOM INSTALLATION CLEARANCES (MM)

Further details regarding locations are given in **BS5440** or **BS6644** as appropriate.

6.0 GENERAL REQUIREMENTS

The Lochinvar EcoShield™ condensing water heater has been designed to operate trouble free for many years. These instructions should be followed closely to obtain the maximum usage and efficiency of the equipment.



READ AND UNDERSTAND THE INSTRUCTIONS



Read and fully understand all instructions before attempting to operate maintain or install the unit.

6.1 RELATED DOCUMENTS

It is law that all gas appliances are installed by competent persons, in accordance with The Gas Safety (Installation and Use) Regulations 1998. Failure to install appliances correctly could lead to prosecution. It is in your own interest, and that of safety, to ensure that this law is complied with.

The installation of the equipment **MUST** be in accordance with the relevant requirements of the Gas Safety Regulations, Building Regulations, I.E.E. Regulations and the bylaws of the local water undertaking. The installation should also be in accordance with any relevant requirements of the local gas distributor and local authority.

In addition the installation should follow the relevant guidance offered in the following documents. It is not practical to list all relevant information but emphasis is placed on the following documents, as failure to comply with the guidance given will almost certainly result in an unsatisfactory installation:

Regulation	Description
BS EN 1858: 2008 + A1: 2011	Chimneys, Components. Concrete flue blocks.
BS 5440-1: 2008	Flueing and ventilation for gas appliances of rated input not exceeding 70 kW net (1st, 2nd and 3rd family gases). Specification for installation of gas appliances to chimneys and for maintenance of chimneys.
BS 5440-2: 2009	Installation and maintenance of flues and ventilation for gas appliances of rated input not exceeding 70 kW net (1st, 2nd and 3rd family gases). Specification for installation and maintenance of ventilation for gas appliances.
BS 6644: 2011	Specification for Installation of gas-fired hot water Heaters of rated inputs between 70 kW (net) and 1.8 MW (net) (2nd and 3rd family gases).
BS EN 806 1-5	Specifications for installations inside buildings conveying water for human consumption.
BS 7671 :2008 + A3:2015	Code of practice for low temperature hot water systems of output greater than 45 kW.
BS 7074: 1989 Parts 1 and 2	Application, selection and installation of expansion vessels and ancillary equipment for sealed systems.
BS 7671: 2008 + A1: 2011	Requirements for electrical installations, I.E.E. wiring regulations seventeenth edition.
BS 7671: Amendment 2: August 2013	
BS EN 12828:2012+A1:2014	Heating systems in buildings. Design for water-based heating systems.
CP 342 (Part 2 1974):	Code of practice for centralised hot water supply-buildings other than dwellings. Institute of Gas Engineers and Managers (IGEM) Publications
IGE/UP/1 - Edition 2:	Installation pipework on industrial and commercial premises.
IGE/UP/2 – Edition 3	Gas installation pipework, boosters and compressors on industrial and commercial premises.
IGE/UP/4 - Edition 4	Commissioning of gas-fired plant on industrial and commercial premises.
IGE/UP/10 - Edition 4	Installation of flued gas appliances in industrial and commercial premises.

Gas Safety (Installation and Use) Regulations 1998

CIBSE: Guides

Part A Environmental Design

Part G Public health engineering

H.S.E. guidance

INDG 436 Safe management of industrial steam & hot water Heaters

SAFED BG01 Guidance on safe operation of Water Heaters

Third edition of the 1956 Clean Air Act Memorandum on Chimney Heights

Manufacturer's notes must not be taken in any way as overriding statutory obligations.

7.0 WATER QUALITY

Water supply quality may adversely affect the efficiency performance and longevity of Water Heaters and Hot Water systems. Hard water may cause the formation of limescale which will reduce operating efficiency and may cause early product failure. Please note the following:-

- Water Hardness – should not exceed 205ppm CaCO₃ and Total Dissolved Solids (TDS) of untreated water should not exceed 350ppm.
If these values are exceeded a water treatment specialist should be consulted. Water Softeners and Water Conditioners may be considered, but whichever method is selected, it should be suitable for installation with Direct Gas-fired Water Heaters. A maintenance regime will also be required for such systems
- High hot water temperature and high demand for hot water is likely to cause quicker limescale formation



The formation of limescale or other solids can cause a blockage within the heat exchanger, which in turn may cause premature failure. Such instances are not regarded as defects in manufacture and will not be covered under the product warranty.

8.0 LOCATION

8.1 PLANT ROOM REQUIREMENTS

The Lochinvar EcoShield™ may only be installed in a room that complies with the appropriate ventilation requirements.

The Lochinvar EcoShield™ can be used as a type C₁₃, C₃₃, or C₅₃ appliance. Due to its room sealed design, ventilation allowances for combustion air are not necessary, provided the minimum clearances and service clearances as detailed in 5.2 are observed. If the appliance is to be installed in a compartment or a hot environment, the minimum clearances detailed in 5.2.1 should be observed. In addition to this or to comply with the recommendations in **BS6644**, ventilation for cooling purposes must be fitted. For further guidance, please refer to **Section 11.0** or to **BS5440-2** or **BS6644** as appropriate.

The Lochinvar EcoShield™ can also be used as a type B₂₃ appliance. If such a configuration is to be used, then appropriate ventilation for cooling and combustion must be provided. For further details, please refer to **Section 9 AIR SUPPLY** or to **BS5440-2** or **BS6644** as appropriate.

8.2 GENERAL REQUIREMENTS

Corrosion of the heat exchanger and flue system may occur if air for combustion contains certain chemical vapours. Such corrosion may result in poor combustion and create a risk of asphyxiation. Aerosol propellants, cleaning solvents, refrigerator and air conditioning refrigerants, swimming pool chemicals, calcium and sodium chloride, waxes and process chemicals are corrosive. Products of this sort should not be stored near the water heater or outside by the air intake (if applicable). The fitting of this equipment in a situation where aerosols or other chemicals may be entrained into the combustion air will invalidate the warranty.

The equipment must be installed on a level surface that is capable of adequately supporting its weight (when filled with water) and any ancillary equipment. The operation of the equipment must not cause the temperature of any combustible material in the vicinity of the equipment and its flue to exceed 65°C. If such a situation is unavoidable, appropriate insulation should be provided.



Locate the equipment so that if the appliance or any connecting pipework should leak, water damage will not occur. When such locations cannot be avoided a suitable drain pan should be installed under the equipment. The pan should be adequately drained but must not restrict the combustion or ventilation airflow.

8.3 CONDENSATE DRAIN

The condensate drain is located on the left hand side of the water heater. It is fitted with a ½" PVC tee and union, this should be connected to an appropriate condensate drain, sloping continuously away from the water heater at an angle of at least 3° (50mm per metre).

The Water Resources Act requires that trade effluent is discharged to municipal sewers between pH 6.5 and 10.0. If it is determined that these levels cannot be achieved, an in-line condensate neutralisation kit is available from Lochinvar Limited. This unit is capable of neutralising 4000 litres of condensate to a pH of 7.0 before releasing it to a drain.

9.0 GAS SUPPLY

The Lochinvar EcoShield™ range is suitable for use on second and third family gasses 2H - G20 - 20mbar and 3P - G31 - 37mbar. Details relating to Natural Gas (2H) appear below; **for details relating to Propane (3P) please refer to Section 16.0 LPG FUEL.**

9.1 SERVICE PIPES

The local gas distributor must be consulted at the installation planning stage in order to establish the availability of an adequate supply of gas. An existing service pipe must not be used without prior consultation with the local gas distributor.

9.2 METERS

A new gas meter will be connected to the service pipe by the local gas distributor contractor. An existing gas meter should be checked, preferably by the gas distributor, to ensure that it is adequate to deal with the rate of gas supply required.

9.3 GAS SUPPLY PIPES

Supply pipes must be fitted in accordance with **IGE/UP/2**. Pipework from the meter to the equipment must be of adequate size. The complete installation must be purged and tested as described in **IGE/UP/1**. Refer to **Section 16.0 LPG Fuel** for information on LPG pipework installation guidance.

9.4 BOOSTED SUPPLIES

Where it is necessary to employ a gas pressure booster, the controls must include a low-pressure cut-off switch at the booster inlet. The local gas distributor must be consulted before a gas pressure booster is fitted. For details of how to connect a low-pressure cut-off switch, please refer to **Section 11 Electrical Supply**

9.5 PLANT-ROOM CONTROL VALVE

A manual valve for plant-room isolation must be fitted in the gas supply line. It must be clearly identified and readily accessible for operation, preferably by an exit.

9.6 EQUIPMENT GAS SYSTEM LEAK CHECK



An approved gas-inlet appliance isolating valve and union should be installed for each unit in a convenient and safe position and be clearly marked.

Ensure that the gas-inlet appliance isolating valve is in the OFF position. Although the equipment receives a gas leak check and gas train component integrity check prior to leaving the factory, transit and installation may cause disturbance to unions, fittings and components. During commissioning a further test for tightness should be carried out on the equipment gas pipework and components.



Care must be taken not to allow leak detection fluid on or near any electrical parts or connections.

10.0 FLUE SYSTEM

All versions of the EcoShield™ Condensing water heater can be installed as either type B23 (fan assisted open flue) or C13, C33, C43, C53, C63 (room sealed) appliances. Only C13, C33, C53 Flue systems are covered in any detail within this document, further information can be found in the EcoShield™ Flue assemblies and ancillaries guide available at www.lochinvar.ltd.uk See the relevant section for details of each flue type and requirements.

10.1 FLUE SYSTEM GENERAL REQUIREMENTS



Install the horizontal flue components with an angle of 3° back in the direction of the boiler (roughly equal to five centimetres for every linear meter). Failure to install the flue correctly will result in a build-up of condensate within the flue pipework that will cause early component failure.



When using a wall terminal, there is the possible risk of ice building-up on surrounding parts/structures, because the condensate will freeze. This risk should be taken into account during the design phase of the heating installation.



EcoShield™ Water heaters will produce large condensate clouds especially during cold weather, consideration must be taken as to whether this will cause a nuisance to neighbouring properties and if so alternative flue arrangements used.



EcoShield™ Water heaters can operate with very low flue temperatures; as such the flue system used must be suitable for use with condensing appliances made from either Polypropylene or stainless steel and have a temperature class of T120.



Aluminium flue pipe must not be used on this appliance as it may lead to premature failure of the heat exchanger and will invalidate the warranty.



Before installation of any flue system read the installation manual carefully for both the appliance and flue system to be used. Information on the flue system Supplied by Lochinvar can be found within this manual.

Model Number		SHW35-245CE	SHW46-325CE	SHW61-325CE	SHW86-410CE	SHW116-410CE	SHW146-410CE
FLUE DATA TYPE B₂₃							
Nominal flue diameter (d _{nom})	mm	80			100		
Nominal flue diameter (d _{outside})	mm	80 +/-0.3			100 +/-0.3		
Nominal flue diameter (d _{inside})	mm	81 +/-0.6			101 +/-0.6		
Nominal flue diameter (L _{insert})	mm	50 +20/ -2			50 +20/ -2		
Maximum flue gas temp.	°C	120					
Maximum equivalent length	m	60					
Equivalent length 90° bend	mm	1000					
Equivalent length 45° bend	mm	500					
Flue gas temperature	°C	70					
Flue draught requirements	mbar	-0.03 to -0.1					
FLUE DATA TYPE C₁₃ & C₃₃							
Nominal flue diameter	mm	80/125			100/150		
Maximum flue gas temp.	°C	120					
Maximum equivalent length	m	30					13
Equivalent length 90° bend	mm	1000					
Equivalent length 45° bend	mm	500					
FLUE DATA TYPE C₄₃ & C₅₃							
Nominal flue diameter (d _{nom})	mm	80			100		
Nominal flue diameter (d _{outside})	mm	80 +/-0.3			100 +/-0.3		
Nominal flue diameter (d _{inside})	mm	81 +/-0.6			101 +/-0.6		
Nominal flue diameter (L _{insert})	mm	50 +20/ -2			50 +20/ -2		
Minimum flue gas temp	°C	35					
Average flue gas temp	°C	70					
Maximum flue gas temp.	°C	120					
Maximum equivalent length	m	60*					
Equivalent length 90° bend	mm	1000					
Equivalent length 45° bend	mm	500					
FLUE DATA TYPE C₆₃							
Nominal flue diameter (d _{nom})	mm	80			100		
Nominal flue diameter (d _{outside})	mm	80 +/-0.3			100 +/-0.3		
Nominal flue diameter (d _{inside})	mm	81 +/-0.6			101 +/-0.6		
Nominal flue diameter (L _{insert})	mm	50 +20/ -2			50 +20/ -2		
Minimum flue gas temp	°C	35					
Average flue gas temp	°C	70					
Maximum flue gas temp.	°C	120					
Max combustion air temperature	°C	40					
Maximum equivalent length	m	48					

10.1.1 FLUE SYSTEM TECHNICAL DATA TABLE

* On twin pipe systems, the maximum equivalent length is the sum of the air inlet components and the exhaust components.

10.2 FLUE DISCHARGE

The flue system must ensure safe and efficient operation of the equipment to which it is attached, protect the combustion process from wind effects and disperse the products of combustion to open external air.

The flue must terminate in a freely exposed position and be so situated as to prevent the products of combustion entering any opening in a building. For installations with a total output above 333kW nett, the clean air act should be consulted and complied with.

Under certain operating and weather conditions, the EcoShield™ water heater may generate a plume at the terminal. Consideration should be given to the nuisance this may cause and the terminal should be sited accordingly.

For further information on terminal locations, please refer to **Section 10.3.1 FLUE TERMINAL POSITIONS.**

10.3 CONDENSATE DRAIN

If the flue system rises at an angle of at least 3° (50mm per metre), no additional condensate drain will be required. Failure to provide an adequate rise in the flue system may lead to pooling of condensate which may lead to premature failure of the flue system.

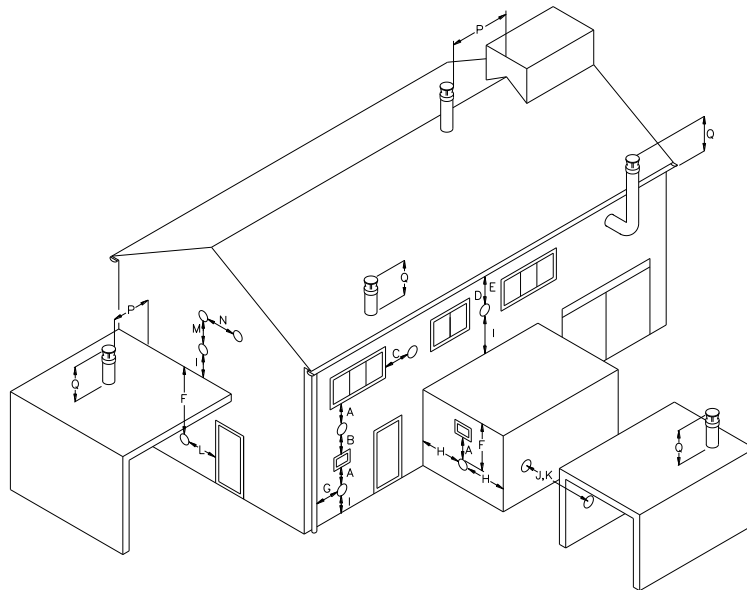

10.3.1 FLUE TERMINAL POSITIONS

Location	Description	SHW35-245CE SHW46-325CE SHW61-325CE	SHW86-410CE SHW116-410CE SHW146-410CE
A	Directly below an opening, air brick, opening windows etc.	300	2000
B	Above an opening, air brick, opening windows etc.	300	1000
C	Horizontally to an opening, air brick, opening windows etc.	300	1000
D	Below a gutter or sanitary pipework	75	75
E	Below the eaves	200	200
F	Below a balcony or car port roof	200	200
G	From a vertical drain or soil pipe	150	150
H	From an internal or external corner	300	300
I	Above ground, roof or balcony level	300	300
J	From a surface facing the terminal	600	1000
K	From a terminal facing the terminal	1200	2000
L	From an opening in the car port (e.g. door, window) into the dwelling	1200	1200
M	Vertically from a terminal on the same wall	1500	1500
N	Horizontally from a terminal on the same wall	300	600
P	From a vertical structure on the roof	300	300
Q	Above intersection with the roof	300	300

10.3.2 FLUE TERMINAL MINIMUM DISTANCES

10.4 FLUE SYSTEM GENERAL REQUIREMENTS

Detailed recommendations for the flue system are given in **BS5440-1** for equipment of rated input not exceeding 70kW net, **BS6644** for equipment above 70kW net and **IGE/UP/10** for equipment of rated input above 54kW net. The following notes are intended to give general guidance only.

10.5 APPROVED FLUE SYSTEM



For Concentric and Twin pipe flue systems only the Lochinvar supplied M&G flue system must be used



The approved flue system is not suitable for use external to the building. If external routes cannot be avoided, a flue system manufacturer should be consulted to supply a suitable alternative.

10.6 INSTALLATION PRECAUTIONS

- The approved flue system is rated to 120°C max. To prevent the exhaust temperature exceeding this, the appliance is supplied with a flue gas temperature sensor.



This must be fitted during the installation of the flue system. Failure to do so may lead to severe personal injury, death or substantial property damage.

- The water heater must not be operated unless the complete flue system is installed. This includes the water heater connections, concentric adaptor (if required) flue pipes, air ducts (if required) and terminals. If discharging at low level, a suitable flue guard must be installed.
- During assembly precaution should be taken to ensure that the internal sealing ring is seated correctly.
- Due to the close tolerances in the flue system, it may be necessary to use a twisting action to fit the joints together. No lubrication other than water should be used.

10.7 CONDENSATE DRAIN

Condensate can flow back to the appliance, this will travel through the heat exchanger into the condensate drain via the trap.

If the flue system rises at an angle of at least 3° (50mm per metre), no additional condensate drain will be required. Failure to provide an adequate rise in the flue system may lead to pooling of condensate which may lead to premature failure of the flue system.

10.8 TYPE B₂₃ CONVENTIONAL FANNED FLUE

When the heater is installed as a Type B₂₃ appliance, the flue system should be installed in accordance with the flue manufacturer's specific instructions. A kit of components is available to facilitate conventional flueing of the EcoShield™ water heater;



This must be fitted prior to any other flue pipework.

- SHW35-245CE –SHW61-325CE kit number SHCF003
- SHW86-410CE –SHW145-410CE kit number SHCF004

10.9 ROOM SEALED (TYPE C) FLUE ASSEMBLY

Before fitting the flue system for either type C13 Horizontal or C53 Vertical Concentric flue the flue transition kit should be installed to the top of the heater as per 10.9.3 and 10.9.7



SHW35-245,SHW46-325,SHW61-325



SHW86-410,SHW116-410,SHW146-410

10.9.1 ECOSHIELD™ SHOWING TRANSITION KIT FITTED

10.9.2 TRANSITION KIT SHW35-245CE – SHW61-325CE

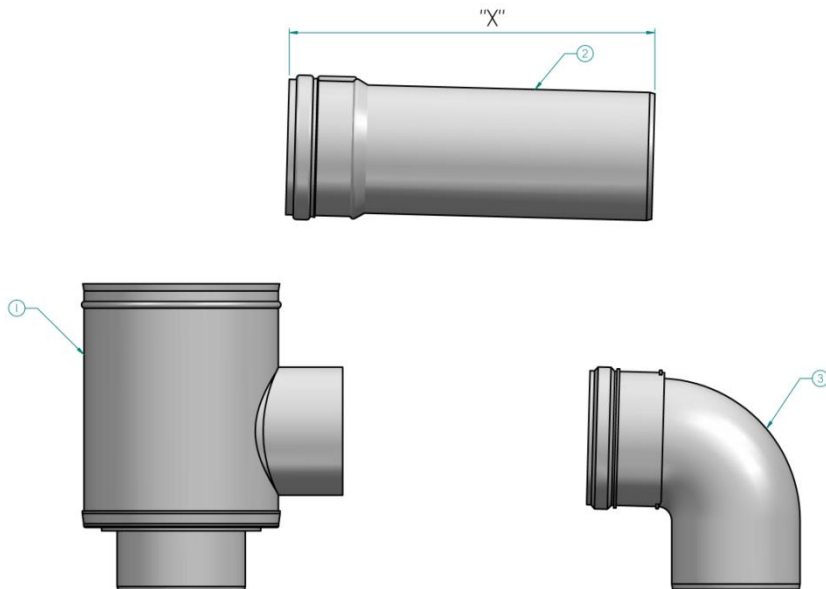

10.9.3 FLUE TRANSITION DETAILS SHW35-245CE – SHW61-325CE

ITEM	DESCRIPTION
1	CONCENTRIC ADAPTER
2	EXTENSION
3	ELBOW

10.9.4 FLUE CONNECTION DETAILS SHW35-245CE - SHW61-325CE

MODEL	"X" DIMENSION
SHW35-245 NG CE	115mm
SHW46-325 NG CE	195mm
SHW61-325 NG CE	No cut required

10.9.5 EXTENSION LENGTH SHW35-245 CE - SHW61-325 CE

To install the flue connection to the SHW35-245CE - SHW61-325CE water heaters the following procedure should be followed:

1. Insert the air intake transition into the intake connection reducer and tighten the worm drive clip.
2. Fit 80mm elbow (Item 3 in Table) to cut end of extension.
3. To the side (intake) connection of the concentric adaptor (Item 1 in Table), fit the other end of the 80mm dia. Extension.
4. Fit the bottom (flue) connection of the concentric adaptor to the flue connection on the heater.

10.9.6 TRANSITION KIT SHW86-410CE, SHW116-410CE & SHW146-410CE

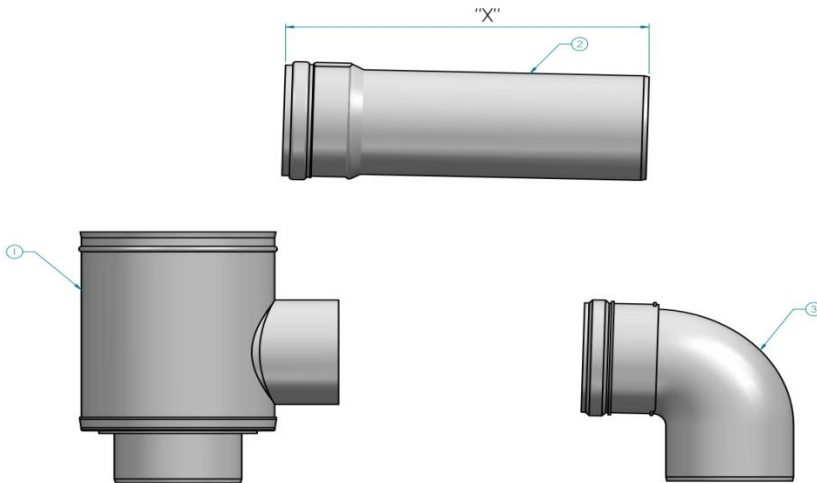

10.9.7 FLUE TRANSITION DETAILS SHW86-410CE - SHW146-410CE

ITEM	DESCRIPTION
1	CONCENTRIC ADAPTER
2	EXTENSION
3	ELBOW

10.9.8 FLUE CONNECTION DETAILS SHW86-410CE - SHW146-410CE

MODEL	"X" DIMENSION
SHW86-410 NG CE	135mm
SHW116-410 NG CE	No cut required
SHW146-410 NG CE	No cut required

To install the flue connection to the SHW86-410 CE – SHW146-410 CE water heaters the following procedure should be followed:

1. Insert the air intake transition into the intake connection reducer and tighten the worm drive clip.
2. Fit 100mm elbow (Item 3 in 10.9.7) to cut end of extension.
3. To the side (intake) connection of the concentric adaptor (Item 1 in 10.9.7), fit the other end of the 100mm dia. Extension.
4. Fit the bottom (flue) connection of the concentric adaptor to the flue connection on the heater.

10.10 C13 CONCENTRIC HORIZONTAL FLUE SYSTEMS

Flue system specifications

- MANUFACTURER MUELINK AND GROL (M&G)
- TEMPERATURE CLASS T120
- FLUE GAS MATERIAL PP

Each concentric horizontal flue kit includes the items shown in the tables below

Item No SHHF003		
CONCENTRIC HORIZONTAL FLUE ASSEMBLY MODELS SHW35-245,SHW46-325,SHW61-325		
COMPONENTS INCLUDED		
Item No.	Description	Included
M86934	CONCENTRIC HORIZONTAL TERM Ø80/125mm PP (NO WALL PLATES)	1
M28925	TERMINAL WALL PLATES (PAIR)	1
M121602	TWIN PIPE TO CONCENTRIC ADAPTOR Ø80/80mm TO Ø80/125mm PP	1
M75256	AIR INLET TRANSITION Ø80mm ALU	1
M84471	SAMPLING POINT Ø80/125mm PP	1
M84460	CONCENTRIC BEND 90° Ø80/125mm PP	1

Item No SHHF004		
CONCENTRIC HORIZONTAL FLUE ASSEMBLY MODELS SHW86-410,SHW116-410,SHW146-410		
COMPONENTS INCLUDED		
Item No.	Description	Included
LV310758	CONCENTRIC HORIZONTAL TERMINAL Ø100/150mm PP	1
M75257	AIR INLET TRANSITION Ø100mm ALU	1
M121605	TWIN PIPE TO CONCENTRIC ADAPTOR Ø100/100mm TO Ø100/150mm PP	1
M84421	SAMPLING POINT Ø100/150mm PP	1
M84412	CONCENTRIC BEND 90° Ø100/150mm PP	1

10.11 HORIZONTAL FLUE TERMINAL INSTALLATION

When the Water Heater is installed as a Type C₁₃ (Horizontal concentric) appliance, the flue system should be installed as follows:

1. Determine the location of the flue terminal, taking into account minimum distances as detailed in 10.3.1 and the relevant British Standards.
2. Taking care to protect the appliance from debris and dust, drill a hole in the desired location. The diameter of the hole should be no more than 10mm greater than the diameter of the air supply pipe of the terminal.
3. Determine the required length of the terminal and cut as necessary.



When determining the required length for the flue terminal, the outer wall plate or rosette should be flush to the wall. (see 10.11.1)



Once cut; remove all burrs and sharp edges

4. Insert the terminal into the drilled hole. The terminal section should be installed level or with a fall to outside (Max. 10mm per metre) to prevent the ingress of water.



When inserting the terminal, ensure the air intake section is at the bottom.

5. Fill the void between the terminal and wall with water resistant sealant.
6. Fit the wall plates or rosette using appropriate fixings.
7. Install the remainder of the flue system working progressively away from the Water Heater supporting the pipes as necessary.

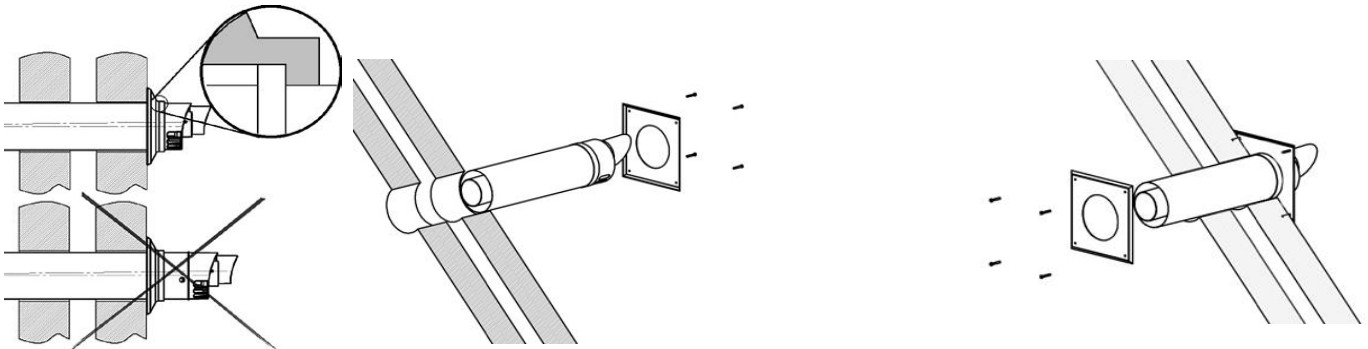

10.11.1 HORIZONTAL TERMINAL INSTALLATION

10.12 FLUE TERMINAL GUARDING

If a horizontal flue terminal is to be fitted less than 2 metres from ground level or in a location where it can be touched from a window, door or balcony, a terminal guard must be fitted.

10.13 C33 CONCENTRIC VERTICAL FLUE SYSTEMS

Flue system specifications

- MANUFACTURER MUELINK AND GROL (M&G)
- TEMPERATURE CLASS T120
- FLUE GAS MATERIAL PP

Each concentric Vertical flue kit includes the items shown in the tables below

Item No SHVF003		
CONCENTRIC VERTICAL FLUE ASSEMBLY MODELS SHW35-245,SHW46-325,SHW61-325		
COMPONENTS INCLUDED		
Item No.	Description	Included
M75256	AIR INLET TRANSITION Ø80mm ALU	1
M121602	TWIN PIPE TO CONCENTRIC ADAPTOR Ø80/80mm TO Ø80/125mm PP	1
M84471	SAMPLING POINT Ø80/125mm PP	1
M86864	CONCENTRIC VERTICAL TERMINAL Ø80/125mm PP	1

Item No SHVF004		
CONCENTRIC HORIZONTAL FLUE ASSEMBLY MODELS SHW86-410,SHW116-410,SHW146-410		
COMPONENTS INCLUDED		
Item No.	Description	Included
M75257	AIR INLET TRANSITION Ø100mm ALU	1
M121605	TWIN PIPE TO CONCENTRIC ADAPTOR Ø100/100mm TO Ø100/150mm PP	1
M84421	SAMPLING POINT Ø100/150mm PP	1
LV310754	CONCENTRIC VERTICAL TERMINAL Ø100/150mm PP	1

10.14 VERTICAL FLUE TERMINAL INSTALLATION

When the water heater is installed as a Type C33 appliance, the flue system should be installed as follows:

1. Confirm that the roof flashing is correct for the type of roof through which the terminal is to be installed. **Section 10.14.1**
2. Determine the desired location for the flue terminal, taking into account minimum distances as detailed in **Section 10.3.1 TERMINAL POSITIONS** and the relevant British Standards.
3. Taking care to protect the appliance from debris and dust, drill a hole in the desired location. The diameter of the hole should be no more than 10mm greater than the diameter of the air supply pipe of the terminal.



The hole should be drilled from the outside to ensure that no damage is done to the roofing material. Extra care should be taken to ensure that the hole is drilled vertically.

4. Install the roof flashing and secure as appropriate.
5. Carefully insert the roof terminal through the roof flashing and hole in the roof.



When inserting the roof terminal do not support or turn the terminal using the cap.

6. Ensure the terminal is vertical using a spirit level.
7. Fit the support bracket around the terminal and secure using appropriate fixings. Do not tighten the support bracket
8. Install the remainder of the flue system working progressively away from the water heater supporting the pipes as necessary.
9. Once the flue system is fully installed, tighten the clamp to secure the terminal in place.

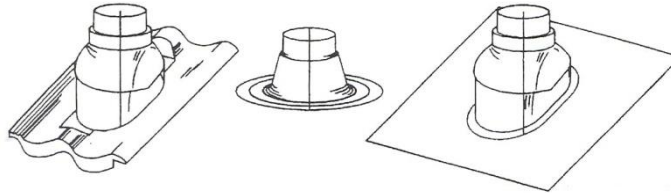

10.14.1 VERTICAL TERMINAL ROOF FLASHINGS FOR SYNTHETIC, FLAT AND TILED ROOFS

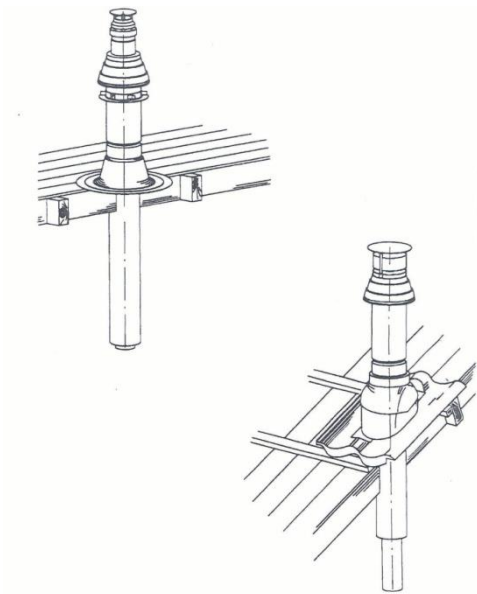

10.14.2 INSTALLING TERMINAL THROUGH ROOF FLASHING

10.14.3 GENERAL CONCENTRIC FLUE SYSTEM INSTALLATION GUIDELINES



The information in this section is for General guidance only and may not fully represent the installation on site

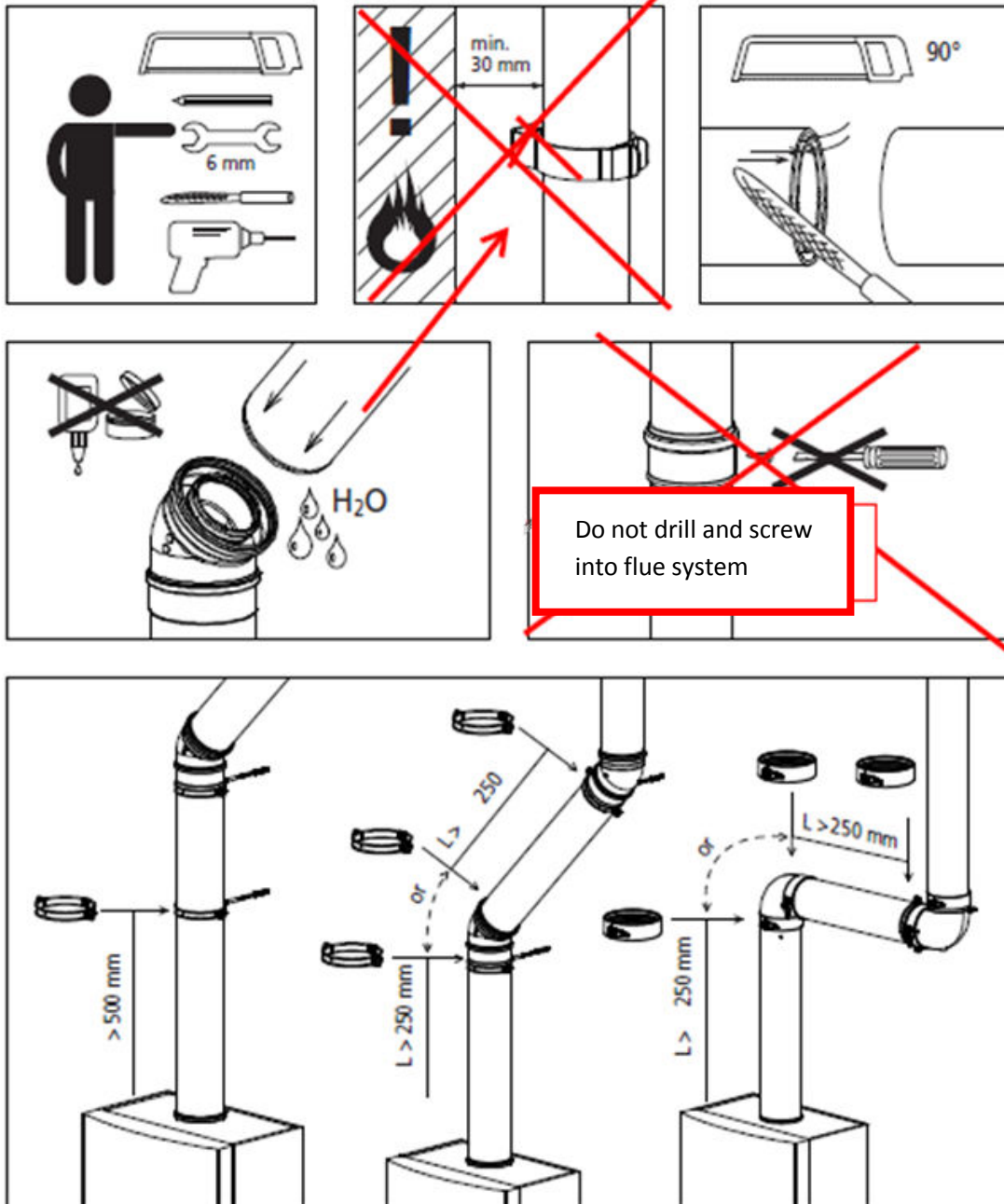

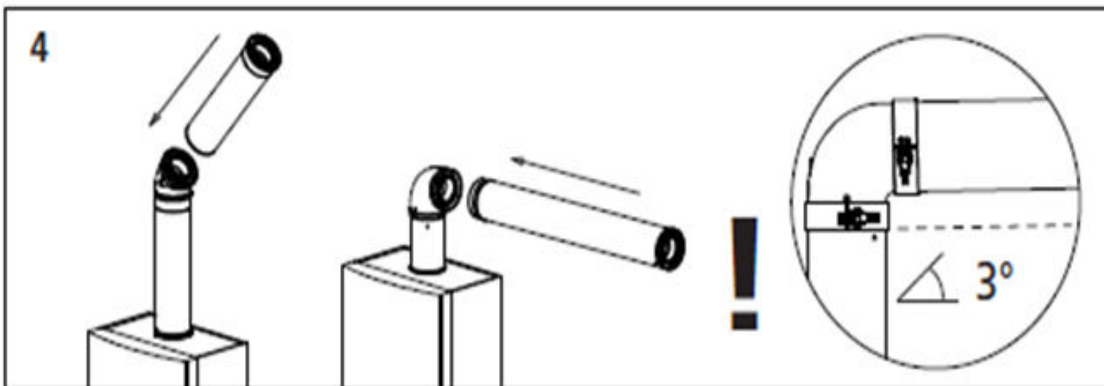
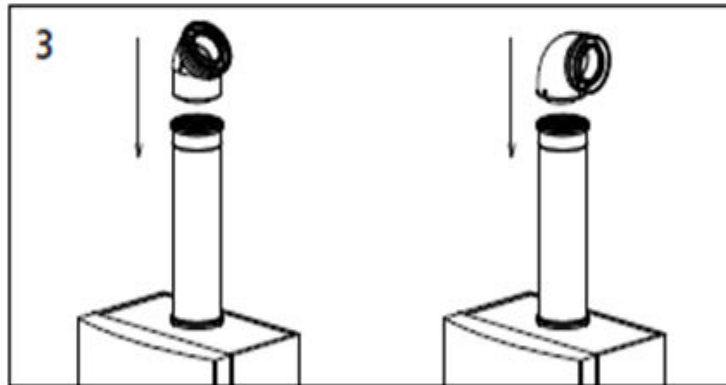
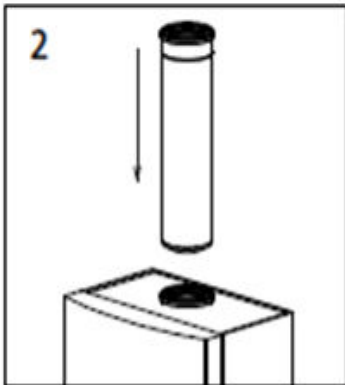
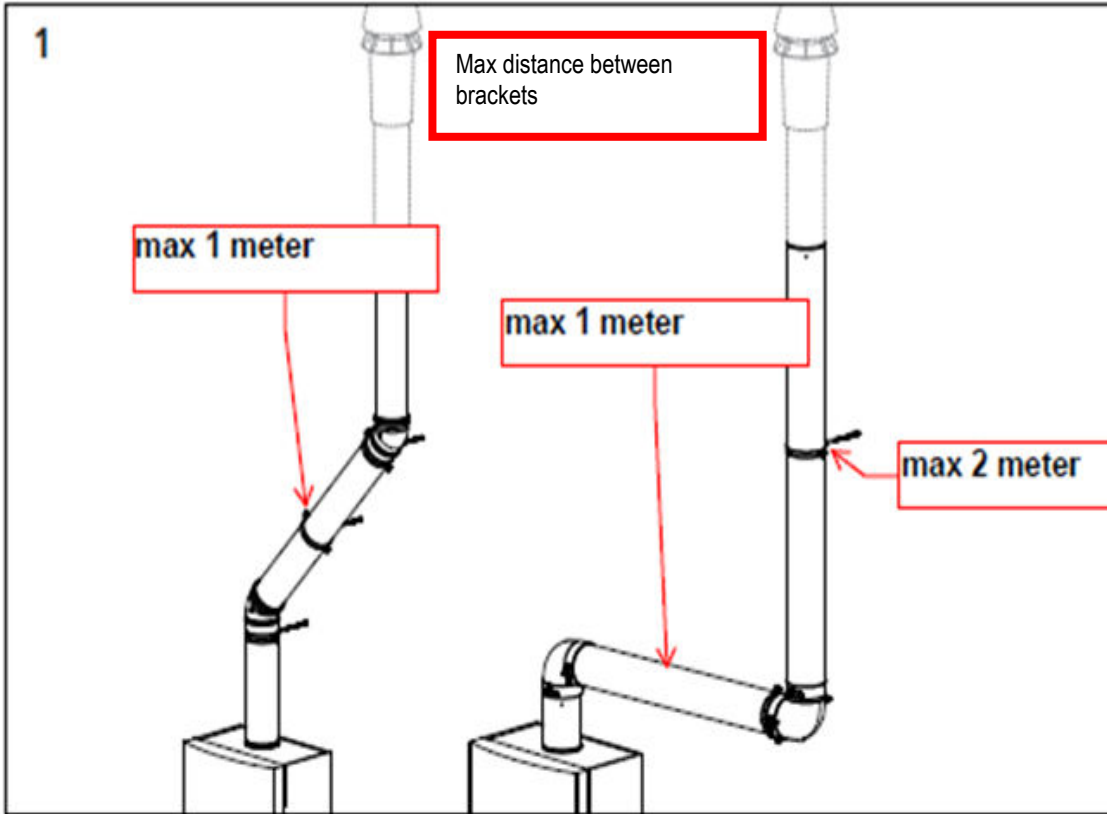

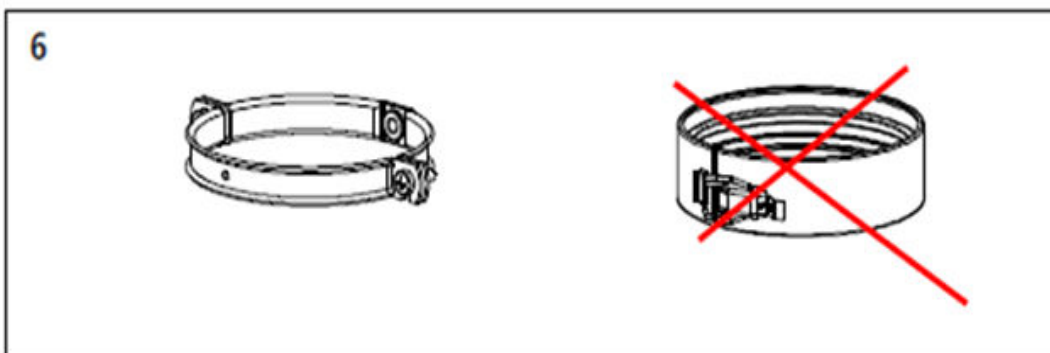
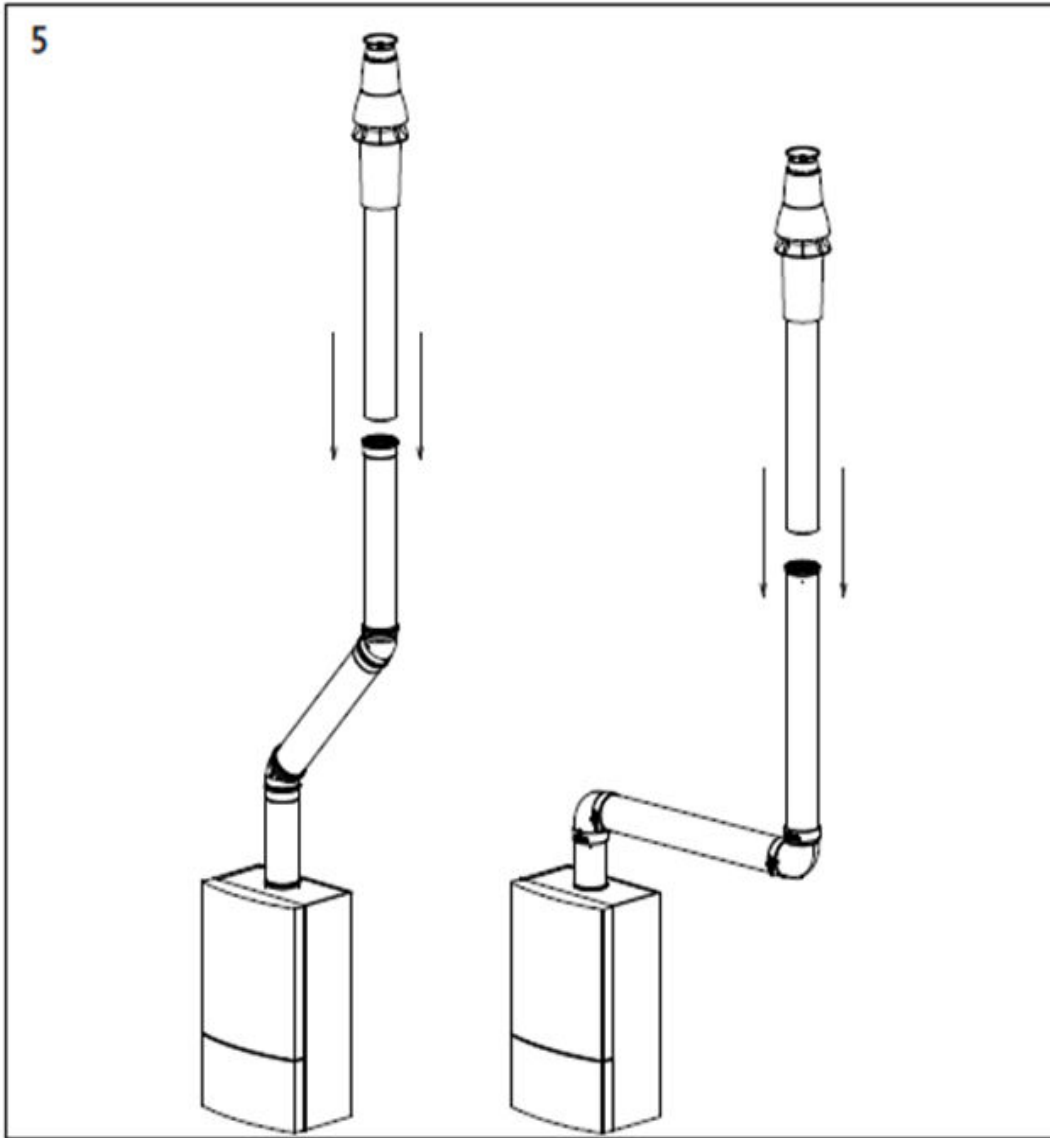

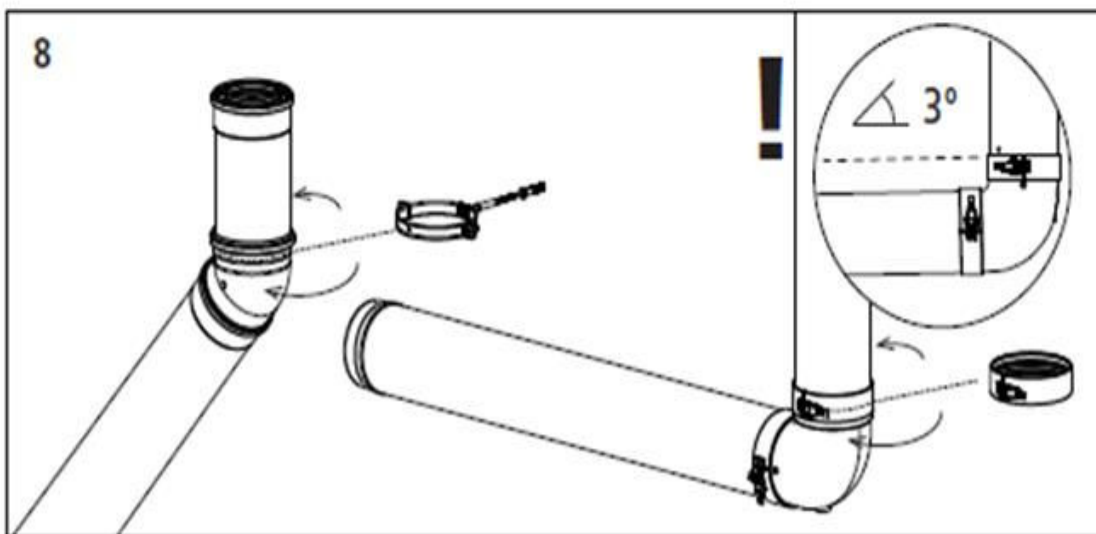
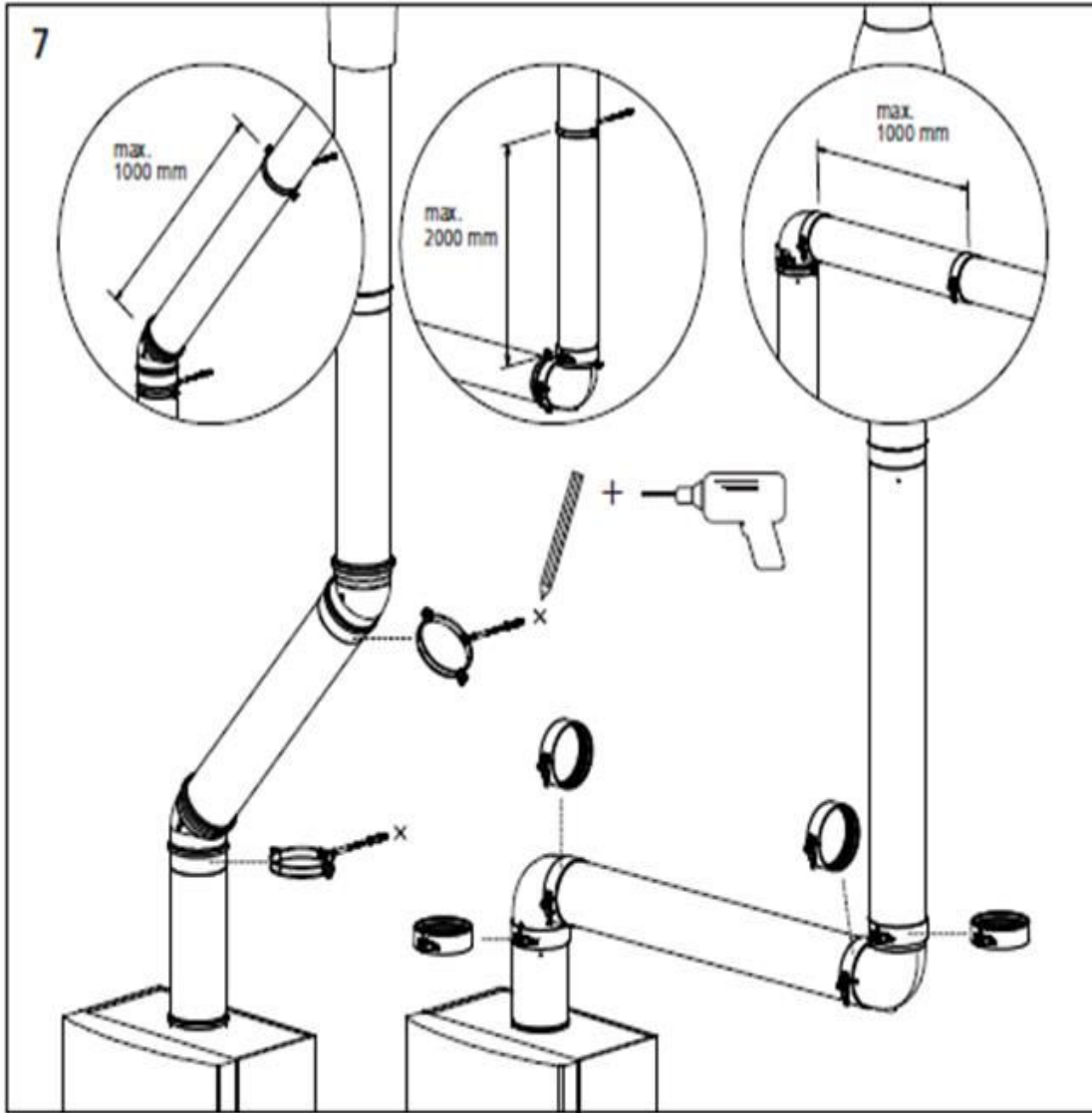

10.15 C₄₃ COMMON VENTED FLUE SYSTEMS IN MULTI FLOOR BUILDINGS

In C₄₃ systems water heaters are fitted on common air inlet and flue gas outlet (either concentric or parallel) systems in multiple floor buildings.



Only use a C₄₃ venting system when the common duct is a natural draught chimney. The common duct is part of the building, not a part of the system.

10.15.1 CONDENSATE DRAIN

Condensate can flow back to the appliance, this will travel through the heat exchanger into the condensate drain via the trap.

If the flue system rises at an angle of at least 3° (50mm per metre), no additional condensate drain will be required. Failure to provide an adequate rise in the flue system may lead to pooling of condensate which may lead to premature failure of the flue system.

10.16 C₅₃ (TWIN PIPE) FLUE SYSTEMS

Flue system specifications

- MANUFACTURER MUELINK AND GROL (M&G)
- TEMPERATURE CLASS T120
- FLUE GAS MATERIAL PP

Each Twin-Pipe starter assembly includes the items shown in the tables below, you then add either the Vertical or Horizontal terminal and air inlet.

Item No SHTF003		
TWIN-PIPE FLUE STARTER ASSEMBLY		MODELS
SHW35-245,SHW46-325,SHW61-325		
COMPONENTS INCLUDED WITHIN KIT TO START INSTALLATION		
Item No.	Description	Included
M75256	AIR INLET TRANSITION Ø80mm ALU	1
M85279	SAMPLING POINT Ø80mm PP	1
VERTICAL FLUE		
M86864	CONCENTRIC VERTICAL TERMINAL Ø80/125mm PP	
LV305016	HORIZONTAL AIR INLET Ø80mm	
HORIZONTAL FLUE		
M86934	CONCENTRIC HORIZONTAL TERMINAL Ø80/125mm PP (NO WALL PLATES)	
LV305016	HORIZONTAL AIR INLET Ø80mm	
M28925	TERMINAL WALL PLATES (PAIR)	

Item No SHTF004		
TWIN-PIPE FLUE STARTER ASSEMBLY		MODELS
SHW86-410,SHW116-410,SHW146-410		
COMPONENTS INCLUDED WITHIN KIT TO START INSTALLATION		
Item No.	Description	Included
M75257	AIR INLET TRANSITION Ø100mm ALU	1
M85189	SAMPLING POINT Ø100mm PP	1
VERTICAL FLUE		
LV310754	CONCENTRIC VERTICAL TERMINAL Ø100/150mm PP	
LV305039	HORIZONTAL AIR INLET Ø100mm ALU	
HORIZONTAL FLUE		
M86934	CONCENTRIC HORIZONTAL TERMINAL Ø80/125mm PP (NO WALL PLATES)	
LV305039	HORIZONTAL AIR INLET Ø100mm ALU	
M28925	TERMINAL WALL PLATES (PAIR)	

When installing EcoShield™ on a C₅₃ twin pipe flue system, the Lochinvar Twin pipe flue starter assembly must be fitted first.



When installing the water heater as a Type C53 appliance, it should be noted that the terminals must not be installed on opposite sides of the building.



If the flue temperature sensor is not fitted, the flue gas temperature may exceed the maximum temperature rating of the flue and can lead to severe personal injury, death or substantial property damage.

To install a Type C₅₃ terminal or air inlet, the procedure for either a Type C₁₃ (horizontal) or a Type C₃₃ (vertical) terminal should be followed noting that the annular space of the terminal should be sealed off.

10.16.1 GENERAL TWIN-PIPE INSTALLATION GUIDELINES



The information in this section is for General guidance only and may not fully represent the installation on site

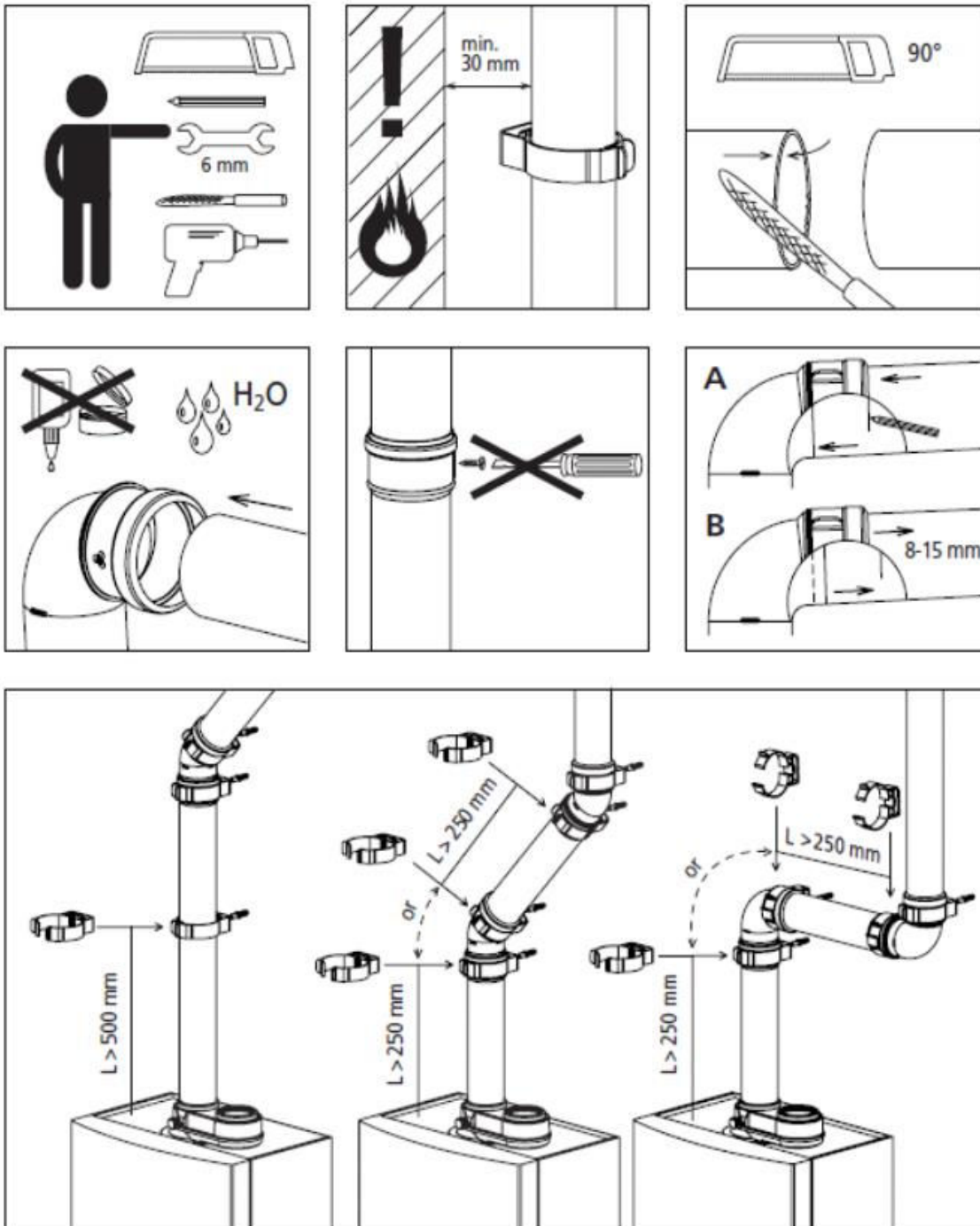

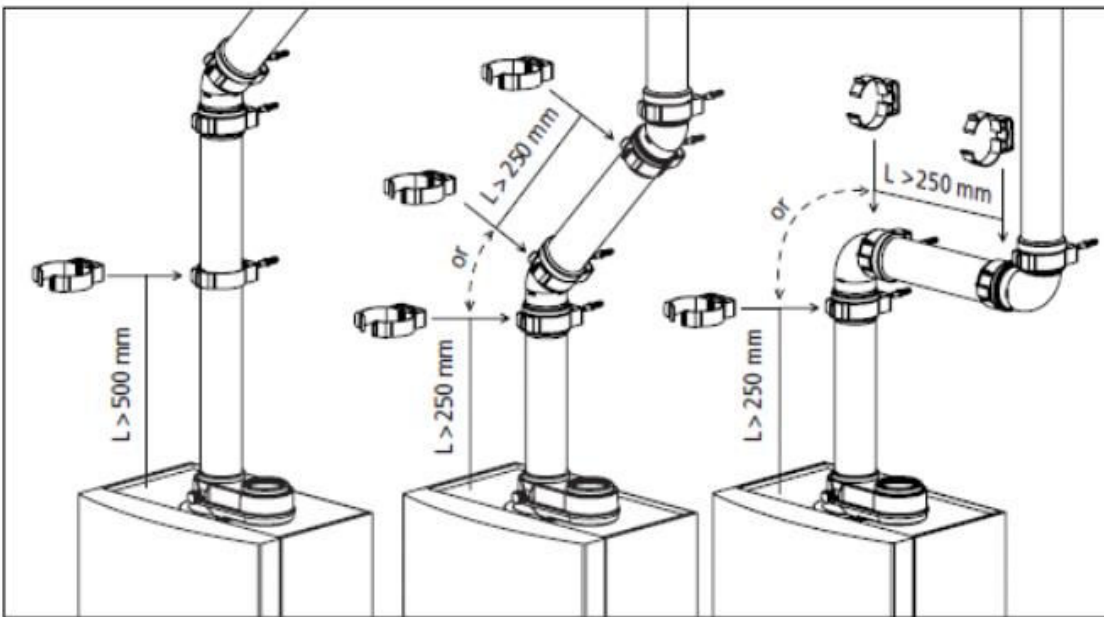
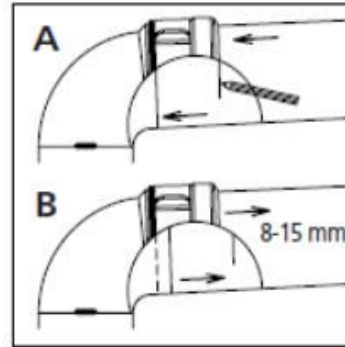
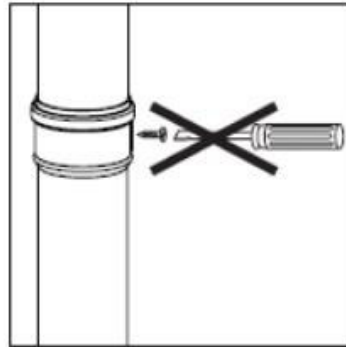
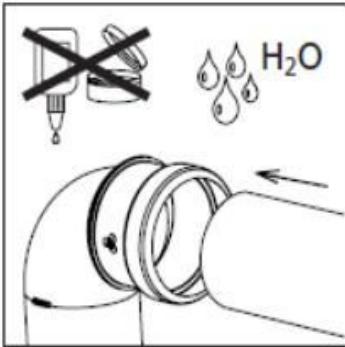
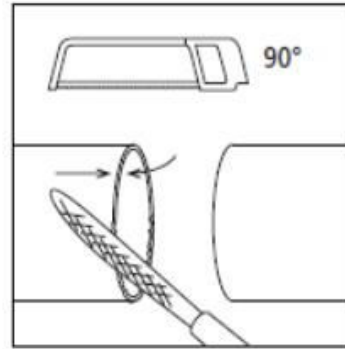
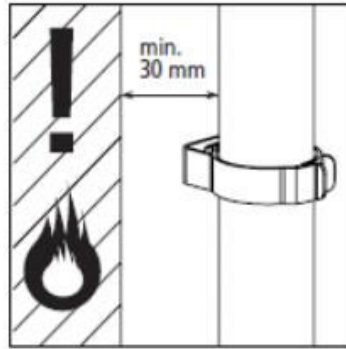
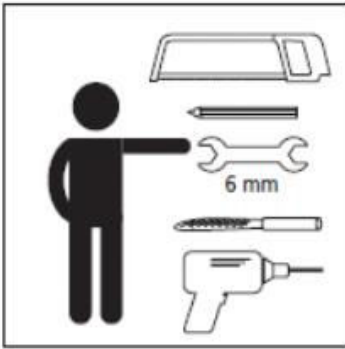

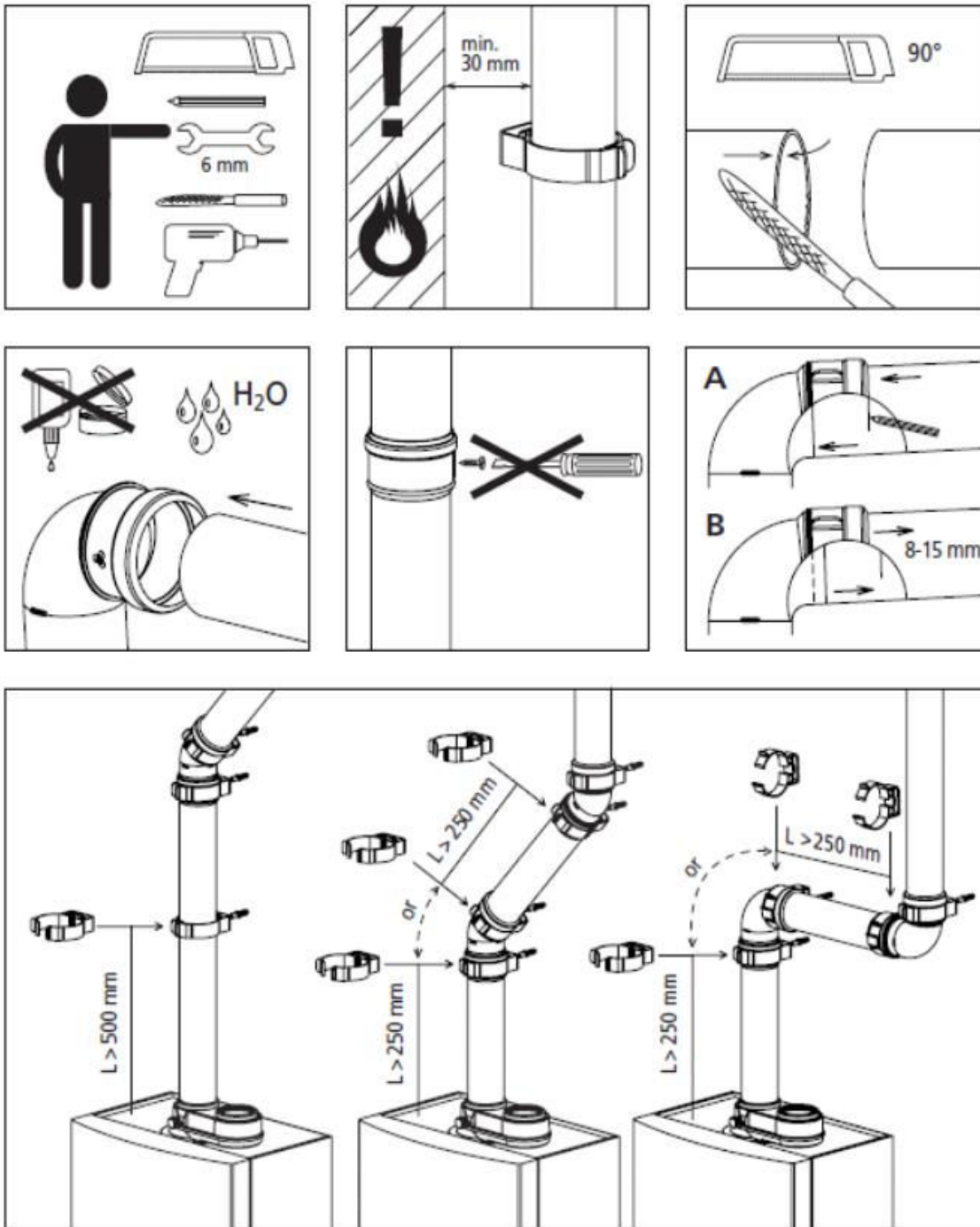

10.17 FLUE TERMINAL GUARDING

If a horizontal flue terminal is to be fitted less than 2 metres from ground level or in a location where it can be touched from a window, door or balcony, a terminal guard must be fitted.

The terminal guard is constructed from plastic-coated mild steel and is suitable for use on condensing appliances only. The guard should be installed centrally around the terminal ensuring a gap of at least 50mm between the guard and terminal is maintained.

10.18 TYPE B₂₃ (CONVENTIONAL FLUE WITH FAN ASSISTANCE)

Item No SHCF003		
CONVENTIONAL FLUE ASSEMBLY MODELS SHW35-245,SHW46-325,SHW61-325		
COMPONENTS REQUIRED TO START INSTALLATION		
Item No.	Description	Included
M75256	AIR INLET TRANSITION Ø80mm ALU	1
M73039	AIR INLET GRILLE Ø80mm ALU	1
M85279	SAMPLING POINT Ø80mm PP	1

Item No SHCF004		
CONVENTIONAL FLUE ASSEMBLY MODELS SHW86-410,SHW116-410,SHW146-410		
COMPONENTS REQUIRED TO START INSTALLATION		
Item No.	Description	Included
M75257	AIR INLET TRANSITION Ø100mm ALU	1
M86787	APPLIANCE AIR INLET GUARD Ø100mm	1
M85189	SAMPLING POINT Ø100mm PP	1

The above is a kit of components to facilitate conventional flueing of the appliance and must be fitted prior to fitting any other flue components.

10.19 C63 CERTIFIED FLUE SYSTEMS

In general, Water heaters are certified with their own purpose supplied Concentric or Twin Pipe flue systems, C63 certified appliances allow the installer to use other flue systems when installing the Water heater however, they must be of a suitable minimum standard as per Table below.

CE string flue gas material	European standard	Temperature class	Pressure class	Resistance to condensate	Corrosion resistance class	Metal: liner specifications	Soot fire resistance class	Distance to combustible material	Plastics: location	Plastics: fire behaviour	Plastics: enclosure
Min required PP	EN 14471	T120	P1	W	1		O	30	I of E	C/E	L
Min required Inox	EN 1856-1	T120	P1	W	1	L20040	O	40			

10.19.1 C63 FLUE SYSTEM SPECIFICATION

Twin-pipe Flue Systems					
Material	Water heater	d _{nom}	D _{outside}	d _{inside}	L _{insert}
PP	SHW35-SHW61	80	80 +/-0.3	81 +/-0.6	50 +20/ -2
PP	SHW86-SHW146	100	100 +/-0.3	101 +/-0.6	50 +20/ -2
Concentric Flue Systems					
Material	Water heater	d _{nom}	D _{outside}	d _{inside}	L _{insert}
PP	SHW35-SHW61	80/100	80 +/-0.3-124 +0.5/-1	81 +/-0.6-125.5 +1/-0.5	56 +/-3
PP	SHW86-SHW146	100/150	100 +/-0.3 - 148.5 +0.5/-1	101 +/-0.5 - 150 +1/-0.5	50 +20/ -2



When installing the water heater as a Type C63 appliance, it should be noted that the terminals must not be installed on opposite sides of the building.



The maximum allowable recirculation rate is 10% under wind conditions



Aluminium flue pipe must not be used on this appliance as it may lead to premature failure of the heat exchanger and will invalidate the warranty.

10.19.2 CONDENSATE DRAIN

Condensate can flow back to the appliance, this will travel through the heat exchanger into the condensate drain via the trap. If the flue system rises at an angle of at least 3° (50mm per metre), no additional condensate drain will be required. Failure to provide an adequate rise in the flue system may lead to pooling of condensate which may lead to premature failure of the flue system.

Model Number	SHW35-245CE	SHW46-325CE	SHW61-325CE	SHW86-410CE	SHW116-410CE	SHW146-410CE	
FLUE DATA TYPE C63 WITH TWIN-PIPE FLUE							
Minimum flue gas temp	°C					35	
Average flue gas temp	°C					70	
Maximum flue gas temp	°C					120	
Maximum equivalent length	m					48	
Model Number	SHW35-245CE	SHW46-325CE	SHW61-325CE	SHW86-410CE	SHW116-410CE	SHW146-410CE	
FLUE DATA TYPE C63 WITH CONCENTRIC FLUE							
Minimum flue gas temp	°C					35	
Average flue gas temp	°C					70	
Maximum flue gas temp	°C					120	
Maximum equivalent length	m					24	10

11.0 AIR SUPPLY

The following information is based on single water heater installations only. If more than one water heater is being used, **BS6644** should be consulted to calculate the necessary requirements.

11.1 COMBUSTION VENTILATION

When used as a Type C appliance, provided sufficient clearance is provided, ventilation for combustion is not necessary as the combustion air is ducted directly from outside.

When used as a Type B appliance, the combustion air requirements are as follows:

Model	Gross Input (kW)	Net Input (kW)	Ventilation (Room) (cm ²)	Compartment		Compartment	
				(Direct to Outside)		(To Internal Space)	
				High (cm ²)	Low (cm ²)	High (cm ²)	Low (cm ²)
SHW35-245CE	36.6	33.3	132	166	332	332	664
SHW46-325CE	43.9	39.6	165	200	400	400	800
SHW61-325CE	58.6	52.8	230	265	530	530	1060

11.1.1 COMBUSTION VENTILATION REQUIREMENTS SHW35-245CE – SHW61-325CE

Model	Gross Input (kW)	Net Input (kW)	Plant Room						Enclosure					
			Low Summer Use		Medium Summer Use		High Summer Use		Low Summer Use		Medium Summer Use		High Summer Use	
			High (cm ²)	Low (cm ²)	High (cm ²)	Low (cm ²)	High (cm ²)	Low (cm ²)	High (cm ²)	Low (cm ²)	High (cm ²)	Low (cm ²)	High (cm ²)	Low (cm ²)
SHW86-410CE	83.5	75.3	152	304	228	380	304	456	380	760	456	836	532	912
SHW116-410CE	117.2	105.6	212	424	318	530	424	636	530	1060	636	1166	742	1272
SHW146-410CE	146.5	132.0	264	528	396	660	528	792	660	1320	792	1452	924	1584

11.1.2 COMBUSTION VENTILATION REQUIREMENTS SHW86-410CE – SHW146-410CE

11.2 COOLING VENTILATION

When used as a type C appliance, cooling ventilation should be provided as follows:

Model	Input (Gross) kW	Input (Net) kW	Enclosure/Compartment		Enclosure/Compartment		Internal Space/Boiler Room	
			(Direct to Outside)		(To Internal Space)		High (cm ²)	Low (cm ²)
			High (cm ²)	Low (cm ²)	High (cm ²)	Low (cm ²)		
SHW35-245CE	36.6	33.2	166	166	332	332	N/A	N/A
SHW46-325CE	43.9	39.6	200	200	400	400	N/A	N/A
SHW61-325CE	58.6	52.8	265	265	530	530	N/A	N/A
SHW86-410CE	83.5	75.3	380	380	760	760	152	152
SHW116-410CE	117.2	105.6	530	530	1060	1060	212	212
SHW146-410CE	146.5	132.0	660	660	1320	1320	264	264

11.2.1 COOLING VENTILATION REQUIREMENTS

When used as a type B appliance, provision for cooling ventilation is included in the combustion ventilation allowance.

12.0 WATER CONNECTIONS

12.1 GENERAL

Recommendations for the water circulation system are given in **BS6644** and **CP 342**. The following notes are of particular importance.

1. Circulating pipework not forming part of the useful heating surface should be insulated. Cisterns, expansion vessels and pipework situated in areas exposed to freezing conditions should also be insulated.
2. Drain valves must be located in accessible positions that will permit draining of the entire system including the unit and any additional storage vessel.
3. Tapping sizes for connection to the water system are detailed in **4.1.1 Technical Data**
4. Ideally, individual valves should be fitted to each unit to enable isolation from the system. The arrangement must comply with the requirements of **BS6644**.
5. Typical pipework schematics are available from Lochinvar Limited upon request.

12.2 OPEN VENTED SYSTEM ARRANGEMENT

The Lochinvar EcoShield™ can be used in an open vented arrangement provided that a vent pipe in accordance with **CP 342**, **BS6644** or **BS6700** as appropriate is fitted. The minimum static head requirement for an open vented system is 1.0 bar.

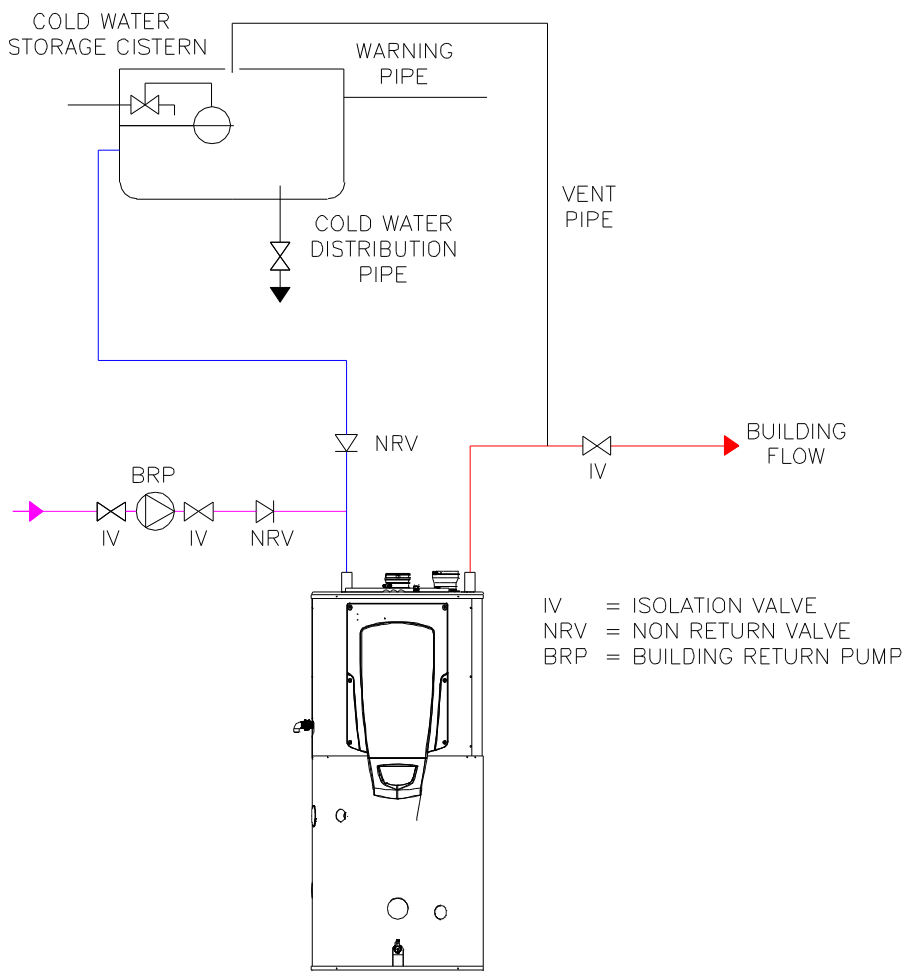

12.2.1 OPEN VENTED SYSTEM INSTALLATION SCHEMATIC

12.3 UNVENTED SYSTEM ARRANGEMENT



It is the law that unvented hot water systems be installed by an approved installer.

If the Lochinvar EcoShield™ is to be used in an unvented arrangement, the system should follow the guidance given in **BS6700** and must comply with the **Building Regulations 1992: Part G3, in England and Wales, P5 in Northern Ireland and P3 in Scotland**. A kit of components that have been suitably sized for the unvented operation of the appliance is available from Lochinvar Limited. For further information, contact Lochinvar Limited.

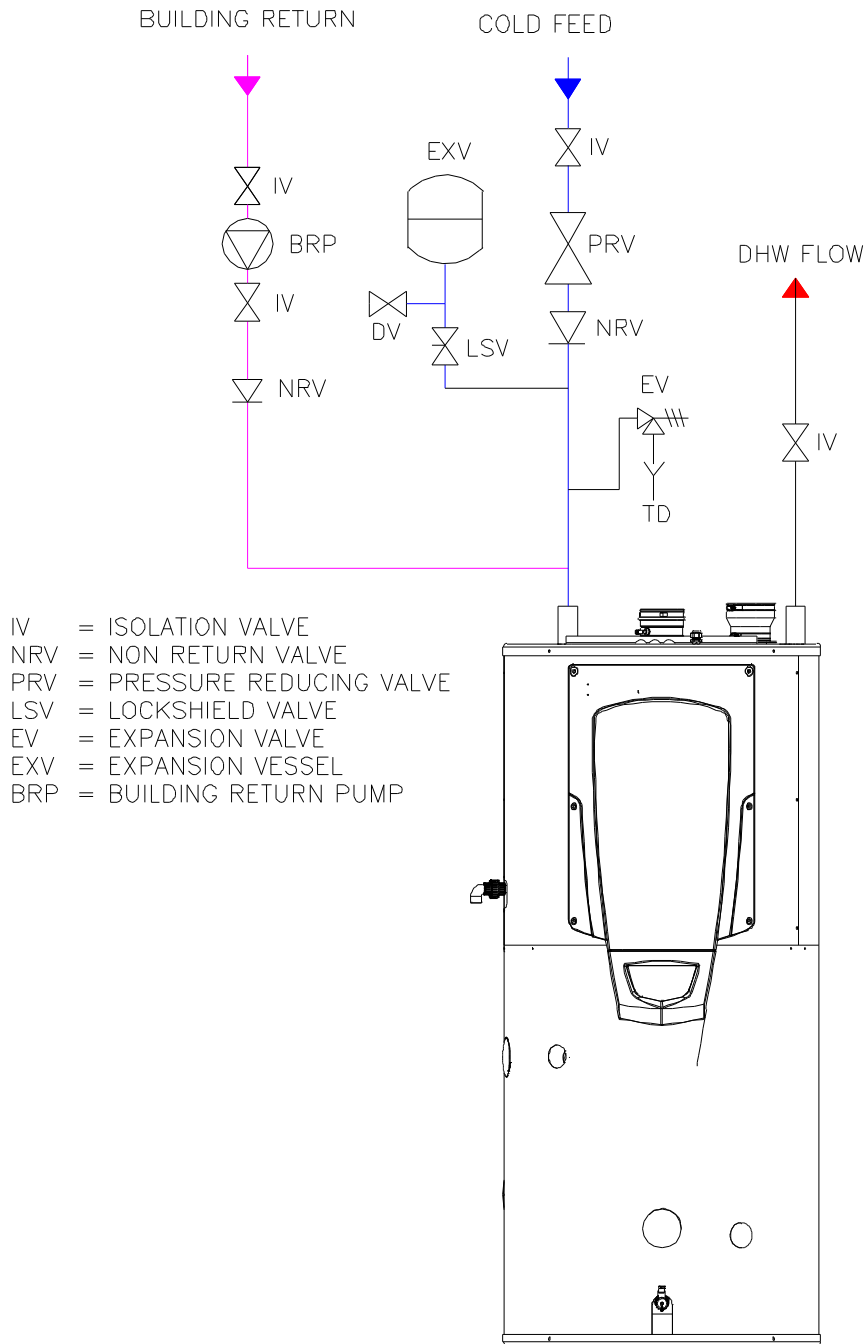

12.3.1 UN-VENTED SYSTEM INSTALLATION SCHEMATIC

12.3.2 TEMPERATURE AND PRESSURE RELIEF VALVE

A temperature and pressure relief valve is factory fitted as part of the unvented water system kit. This valve has a lift pressure of 7 bar and a lift temperature of 90°C.



This should be checked for transit damage prior to filling the water heater.



The storage vessel relief valve connection should not be used for any other purpose.

12.3.3 RELIEF VALVE DISCHARGE PIPEWORK

It is important that any discharge water does not collect in the discharge pipe-work and can run freely to the tundish. The tundish should be mounted in a vertical and visible position located in the same space as the unvented hot water storage system and be fitted as close as possible and within 500mm of the safety device e.g. the temperature relief valve.

The discharge pipe from the tundish should terminate in a safe place where there is no risk to persons in the vicinity of the discharge, be of metal and:

- a) Be at least one pipe size larger than the nominal outlet size of the safety device unless its total equivalent hydraulic resistance exceeds that of a straight pipe 9m long i.e. discharge pipes between 9m and 18m equivalent resistance length should be at least two sizes larger than the nominal outlet size of the safety device, between 18 and 27m at least 3 sizes larger, and so on. Bends must be taken into account in calculating the flow resistance.

An alternative approach for sizing discharge pipes would be to follow BS6700 Specification for design installation, testing and maintenance of services supplying water for domestic use within buildings and their curtilages.

- b) Have a vertical section of pipe at least 300mm long, below the tundish before any elbows or bends in the pipework.
- c) Be installed with a continuous fall.
- d) Have discharges visible at both the tundish and the final point of discharge but where this is not possible or is practically difficult there should be clear visibility at one or other of these locations.

Examples of acceptable discharge arrangements are:

- I. Ideally below the fixed grating and above the water seal in a trapped gully.
- II. Downward discharges at a low level; i.e. up to 100mm above external surfaces such as car parks, hard standings, grassed areas etc. are acceptable providing that where children play or otherwise come into contact with discharges, a wire cage or similar guard is positioned to prevent contact whilst maintaining visibility.
- III. Discharges at a high level; e.g. into a metal hopper and metal down pipe with the end of the discharge pipe clearly visible (tundish visible or not) or onto a roof capable of withstanding high temperature discharges of water and 3m from any plastic guttering systems that would collect such discharges (tundish visible).
- IV. Where a single pipe serves a number of discharges, such as in blocks of flats, the number served should be limited to not more than 6 systems so that any installation can be traced reasonably easily. The single common discharge pipe should be at least one pipe size larger than the largest individual discharge pipe to be connected. If unvented hot water storage systems are installed where discharges from safety devices may not be apparent i.e. in dwellings occupied by blind, infirm or disabled people, consideration should be given to the installation of an electronically operated device to warn when discharge takes place.

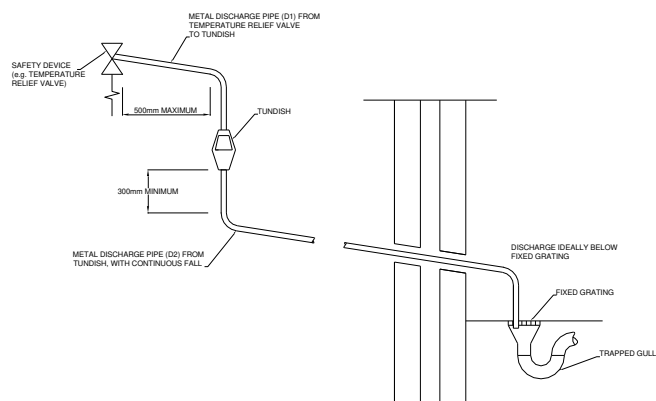

12.3.4 RELIEF VALVE DISCHARGE PIPEWORK

12.3.5 EXPANSION VESSEL SIZING

The WH19/WH21 unvented kit supplied with the EcoShield™ water heater includes an expansion vessel, this should be checked by the installer to ensure there is sufficient spare capacity available for the Hot water secondary system volume. If not an additional correctly sized expansion vessel should be installed, additional expansion vessels are available from Lochinvar Ltd.

EcoShield™	Unvented kit required	Expansion vessel supplied	Spare system expansion available
SHW35-245	WH19	V25	415litre
SHW46-325 SHW61-325	WH19	V25	338litre
SHW86-410 TO SHW146-410	WH21	V34	502litre

12.3.6 STANDARD UNVENTED SYSTEM KIT EXPANSION VESSELS

The following information is based on an inlet pressure of 3.5 bar and an expansion vessel efficiency of 0.45 using a standard 6 bar unvented kit. If the system will have different parameters a more detailed calculation will need to be made.

$$V V = \frac{S V * e}{0.45}$$

Where:

- V V = Vessel Volume
 S V = System Volume
 e = Coefficient of Expansion (See Table 10.1)

Stored Temp. °C	30	35	40	45	50	55	60
e	0.005	0.006	0.008	0.010	0.012	0.015	0.017
Stored Temp. °C	65	70	75	80	82	85	90
e	0.020	0.023	0.026	0.030	0.031	0.033	0.037

12.3.7 COEFFICIENT OF EXPANSION OF WATER AT 3.5 BAR INLET PRESSURE

13.0 ELECTRICAL SUPPLY

Wiring external to the equipment must be installed in accordance with I.E.E. Regulations and any local regulations that apply.

Model	Normal Supply Voltage	External Fuse Rating	Power Consumption
SHW35-245CE	230V AC 50 Hz 1 PH	10 Amps	361W
SHW46-325CE			431 W
SHW61-325CE			459 W
SHW86-410CE			646 W
SHW116-410CE			932 W
SHW146-410CE			961 W

13.1.1 ELECTRICAL SUPPLY REQUIREMENTS



Warning: this appliance must be earthed



A suitably competent person must check wiring. Normal supply required is 230 volts' AC, single phase, 50 hz. An isolator with a contact separation of at least 3mm in all poles should be sited close to the equipment and must only serve that equipment. The double pole switch must be readily accessible under all conditions

13.2 EXTERNAL CONTROLS

EcoShield™ is compatible with the following control and safety systems:

- Auxiliary safety system proving switch (e.g. fan dilution system proving switch)

In addition to this, EcoShield™ can give the following signals:

- Volt-free “burner on” (runtime) signal
- Volt-free “lock-out” (alarm) signal
- 24VAC auxiliary device enable signal (e.g. to start fan dilution system)

13.2.1 REMOTE ENABLING

When remote control of an EcoShield™ water heater is required and controlled using a Building Management System (B.M.S.) the factory fitted ENABLE terminals wiring sensor should be interrupted using a suitable relay.

13.3 MAINS POWER SUPPLY

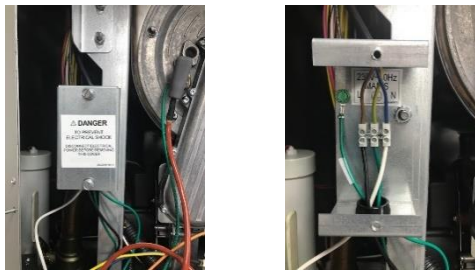

13.3.1 MAINS POWER SUPPLY TERMINAL

CONNECTION	NOTES
MAINS	Connections for a 230V ~ 1 ph 50Hz power supply.

13.3.2 MAINS POWER SUPPLY TERMINAL DETAILS

13.4 LOW VOLTAGE CONNECTOR STRIP

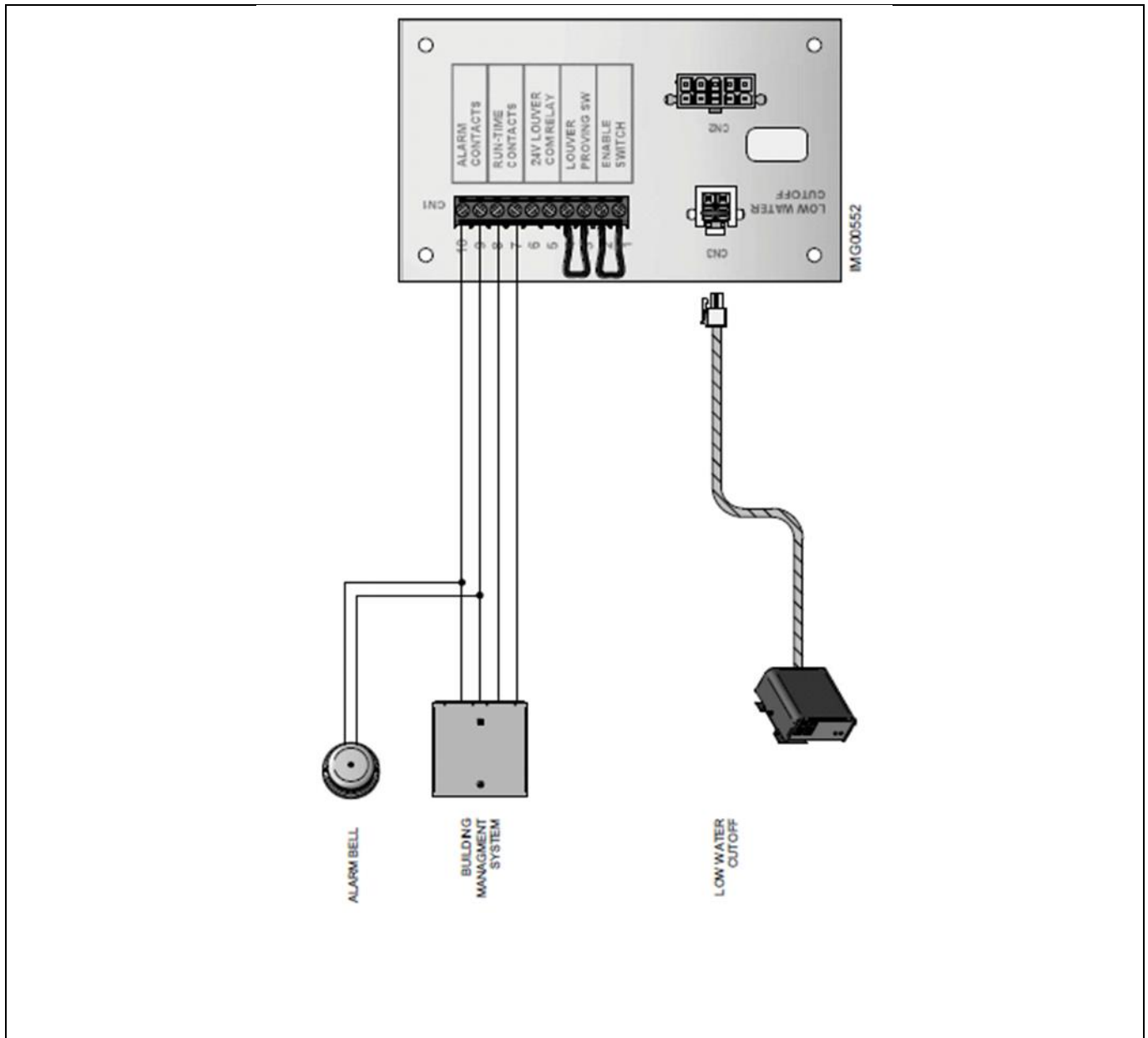

13.4.1 LOW VOLTAGE CONNECTION STRIP

PIN	CONNECTION	NOTES
1-2	EXTERNAL CONTROL	These connections should be used to enable the heater via a BMS on/off input.
3-4	SPARE EXTERNAL CONTROL	This can be used to prevent the unit firing until a fan dilution system or other external control has proved
5-6	24V COM RELAY	Can be used to supply an enable signal to an external control such as a fan dilution system
7-8	RUNTIME CONTACTS	An internal volt free contact across pins 7 & 8 will close in the event of the burner operating. This connection can be used by a BMS to monitor the operation of the heater.
9-10	ALARM CONTACTS	An internal volt free contact across pins 9 & 10 will close in the event of the heater locking out. This connection can be used by a BMS to monitor the operation of the heater.

13.4.2 LOW VOLTAGE CONNECTION TERMINAL DETAILS

13.5 ELECTRICAL CONNECTIONS

Cable routing to the High Voltage and Low Voltage Connection Strips can be achieved by removing the appropriate knockouts on the top panel of the heater. All connections should be secured using an appropriate cord anchorage. One cord anchor is supplied with the heater for securing the mains supply to the unit. If additional controls and ancillaries are to be used, the appropriate knockout should be removed and an anchor such as RS Components part number 607-897 plus locking nut 444-3085 should be fitted.



If a knockout is removed by mistake, the resulting hole must be blocked with an appropriate anchor, plug or grommet to prevent accidental access to the live parts within the water heater.

13.6 FUSES

The EcoShield™ has three internal fuses. F1 will automatically reset, F2 – F3 are slow blow fuses, located and rated as follows:

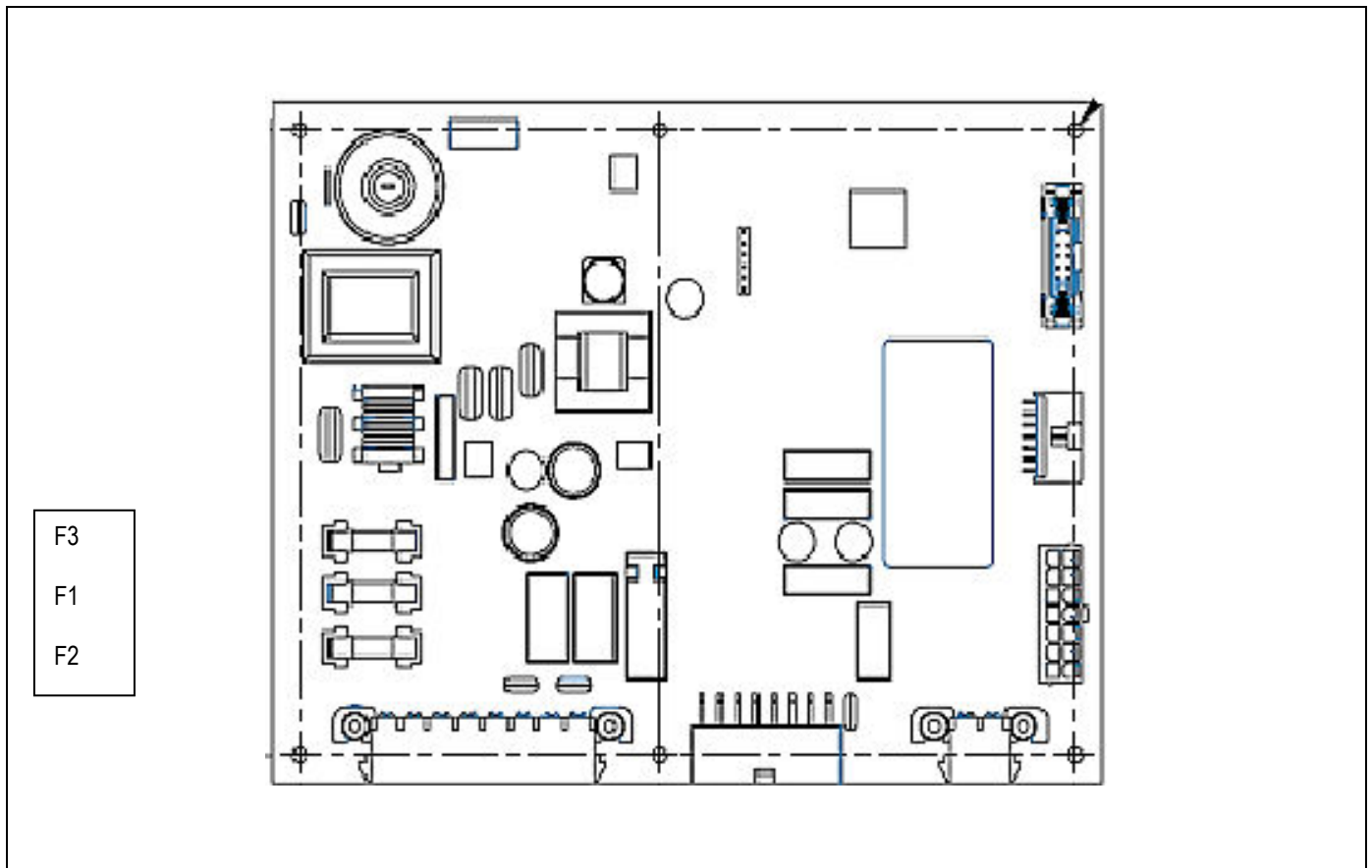

13.6.1 FUSE RATINGS AND LOCATIONS

The water heater has three spare fuses in a plastic bag attached to the control module cover. Only replace with an equivalent rated fuse. Use of non-equivalent fuses or link wires will invalidate the warranty.

- F1 5 A
- F2 3.15A
- F3 1.25A

13.7 ARC WELDING PRECAUTIONS

The appliance must be isolated from the mains electricity supply in the event of electric arc welding being carried out on any connecting pipework.

13.8 WIRING DIAGRAM

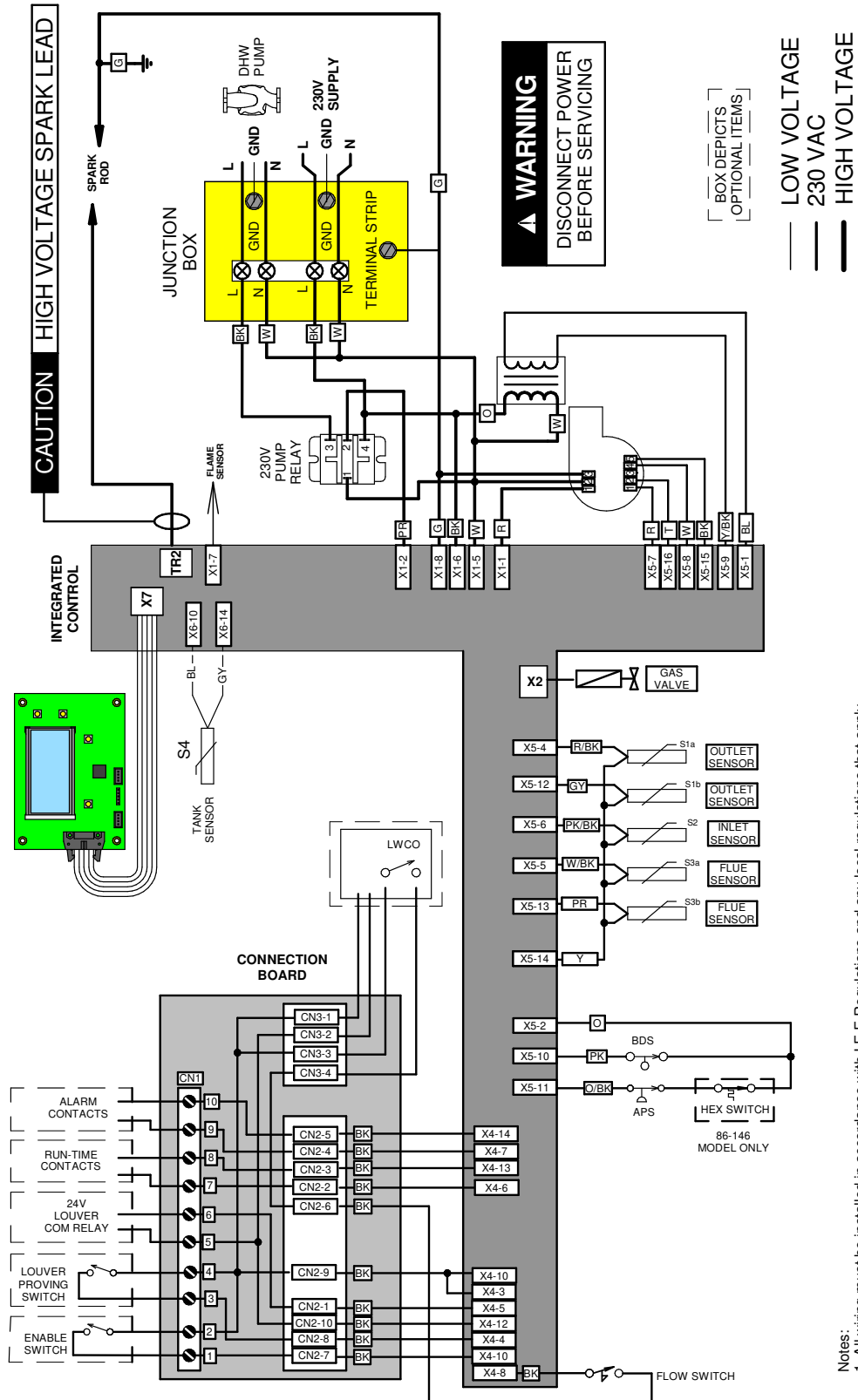

WIRING DIAGRAM LBL20352 REV A

13.8.1 WIRING DIAGRAM

13.9 LADDER DIAGRAM

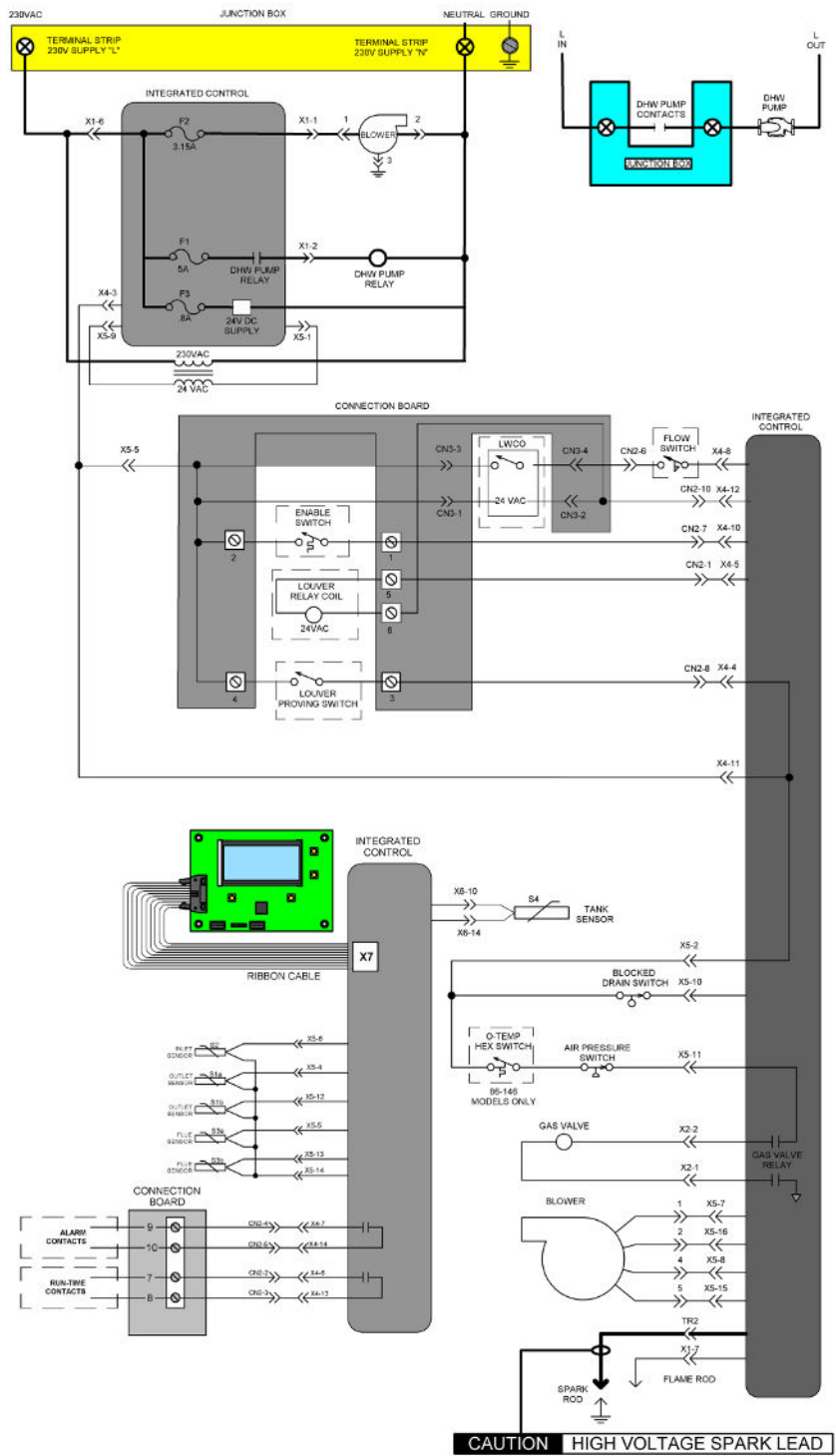

NOTES:
 1. Where possible, switches are shown without utilities (gas, water or electricity) connected to the unit. As such, actual switch states may vary from those shown on diagrams depending upon whether utilities are connected or a fault condition is present.
 2. See wiring diagram for additional notes.

⚠ WARNING
 DISCONNECT POWER BEFORE SERVICING

BOX DEPICTS OPTIONAL ITEMS

— LOW VOLTAGE
 — 230 VAC
 — HIGH VOLTAGE

LADDER DIAGRAM
 LBL29433 REV 1

13.9.1 LADDER DIAGRAM

14.0 USER CONTROL INTERFACE

14.1 GENERAL



The EcoShield™ user control interface gives information on set-up, system status and diagnostic data.

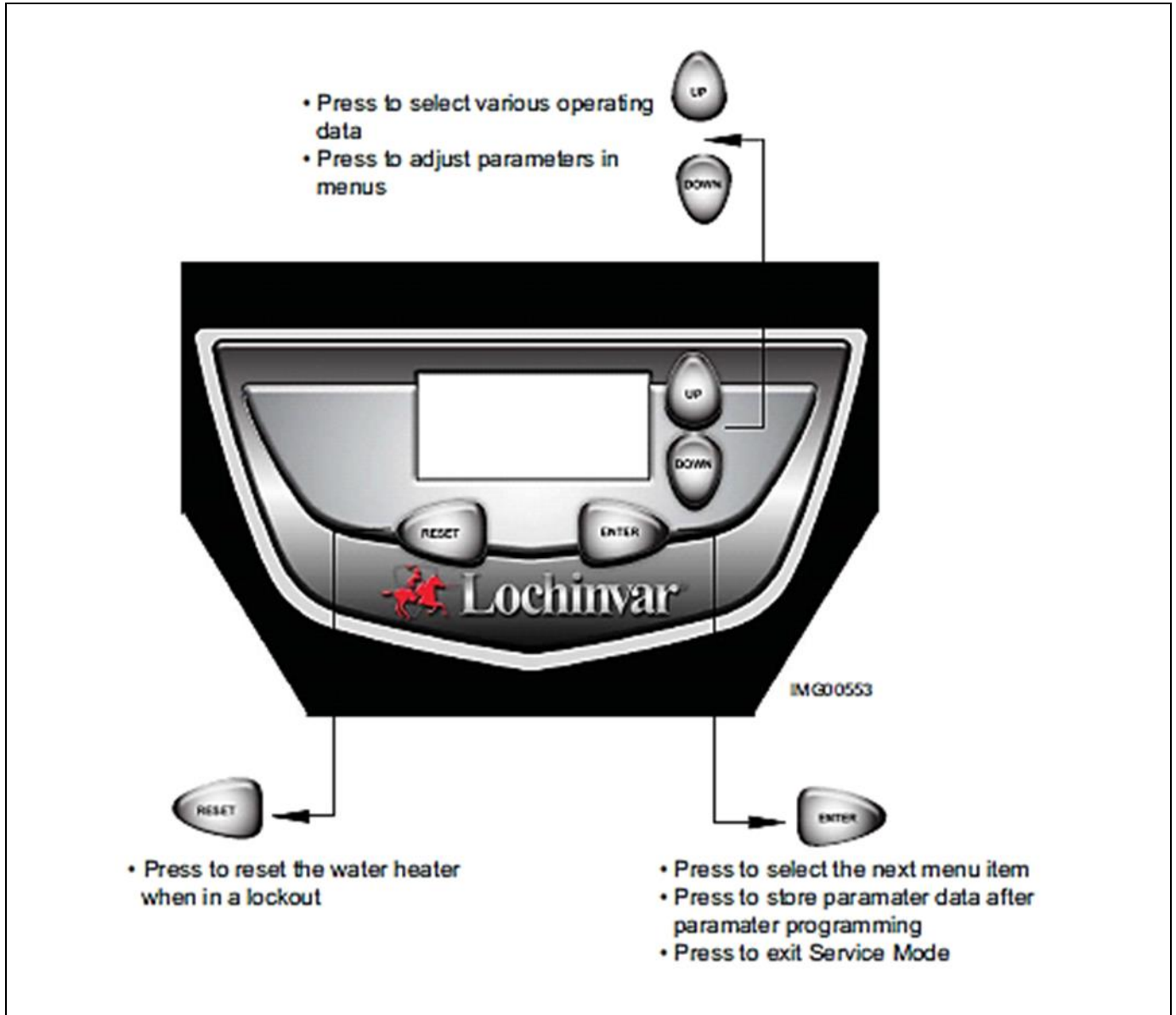

14.2 USER CONTROL INTERFACE PANEL

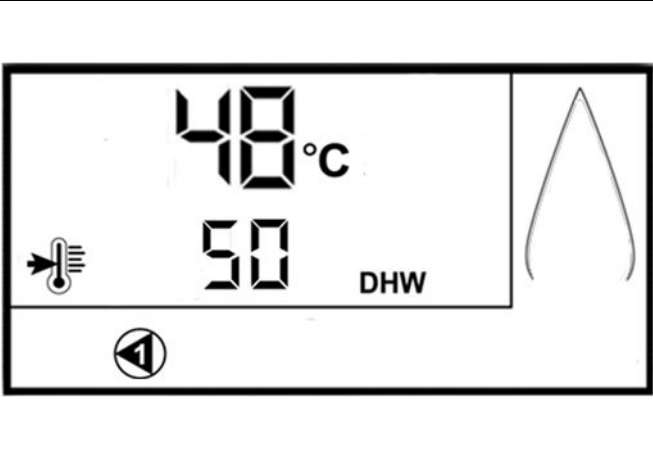
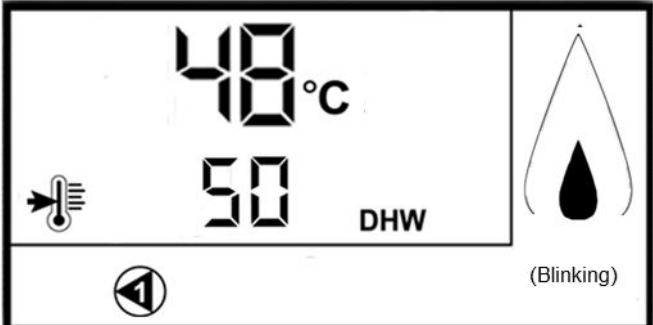

14.2.1 USER CONTROL INTERFACE PANEL

14.3 SEQUENCE OF OPERATION

Operation	Display
<p>1. Upon call for heat the control turns on the integrated pump.</p>	 <p>The display shows a temperature of 48°C, a setpoint of 50, and the label 'DHW'. A flame icon is visible on the right side of the display. A fan icon is on the left. A circular arrow icon is at the bottom left.</p>
<p>2. The control connects 230 VAC to the fan. The fan does not run at this time.</p> <ul style="list-style-type: none"> • If the unit is equipped with a low water cut-off, it must be closed before the control powers up the fan. • If the unit is equipped with a manual reset high limit, it must be closed before the control powers up the fan. • If there is a fan dilution device or similar connected to the unit, the unit will provide 24 VAC to its enable relay. If the fan dilution has a proving switch, it must be closed before the sequence continues. 	 <p>The display shows a temperature of 48°C, a setpoint of 50, and the label 'DHW'. A flame icon is visible on the right side of the display. A fan icon is on the left. A circular arrow icon is at the bottom left.</p>
<p>3. The control starts a 10 second pre-purge cycle.</p>	 <p>The display shows a temperature of 48°C, a setpoint of 50, and the label 'DHW'. A flame icon is visible on the right side of the display, with a solid black drop at its base. A fan icon is on the left. A circular arrow icon is at the bottom left. The text '(Blinking)' is located below the flame icon.</p>
<p>4. Once the pre-purge cycle is complete, and the blocked drain and auto-reset high limit are closed, the control starts the 5 second trial for ignition by sending spark voltage to the spark electrode and opening the gas valve.</p>	 <p>The display shows a temperature of 48°C, a setpoint of 50, and the label 'DHW'. A flame icon is visible on the right side of the display, with a solid black drop at its base. A fan icon is on the left. A circular arrow icon is at the bottom left. The text '(Blinking)' is located below the flame icon.</p>

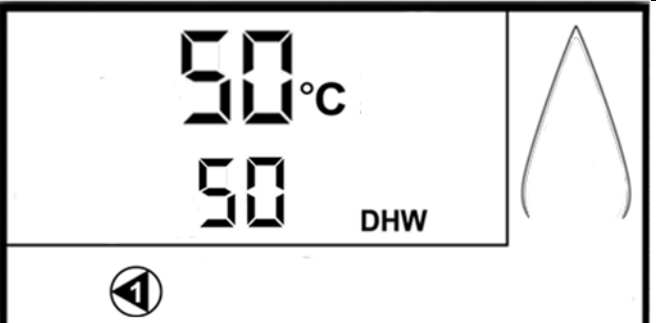
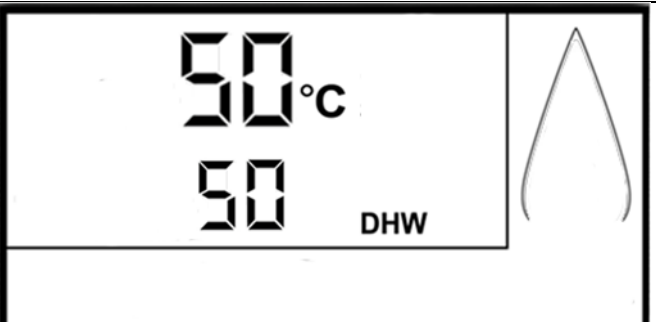
<p>5. If the control does not detect flame by the end of the trial for ignition, the control performs a 10 second post-purge. On the SHW35 CE to SHW116 CE models, the control will perform another pre-purge and try to light the burner again. If the burner does not light after 4 trials, the control will lockout for 1 hour and then try another set of 4 trials. On the SHW146 CE the unit will lockout until manually reset.</p>	
<p>6. If the control detects a flame before trial ignition ends, it begins to modulate the burner in order to maintain the set point.</p>	
<p>7. Once the call for heat is satisfied, the control will turn off the burner. The fan will remain on for the 10-second post-purge cycle. The integrated pump will continue to run for its respective pump delay time., and then turn off</p>	
<p>8. The integrated pump switched off.</p>	

15.0 COMMISSIONING AND TESTING

15.1 ELECTRICAL INSTALLATION

Notes on the requirements for electrical installation are provided in **Section 13.0: ELECTRICAL SUPPLY**. A schematic drawing of the control circuit is shown in **Figure 13.8**

15.2 GAS INSTALLATION

For design see **Section 9.0: GAS SUPPLY**. See **Section 3.0: PRINCIPAL PARTS** for details on the position of the gas connection.

15.3 WATER CONNECTIONS

For design see **Section 12.0: WATER CONNECTIONS**



The system should be thoroughly flushed out with cold water without any circulating pumps in position. Ensure all the valves are open.

If a building return pump is to be fitted, it should be fitted before the system is filled and air locks cleared. Check the system for leaks and repair as necessary. If the system is configured in an unvented arrangement, check the expansion vessel cushion pressure.

15.4 COMMISSIONING THE EQUIPMENT

15.4.1 GENERAL CHECKS PRIOR TO LIGHTING



A person deemed competent must be responsible for the commissioning of this equipment. Before attempting to commission any equipment, ensure that personnel involved are aware of what action is about to be taken and begin by making the following checks:

1. Flue way passages are clear.
2. Adequate ventilation exists in the plant room (if necessary)
3. The system is fully charged with water, ready to receive heat. All necessary valves are open and the building return pump (if fitted) is circulating water.
4. The gas supply pipework is clear of any loose matter, tested for soundness and purged.
5. The condensate drain is installed correctly and the condensate trap is filled with water.



If the condensate trap is not filled before use, products of combustion may escape and can lead to severe personal injury or death

15.4.2 EQUIPMENT CHECKS PRIOR TO LIGHTING

This unit has been designed for a nominal gas inlet pressure of 20 mbar when used on natural gas. Information relating to propane firing can be found in **Section 16.0: LPG FUEL**

1. Gas supply is connected but turned to the “off” position. Any unions or fittings are correctly tightened, test points are closed and the flame sense electrode lead is connected correctly. Ensure the ceramic sheath around the flame sense electrode is not cracked or broken.
2. Ensure electricity supply is connected.
3. Check that the internal circulating pump is fully bled.

15.4.3 PROCEDURE FOR INITIAL LIGHTING

IF THE UNIT IS TO OPERATE ON LPG REFER TO SECTION 16.0 BEFORE PROCEEDING

1. Ensure that the gas-inlet appliance isolating valve, provided by the installer, is in the “off” position.
2. Press the UP button on the user control interface panel for 5 seconds to turn the unit on.
3. The combustion fan should ramp up to full speed to purge the combustion chamber and then drop back to half rate in order to light. The spark generator should create a spark, visible through the burner sight glass. As the gas-inlet appliance isolating valve is closed, the controls should go to a flame failure condition after four ignition attempts (SHW35-245CE– SHW116-410CE) or one ignition attempt (SHW146-410CE). If the above occurs correctly, open the gas-inlet appliance isolating valve and reset the unit by depressing the Enter/Reset button on the control panel.
4. The combustion fan will repeat the pre-purge procedure and attempt to light. Once a flame is established, the LCD display will change to display the Temperature and Set point.
5. Allow the system to reach temperature to check operation of the control sensors.
6. Once the unit has reached temperature and shut down, check that the flame has extinguished.

15.4.4 GAS PRESSURE ADJUSTMENT AND COMBUSTION CHECKS



The Lochinvar EcoShield™ series are supplied with a pre-set gas/air ratio inlet assembly. This must not be tampered with. Any attempt to adjust the gas valve or venturi will invalidate the warranty.

Combustion figures should be as follows:

Model No.	CO ₂	CO
SHW35-245CE	9.0% ±0.5%	<100 ppm
SHW46-325CE	9.0% ±0.5%	<100 ppm
SHW61-325CE	9.0% ±0.5%	<100 ppm
SHW86-410CE	8.8% ±0.5%	<100 ppm
SHW116-410CE	8.8% ±0.5%	<100 ppm
SHW146-410CE	8.8% ±0.5%	<100 ppm

15.4.5 NATURAL GAS COMBUSTION FIGURES

If the combustion figures are not within the range specified, contact Lochinvar Technical support for further guidance.

Combustion figures for Propane firing can be found in **Section 16.0 LPG FUEL**.

15.5 TEMPERATURE ADJUSTMENT PROCEDURE

With the heater firing, the set point can be adjusted by accessing the User Parameter screen on the user control interface panel. To access the User Parameter screen press and hold the **Enter** button for 5 seconds. Next press the **Enter** once to display code **u02**. Use the **Up** and **Down** buttons to display the desired set point. Once the desired set point is displayed, the **Enter** button should be pressed 6 more times to store the value and return the home screen. The set point should be adjusted to ensure that the water is stored at 60°C and distributed at 50°C within 1 (one) minute at all outlets. Care is needed to avoid much higher temperatures because of the risk of scalding. At 50°C the risk of scalding is small for most people, but the risk increases rapidly with higher temperatures and for longer exposure times. The risk to young children and to those with a sensory or mobility loss will be greater. Where a significant scalding risk has been identified, the use of thermostatic mixing valves on baths and showers should be considered to reduce temperature, these need to be placed as close to the point of use as possible.

15.6 INSTALLATION NOISE

If care has been taken to follow the manufacturer’s instructions there should be no discernible noise from the equipment. The allied pump motor may have a level of sound that could lead to consideration for acoustic insulation, but care must be taken not to impede ventilation or airflow to the pump motor.

16.0 LPG FUEL



Note! It is strongly recommended that, on LPG installations, gas detection equipment is fitted. This equipment should be positioned near the appliance and at low level. It is also important that the space housing the appliance is adequately ventilated at high and low level. This appliance must not be located below ground e.g. in a cellar.



Conversion from Natural gas to LPG or vice versa must only be carried out by a suitable qualified person following the procedures outlined within this chapter. Any seals which are broken as part of the adjustments required must be sealed again after completing all works.

16.1 RELATED DOCUMENTS

In addition to those documents listed in **Section 6.1: RELATED DOCUMENTS** within the main body of the installer's guide the gas installation should also comply with the guidance offered in the following documents.

BS 5482-1: 2005

Code of practice for domestic butane and propane gas burning installations.

Part 1: Installations at permanent dwellings, residential park homes and commercial premises, with installation pipework sizes not exceeding dn25 for steel and dn28 for corrugated stainless steel or copper.

The operation of the EcoShield™ range on LPG-Propane (3rd Family) 3P is similar to that on Natural Gas (2nd Family) 2H and the design and installation details described in the main body of the installer's guide should be followed.

16.2 CONVERSION TO LPG



This process must be carried out in the order stated before the water heater is switched on. Failure to follow the following procedure may lead to non-warrantable damage to the water heater. The conversion **MUST** be carried out by a competent person certified for work on LPG fuel.



In the event of any seal or gasket being broken it is essential that the seal or gasket be replaced. Contact Lochinvar limited for replacement seals and gaskets.

Due to the gas/air ratio design of the water heater, the conversion to LPG involves inserting an orifice plate into the gas valve to reduce the gas flow.

Model	Part No.	Stamp	Size
SHW35-245CE	ORF20017	125	4.57 ± 0.025
SHW46-325CE	ORF2022	150	4.98 ± 0.025
SHW61-325CE	ORF2023	210	5.56 ± 0.025
SHW86-410CE	ORF2024	285	6.76 ± 0.025
SHW116-410CE	ORF2025	7.2	7.20 ± 0.02
SHW146-410CE	ORF20003	6.0	6.00 ± 0.02

16.2.1 LPG ORIFICE MARKINGS

If the water heater is already installed and operational, you must turn off the gas supply, turn off the power supply and allow the water heater to cool before proceeding. The conversion procedure is as follows:

16.2.2 SHW35-245CE – SHW86-410CE

1. Remove the front access cover from the unit.
2. Remove the impulse tube and wiring plug from the gas valve.
3. Remove the four screws securing the gas valve to the venturi (**Figure 16.2.3**).
4. Locate the propane orifice disk from the conversion kit bag. Verify that the stamping on the orifice disk is correct for the water heater (see **Table 16.2.1**). Place the orifice into the black rubber grommet in the front of the gas valve ensuring the orifice and grommet are seated correctly (**Figure 16.2.3**).
5. Reposition the gas valve against the venturi and replace the screws (**Figure 16.2.3**) securing the valve to the venturi.
6. Refit the impulse tube and wiring plug to the gas valve.
7. After installation is complete, attach the propane conversion label (in the conversion kit bag) next to the water heater rating plate. Attach the LP caution label (in the conversion kit bag) to the left side of the unit in the lower left corner.
8. Replace the front access cover.

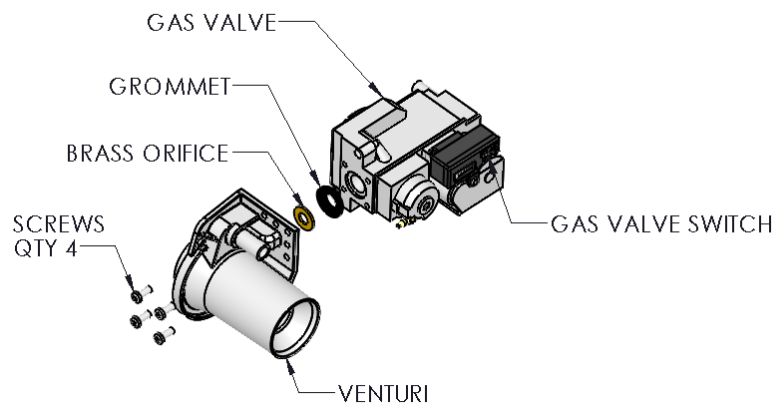

16.2.3 CONVERSION PROCEDURE SHW35-2455CE – SHW86-410CE

16.2.4 SHW116-410CE

1. Remove the front access cover from the unit.
 2. Remove the impulse tube and wiring plug from the gas valve.
 3. Remove the three screws securing the venturi to the fan.
- NOTE:** When separating the venturi from the fan, take care not to damage the O-ring inside the fan (**Figure 16.2.5**).
4. Remove the four cap-head screws securing the gas valve to the venturi (**Figure 16.2.5**).
 5. Locate the propane orifice disk from the conversion kit bag. Verify that the stamping on the orifice disk is correct for the water heater (see **Table 16.2.1 LPG ORIFICE MARKING**).
 6. Remove the existing orifice from the O-ring in the side of the gas valve and replace it with the orifice from the kit. Position and secure the orifice in the valve as shown in **Figure 16.2.5**.
 7. Reposition the gas valve against the venturi and replace the star-drive screws (**Figure 16.2.5**) securing the valve to the venturi.
 8. Inspect the O-ring inside the fan. Handle the O-ring with care, do not damage. Reposition the venturi against the fan and replace the screws securing the venturi to the fan (**Figure 16.2.5**).
 9. Refit the impulse tube and wiring plug to the gas valve.
 10. After installation is complete, attach the propane conversion label (in the conversion kit bag) next to the water heater rating plate. Attach the LP caution label (in the conversion kit bag) to the left side of the unit in the lower left corner.
 11. Replace the front access cover.

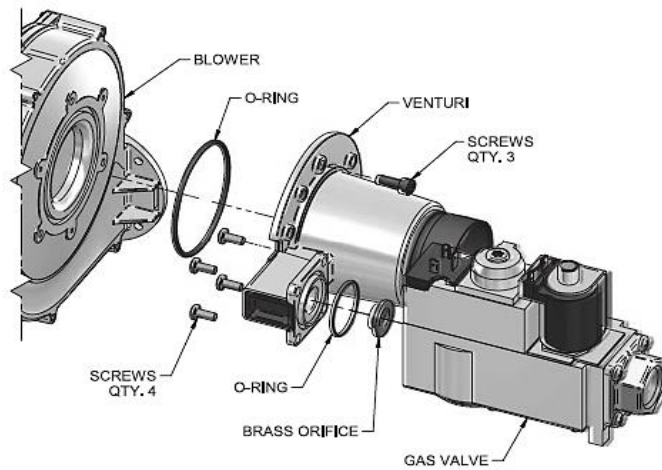

16.2.5 CONVERSION PROCEDURE SHW116-410CE

16.2.6 SHW146-410CE

1. Remove the front access covers from the unit.
2. Remove the gas valve and manifold from the unit via the unions on each end (**Figure 16.2.7**).
3. Remove the three screws mounting the injector plate on the air shroud (**Figure 16.2.7**).
4. Remove the four screws securing the manifold adapter to the injector plate taking care not to damage the O-ring.
5. Locate the propane orifice from the conversion kit bag. Verify that the stamping on the orifice disk is correct for the water heater (see **Table 16.2.1LPG Orifice Markings**).
6. Remove the existing orifice from the O-ring in the side of the injector plate and replace it with the orifice from the kit. Position and secure the orifice in the injector plate as shown in **Figure 16.2.7**.
7. Reposition the manifold adapter to the injector plate and replace the four manifold adapter mounting screws. Handle the O-ring with care, do not damage.
8. Reposition the injector plate to the air shroud and replace the three injector plate mounting screws.
9. After installation is complete, attach the propane conversion label (in the conversion kit bag) next to the water heater rating plate. Attach the LP caution label (in the conversion kit bag) to the left side of the unit in the lower left corner.
10. Replace the front access covers.

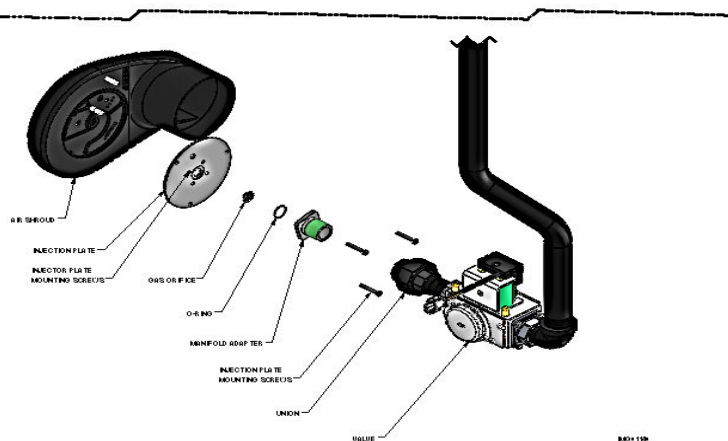

16.2.7 CONVERSION PROCEDURE SHW146-410CE

16.3 LPG COMMISSIONING AND TESTING

The commissioning procedure on LPG is similar to that when the heater is firing on Natural Gas. As such, the same procedure should be followed taking in to account the following information:

16.3.1 LPG PRESSURE ADJUSTMENT AND COMBUSTION CHECKS



EcoShield™ are supplied with a pre-set gas/air ratio inlet assembly. This must not be tampered with. Any attempt to adjust the gas valve or venturi will invalidate the warranty.

Combustion figures should be as follows:

Model No.	CO ₂	CO
SHW35-245CE	10.5% ±0.5%	<100 ppm
SHW46-325CE	10.5% ±0.5%	<100 ppm
SHW61-325CE	10.5% ±0.5%	<100 ppm
SHW86-410CE	10.5% ±0.5%	<100 ppm
SHW116-410CE	10.5% ±0.5%	<100 ppm
SHW146-410CE	10.5% ±0.5%	<100 ppm

16.3.2 LPG COMBUSTION FIGURES

If the combustion figures are not within the range specified, contact Lochinvar Technical support for further guidance.

17.0 MAINTENANCE

17.1 GENERAL



Keep appliance area clear and free from combustible materials and flammable vapours and liquids.

A competent person should check and ensure that the flue, its support and terminal, the ventilation to the boiler house, safety valve, drain, pressure gauge etc. are in a serviceable and working condition and still comply with the relevant standards and codes of practice, as detailed in **Section 6.0: GENERAL REQUIREMENTS**.

Servicing is recommended at intervals no greater than 12 months to ensure trouble free operation. Even if the maintenance schedule for the storage vessel is determined to be less than annually, it is important that all controls and safety features are checked for correct operation on an annual basis.

Measuring flue gas CO₂ and flue gas temperatures will give an indication of the state of the flue and burner. Results of the flue gas analysis should be compared with previously measured values to identify a possible loss of efficiency.

17.2 BURNER INSPECTION

The heat exchanger has a sight glass for inspection of the flame picture.



If the appliance has been in recent operation, this area may be hot. Appropriate precautions should be taken to prevent personal injury.

To check the flame picture at high and low fire, the following procedure should be followed:

1. Place the water heater into service mode. To access the service mode press and hold the **Enter** and **Up** buttons simultaneously for 5 seconds.
2. The heater should ramp up to full firing rate
3. Check the flame condition.
4. Press the **Enter** button momentarily, this should ramp the water heater down to low rate.
5. Check the flame condition.
6. Press and hold the **Enter** button for 5 seconds to take the unit out of service mode.

17.3 BURNER REMOVAL

If it has been determined that the flame picture is unacceptable, the burner can be removed and cleaned using the following procedure:

1. Isolate the electrical and gas supplies to the heater.
2. Allow the boiler to cool down.
3. Disconnect the wiring connections to the ignition electrode.
4. Disconnect the power and control connection leads and earthing wire from the combustion fan.
5. Apply suitable release oil to the 6 studs around the edge of burner door.
6. Remove the 6 retaining nuts around the edge of the burner door.



Once loosened, the nuts should be removed by hand. If any of the nuts seize, the nut should gently be re-tightened and additional release oil used.

7. Withdraw the heat exchanger front plate and burner assembly from the heat exchanger complete with the combustion fan.
8. With the burner assembly away from the boiler, the burner can be gently cleaned with the brush attachment of a vacuum cleaner.

The reassembly procedure is the reverse of the above taking care to ensure that the for the heat exchanger front plate sealing gasket, the combustion fan connection gasket, the burner door insulation and the combustion chamber rear wall insulation are in good condition or are replaced as necessary.



Note: particular attention should be paid to the combustion chamber rear wall insulation. If any deterioration in the insulating material is noted, the insulation panel must be replaced.

17.4 CLEANING THE HEAT EXCHANGER

To clean the heat exchanger, the following procedure should be carried out:

1. Remove the burners as above.
2. Use a vacuum cleaner to remove any accumulation on the heating surfaces.
3. Inspect the heat exchanger to ensure that the 1 mm flue way is clear between all coils.
4. If any debris is still present, brush the heat exchanger with a non-metallic brush taking care not to damage the insulation panel on the rear wall of the heat exchanger.



A kit of components to aid with cleaning the heat exchanger is available from Lochinvar Limited. For models SHW35-245 use part number KIT30062 for SHW46-325CE– SHW116-410CE use part number KIT30063, for model SHW146-410CE use part number KIT30064.



It is very important to inspect and remove all deposits from the heat exchanger. If all deposits cannot be removed from the heat exchanger, contact Lochinvar Technical support for further guidance.

5. Once the heat exchanger has been brushed it should be rinsed with fresh water to remove all residues.
6. Remove the condensate water trap and clean out any debris.
7. Refit the condensate drain and fully recharge by pouring 1 litre of water through the heat exchanger coils.
8. Reinstall the burner.
9. Restart the heater as detailed in **Section 15.4.3: PROCEDURE FOR INITIAL LIGHTING.**

17.5 DRAINING THE WATER HEATER SYSTEM

Maintenance and service procedures for the storage vessel require draining the water heater. The water heater must also be drained if it is to be shut down and exposed to freezing temperatures.

1. Turn off the water heater by pressing and holding the **Up** button for 5 seconds.
2. Connect a hose to the system drain valve.
3. Locate hose's discharge in an area where hot water will not cause any damage or injury.
4. Close the cold-water inlet valve to water heater system.
5. Open a nearby hot water outlet to vent the system.
6. Open the drain valve.
7. If the water heater is being drained for an extended shutdown, it is suggested the drain valve be left open during this period.



Note: The heat exchanger cannot be completely drained of water without purging with compressed air at a pressure of 1 bar.

17.6 STORAGE VESSEL: INSPECTION AND CLEANING

1. Drain the heater. Refer to **Section 17.5: DRAINING THE WATER HEATER SYSTEM.**
2. Remove outer cover plate from lower side of water heater jacket.
3. Remove cover and gasket from cleanout opening.
4. Remove scale or sediment using care not to damage the vitreous enamel lining.
5. Inspect cleanout plate gasket and replace if necessary.
6. Install gasket and cleanout plate. Draw plate up square by tightening screws evenly.

17.7 SACRIFICIAL ANODES: INSPECTION AND REPLACEMENT

If the Correx non-sacrificial anode protection system is used, there is no requirement to check the condition of the anodes.

The tank is protected against corrosion by means of two sacrificial anodes fitted in the front of the storage vessel. The rate at which the anodes are eroded is dependent on the quality of the water; therefore it is essential that the anodes are inspected **at least once a year**.

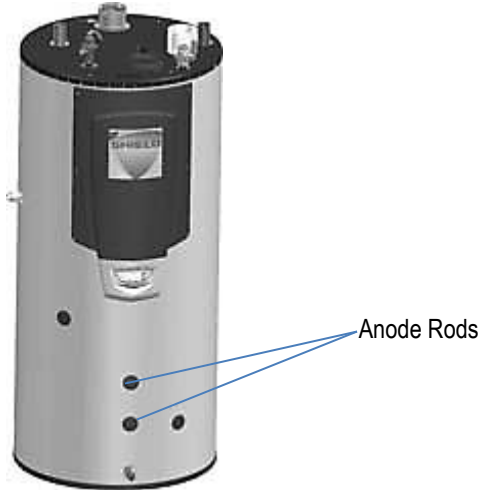

1. Drain the water heater. Refer to **Section 17.5: DRAINING THE WATER HEATER SYSTEM**.
2. Remove the outer caps covering the anodes.
3. Remove each anode and inspect its condition. If the anode has reduced in size by more than 40% or if the surface is severely pitted, the anode should be replaced. Particular attention should be paid to the ends of each anode to ensure excessive localised depletion has not occurred.
4. When refitting the inspected or replaced anode, a suitable jointing compound should be applied to the threads of the anode to prevent water leakage.

17.8 REFILLING THE SYSTEM

1. Close the drain valve.
2. Open a hot water fixture to allow air to escape.
3. Open the cold water supply to water heater and allow the tank to fill.
4. Follow the lighting instructions as detailed in **Section 15.4.3: PROCEDURE FOR INITIAL LIGHTING**.
5. Check for water leakage.

17.9 OTHER CHECKS

17.9.1 AIR PRESSURE SWITCH LINES

During the annual service, check the lines to/from the air pressure switch to ensure:

1. They are correctly fitted
2. There is no damage

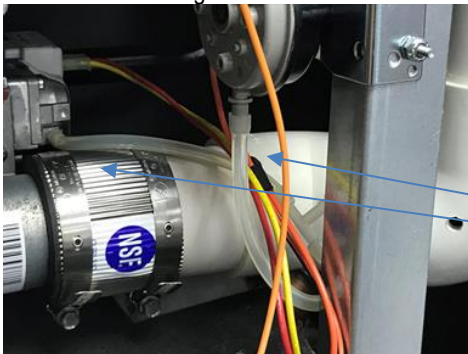

Check all connections

17.9.2 RELIEF VALVE

At least once a year, the temperature and pressure relief valve and safety valve should be checked to ensure that they operate correctly. To check the valves, the manual override levers should be operated several times. The valves should seat properly and operate freely.

If water does not flow, drain the heater, remove the inoperative valve and inspect for obstructions or corrosion. Replace with a new valve of the recommended size as necessary.

17.9.3 FLUE SYSTEM

Examine the exhaust and air intake system every 12 months. Points of inspection are as follows:

1. Check for obstructions and/or deterioration of flue pipe and terminal. Replace immediately where needed.
2. Check the terminal for any foreign material and remove as necessary
3. Check all flue system connections for leakage and reseal as required.
4. Check that ventilation grilles comply with current regulations.

17.9.4 AIR INTAKE CONNECTION

During the annual maintenance inspection the coupling piece between the fan housing and air inlet tube should be checked to ensure it is correctly fitted and secure.

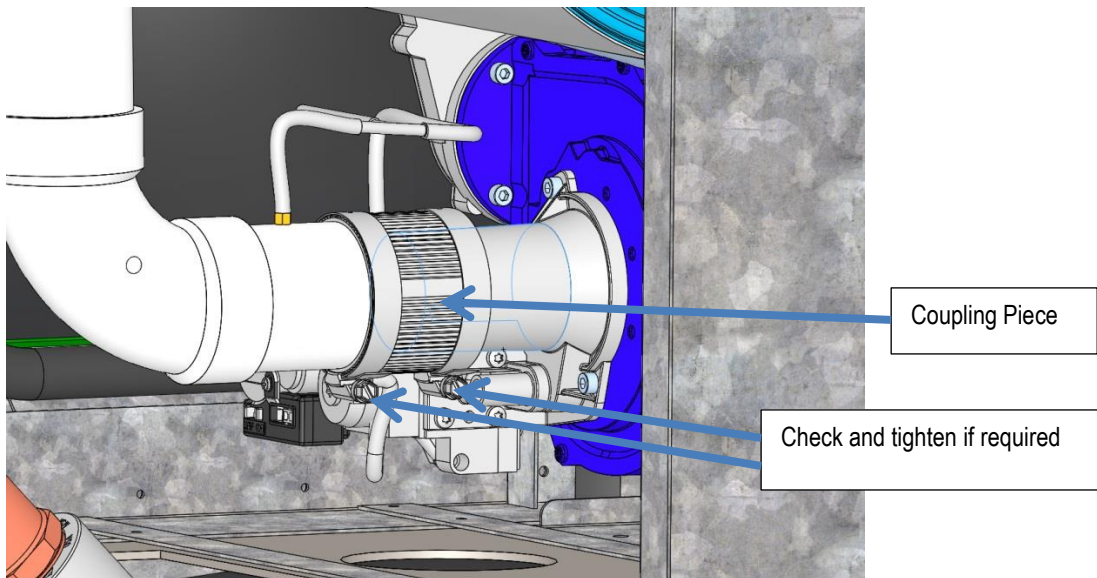

Fig 15.9 Air intake connection

17.9.5 CONDENSATE NEUTRALISATION KIT

If fitted, the condensate neutralisation kit will require replacing after 12 months of operation. Please refer to the item specific instructions for further details.

17.9.6 REPLACING THE HEAT EXCHANGER

If correct water softening precautions are not taken the heat exchanger could become blocked or even split due to scale build up within the heat exchanger, if this happens the heat exchanger will need to be replaced. Replacement assemblies are available and include all spares required to replace the heat exchanger. Lochinvar can provide a quote to carry out the replacement work if required.

Replacement heat exchanger assembly item numbers are shown below contact Lochinvar customer service for prices and availability

Heat exchanger replacement assemblies	
Model	Item number
SHW35-245	LL200030P
SHW46-325	LL200031P
SHW61-325	LL200032P
SHW86-410	LL200033P
SHW116-410	LL200034P
SHW146-410	LL200035P

18.0 USER CONTROL INTERFACE SETTINGS

18.1 TIME AND DATE

The control uses an internal clock for the night setback feature and for logging of events. For these features to work correctly, the clock must be set when the water heater is first installed or anytime the water heater has been powered off for more than 15 minutes.

Note that hours are displayed as 24 hour time (2:00PM = 14:00).

Days are displayed as a number (Monday = 1, Tuesday = 2, Sunday = 7).



The internal clock does not adjust for British summer time and therefore, will require a manual adjustment.

18.2 USER ADJUSTABLE PARAMETERS SCREEN

To access the User Adjustable Parameters screen press and hold the **ENTER** button for 5 seconds. Once pressed the user code u01 should be shown in the lower digits. There are seven parameters that can be set. Use the **UP** and **DOWN** buttons to scroll and the **ENTER** button to make selection. Once you have cycled through all of the parameters, the new values will be set.

16.1.1 CODE u01

Temperature units (°C/°F) – Press **UP** or **DOWN** to display the desired temperature unit and then press **ENTER** to make selection.

16.1.2 CODE u02

Hot Water Set Point – The factory default setting is 52°C. The target temperature can be set between 16°C and 85°C. Press **UP** or **DOWN** to display the desired temperature and then press **ENTER** to make selection.

16.1.3 CODE u03

Year – Press **UP** or **DOWN** to display the current year and then press **ENTER** to make selection.

16.1.4 CODE u04

Month – Press **UP** or **DOWN** to display the current month and then press **ENTER** to make selection.

16.1.5 CODE u05

Day – Press **UP** or **DOWN** to display the current day and then press **ENTER** to make selection.

16.1.6 CODE u06

Hour – Hours are displayed as 24 hour format. **UP** or **DOWN** to display the current hour and then press **ENTER** to make selection.

16.1.7 CODE u07

Minute – Press **UP** or **DOWN** to display the current minute and then press **ENTER** to make selection.

18.3 INSTALLER ADJUSTABLE PARAMETERS SCREEN

To access the Installer Adjustable Parameters screen press and hold the **ENTER** and **DOWN** buttons simultaneously for 5 seconds. Once pressed the installer code P01 should be shown in the lower digits. Once you have cycled through all of the parameters, the new values will be set.

16.2.1 CODE P01

Manual Reset High Limit Set Point – The factory default setting is 98°C. The manual reset high limit set point can be set between 0°C and 98°C. Press **UP** or **DOWN** to display the desired temperature and then press **ENTER** to make selection. When changes to Manual Reset High Limit Set Point are saved the burner will shut off and automatically re-ignite.

16.2.2 CODE P02

Night Setback Offset – The factory default setting is 0. The night setback offset can be set between 0 and 50. Press **UP** or **DOWN** to display the desired offset and then press **ENTER** to make selection. When changes to Night Setback Offset are saved the burner will shut off and automatically re-ignite.

16.2.3 CODE P03

Maximum Tank Set Point – The factory default setting is 52°C. The maximum tank set point can be set between 0°C and 87°C. Press **UP** or **DOWN** to display the desired temperature and then press **ENTER** to make selection. When changes to Maximum Tank Set Point are saved the burner will shut off and automatically re-ignite.

16.2.4 CODE P04

HW Pump Delay – The default time is 30 seconds. The HW pump delay can be set between 0 seconds and 40 minutes. Press **UP** or **DOWN** to display the desired time and then press **ENTER** to make selection. When changes to HW Pump Delay are saved the burner will shut off and automatically re-ignite.

18.4 PASTEURISATION FUNCTION (USING NIGHT SET BACK FACILITY)

18.4.1 THE PROCEDURE FOR A WEEKLY HIGH TEMPERATURE (70°C) PASTEURISATION IS AS FOLLOWS:

- Access the installer menu (**Down & Enter** for 5 seconds).
- Set parameter **p02** to 15°C (this is a deduction from the pasteurisation temperature and can be reduced to 10°C if a 65°C storage temperature is required instead of 60°C).
- Set parameter **p03** to 75°C (this is the maximum setpoint).
- Exit the installer menu.
- Access the user menu (**Enter** for 5 seconds)
- Set parameter **u02** to 75°C (this is the pasteurisation temperature)
- Check that parameters **u03** to **u07** give the correct date and time.
- Exit the user menu.
- Access the setback function menu (**Up & Down** for 5 seconds).
- Set the trigger values as follows:

Trigger	Day	Time
On 1	1	00:00
Off 1	1	23:59
On 2	2	00:00
Off 2	2	23:59
On 3	3	00:00
Off 3	3	23:59
On 4	4	00:00
Off 4	4	23:59
On 5	5	00:00
Off 5	5	23:59
On 6	6	00:00
Off 6	6	23:59
On 7	7	02:00
Off 7	7	23:59

- Exit the setback function menu (**Enter** for 5 seconds)

This will cause the water heater to operate at the reduced temperature between 00:00 and 23:59 each day with the exception of Sunday morning when the reduced temperature will not become active until 02:00 i.e. from 23:59 on Saturday night until 02:00 on Sunday the set point will be 75°C

18.4.2 THE PROCEDURE FOR A DAILY PASTEURISATION WHEN SUPPLYING DOMESTIC HOT WATER AT LESS THAN 60°C:



Systems must always comply with the requirements of L8, running the water heaters at low temperatures may encourage the growth of legionella bacteria.

- Access the installer menu (**Down & Enter** for 5 seconds).
- Set parameter **p02** to temperature required less than standard pasteurisation setting of 65°C (if the daily set point is to be 50°C for example then this would be set at 15°C).
- Set parameter **p03** to 65°C (this is the pasteurisation setting).
- Exit the installer menu.
- Access the user menu (**Enter** for 5 seconds)
- Set parameter **u02** to 75°C (this is the pasteurisation temperature)
- Check that parameters **u03** to **u07** give the correct date and time.
- Exit the user menu.
- Access the setback function menu (**Up & Down** for 5 seconds).
- Set the trigger values as follows:

Trigger	Day	Time
On 1	1	23:59
Off 1	1	00:59
On 2	2	23:59
Off 2	2	00:59
On 3	3	23:59
Off 3	3	00:59
On 4	4	23:59
Off 4	4	00:59
On 5	5	23:59
Off 5	5	00:59
On 6	6	23:59
Off 6	6	00:59
On 7	7	23:59
Off 7	7	00:59

- Exit the setback function menu (**Enter** for 5 seconds)

This will cause the water heater to operate at the reduced temperature between 00:59 and 23:59 each day with the exception of the period from 23:59 until 00:59 when the set point will be 65°C



During the pasteurisation period, any outlets without temperature limiting devices fitted will have very hot water, suitable precautions should be taken to inform all potential users.

18.5 NIGHT SETBACK SCREEN

To access the Night Setback screen press and hold the **UP** and **DOWN** buttons simultaneously for 5 seconds. Once pressed the trigger type, On/OFF, should be shown in the upper digits of the display.

- 1) Use the **UP** and **DOWN** buttons to display the desired trigger type, On or OFF and then press **ENTER** to make selection.
- 2) The trigger number will then appear, On1 or OFF1 depending on previous selection, in the upper digits on the display. On1 is the first trigger to lower the tank set point to the selected Night Setback Offset, see section 16.2.2. Press **ENTER**.
- 3) Next the day of the week will appear in the lower digits of the display, (1 = Monday, 2 = Tuesday, ect.). Press **UP** or **DOWN** to display the desired day of the week and then press **ENTER** to make selection.
- 4) The time for that trigger will then appear in a 24 hour format with the hour digits flashing in the lower digits of the display. Press **UP** or **DOWN** to display the desired hour and then press **ENTER** to make selection.
- 5) The minute's digits will then start flashing. Press **UP** or **DOWN** to display the desired minutes. If all triggers have been set, press and hold the **ENTER** button for 5 seconds. When Night Setback triggers are saved the burner will shut off and automatically re-ignite. Otherwise press the **ENTER** button once. The lower digits will clear and the upper digits will display the trigger type again, On or OFF. Go back to step 2 of this procedure to set all desired triggers.

18.6 SERVICE MODE SCREEN

To access the service mode screen press and hold the **ENTER** and **UP** buttons simultaneously for 5 seconds. Once pressed the heater will ramp up to full rate and the display will show a spanner icon on the lower right. The outlet temperature will display in the upper digits and the fan speed, in rpm, will show in the lower digits. The unit can be ramp down to minimum rate by pressing the **ENTER** button and then back to full rate by pressing **ENTER** again. The **UP** and **DOWN** buttons can be used to scroll through the entire fan speed range. To exit service mode press and hold the **ENTER** button for 5 seconds or press no buttons for 10 minutes.

18.7 ERROR LOG SCREEN

The water heater automatically stores the 10 most recent errors. To access the error log screen press and hold the **DOWN** button for 5 seconds. Once pressed the upper digits should display "1", being the most recent. The lower digits will display the following information in 2 second intervals.

- 1) Error Code
- 2) Hour and Minute of the error
- 3) Date of the error
- 4) Year of the error

To view the next errors press the **UP** button. To pause the information in the lower digits press and hold the **ENTER** button, when released the next piece of information will display again in 2 second intervals. To exit the error log screen press and hold the **DOWN** button for 5 seconds.

19.0 TROUBLESHOOTING

19.1 CHECKING TEMPERATURE SENSORS

The water heater temperature sensors are all resistance type devices. The following tables show the correct value for the sensors at various temperatures. Use an ohmmeter to read the resistance of the sensor at a known temperature, if the resistance does not closely match the value shown in the table replace the sensor.

Temp °C	Resistance Ω	Temp °C	Resistance Ω
10	18.780	70	1.990
20	12.263	80	1.450
30	8.194	90	1.084
40	5.592	100	817
50	3.893		
60	2.760		

19.1.1 INLET/OUTLET TANK SENSOR RESISTANCE

Temp °C	Resistance Ω	Temp °C	Resistance Ω
20	14.773	80	1.707
30	9.804	90	1.266
40	6.652	100	952
50	4.607	110	726
60	3.252	120	560
70	2.337		

19.1.2 FLUE TEMPERATURE SENSOR RESISTANCE

19.2 TROUBLESHOOTING CHART

FAULT	CAUSE	CORRECTIVE ACTION
No Display	No power to unit	Check external line fuse Check wiring harness connection between display board and main board. Connect harness at both points
	Faulty Display Board	Replace board
	Faulty Main control board	Replace main control board
	Blown Fuse	Replace fuse F3 on main control board, see 13.6 for details
Burner not firing	Tank set point satisfied	Review temperature setting
	Unit Locked out	Consult display for specific fault see 19.3for details
Unit does not modulate above 50%	Flue Sensor open	Check flue sensor is located in flue outlet
		Check wiring connection at flue sensor
		Check resistance of flue sensor with table 19.1
Noisy Operation	Gas supply pressure problem	Refer to Section 3 Technical data
	Gas/air mixture problem	Contact Lochinvar Ltd
	Dirty/damaged burner	Remove and inspect/clean burner
	Low water flow	Check operation of Primary pump
	Air in system	Check heat exchanger has been fully vented of air
Primary pump non operational	Blown Fuse	Replace F5 fuse on main control board, see 13.6for details
	Faulty pump	Replace pump
	Faulty pump relay	Replace pump relay
	Internal fault on control board	Replace main control board

19.2.1 TROUBLESHOOTING CHART

19.3 ERROR CODES

The user interface screen gives information on Error codes; these can be one of three types:

1. Lockout codes, this may require a user reset and/or investigation by a service engineer
2. Blocking codes, this may require investigation by a service engineer
3. Notification codes, the unit will continue to operate but a service engineer will be required

Error Codes	Description	Corrective Action
E00	Invalid lockout	Reset control module Switch power on /off Replace control module
E01	Memory lockout	Replace control module
E02	Fan speed fault	Check flue and air intake length is not too long Check for obstruction or blockages within flue system Check wiring connections on fan and main control board Replace the fan Replace the main control board
	Blown fuse	Replace Fuse F2 on main control board see 13.6
E04	Flow switch fault	Check pump operates on call for heat Check for closed valves or obstructions Check system full
	Blown fuse	Replace fuse F3 on main control board see 13.6
E05	Flame out of sequence	Verify flame not present, if present replace gas valve Check 230v supply polarity is correct Check external wiring for voltage feedback Check flame rod is clean Check internal wiring for poor connections Replace main control board
E06	Auto reset Hi limit	Check sensor setting is correct Check appliance has been filled correctly Check primary pump operation Check sensor resistance correct see table 19.1
E07	Thermal Fuse open	Check wiring connections to the fuse on the heat exchanger Check continuity if open contact Lochinvar Ltd
E08	Ancillary proving switch	Check ancillary operating correctly Check wiring to switch
E09	Blocked condense drain	Check for blockages in condense trap/pipework Check wiring and switch
E10	Air pressure switch/HEX Limit-contacts are open	Check wiring connections to switch Check for blockage in air inlet Check hoses to switch for blockages Inspect burner and clean/replace as necessary Inspect heat exchanger clean as necessary Faulty air pressure switch, replace

Continued over page

Error Codes	Description	Corrective Action
E11	Flame signal lost 4 times	Inspect spark electrode and associated wiring for damage and correct connection, replace if required Check for correct electrical earthing Check incoming gas supply pressure is correct refer to section 9.0 gas supply Verify the plastic hose from the gas valve to the air inlet is connected and undamaged Verify the air intake/flue exhaust pipes are correctly installed and that there are no obstructions
E12	Failed main burner ignition attempt 4 times	Check for 24v to the gas valve at the 2 pin connector on the side of the main control board during ignition. If no voltage present replace the control board If 24v present at the main control board, check the wiring between the board and the gas valve. Replace if required. Do not disconnect the wiring from the gas valve and attempt to measure a voltage at that point, the board will detect the gas valve is not connected and display a gas valve fault.
n05	The fan speed is being increased due to the flame current going below 5microamps	If 24v is present check the gas valve is opening using a manometer connected to the outlet of the gas valve. During pre-purge there should be a negative pressure when the valve is energized there should be a positive pressure. If these do not occur replace the faulty gas valve. Inspect flame sensor and associated wiring, replace if required. Inspect and clean the heat exchanger. Inspect the burner and clean, replace if required. Replace the main control board.
E13	The flue temperature has exceeded 121°C	Inspect and clean the heat exchanger
b05	The flue temperature has exceeded 115°C	Inspect the flue sensor, measure the resistance of the sensor and compare with table 19.1.,replace if required
n04	The fan speed is being limited due to the flue temperature exceeding 100°C	Verify the air intake/flue exhaust pipes are correctly installed and that there are no obstructions Replace the main control board.
E15	The outlet temperature has exceeded the 98°C manual reset high limit setting	Verify the system is full of water and all air has been purged from the system, pay particular attention to the EcoShield™ heat exchanger
b03	The outlet water temperature has exceeded 90°C	Verify the water heater has been piped correctly Check the shunt pump is operating, if not check wiring back to the main control board
n02	The fan speed is being limited due to the outlet water temperature exceeding 85°C	Replace the main control board if required If the wiring is Ok and there is 230v to the pump replace the pump Check resistance of water sensors with table 19.1, replace sensor if required.
E18	The control module reads an excessive DT between the 2 sensors	Check wiring to sensor, make sure all is correctly connected and undamaged Check resistance of water sensors with table19.1 , replace sensor if required. Replace control module
E19	One or both flue sensors is open or shorted	Inspect the flue sensors, measure the resistance of the sensors and compare with table19.1.,replace if required Replace control module

Continued over page

Error Codes	Description	Corrective Action
E21	One or both outlet sensors is open or shorted	Check wiring to sensor, make sure all is correctly connected and undamaged Check resistance of sensors with table 19.1, replace sensor if required.
E22	Inlet sensor is open	Check wiring to sensor, make sure all is correctly connected and undamaged
E23	Inlet sensor is shorted	
b01	The temperature has reached the set point +4°C	None
b02	The control has received a call for heat too soon after the previous call for heat ended	The control will allow the burner to fire after 60 seconds or if the outlet temperature drops 10°C
b04	The temperature rise across the heat exchanger has exceeded 30°C	Verify the system is full of water and all air has been purged from the system, pay particular attention to the EcoShield™ heat exchanger Check the shunt pump is operating, if not check wiring back to the main control board
n03	The fan speed is being limited due to the temperature rise across the heat exchanger exceeding 25°C	Replace the main control board if required If the wiring is Ok and there is 230v to the pump replace the pump Check for scale accumulation within the heat exchanger
b06	Low voltage on main control board	Check supply Check wiring connections at the low voltage terminal strip Replace the transformer Check 24v
n01	The flue temperature did not change after the burner started firing	Check the flue sensor is installed and positioned correctly Check the sensor and wiring table 19.1, replace if required
n06	Tank sensor is not connected	Check sensor and wiring, replace if required
n07	Inlet sensor disconnected	Check sensor and wiring, replace if required Check resistance of sensors with table 19.1, replace sensor if required.
n08	Inlet sensor shorted	Check sensor and wiring, replace if required Check resistance of sensors with table 19.1, replace sensor if required.

19.3.1 ERROR CODES

Blocking Codes	
b01	Set point met
b02	Anti-cycling
b03	Outlet temperature too high
b04	Delta T too high
b05	Flue temperature too high
b06	Low voltage

19.3.2 BLOCKING CODES

Notification Codes	
n01	Fan limited due to no flue sensor change
n02	Fan limited due to high outlet temperature
n03	Fan limited due to high Delta T
n04	Fan limited due to high flue temperature
n05	Fan increased due to low flame current
n06	Tank sensor is open
n07	Inlet sensor open
n08	Inlet sensor shorted

19.3.3 NOTIFICATION CODES

20.0 ErP SPECIFICATION DATA SHEET

Water Heater Type:		SHW35-245	SHW46-325	SHW61-325	SHW86-410	SHW116-410	SHW146-410
Manufacturer	Lochinvar Limited						
Load Profile		XXL	XXL	3XL	3XL	3XL	3XL
Energy Efficiency	%	76%	73%	81%	79%	78%	79%
Daily Electricity Consumption	Qelec	0.333	0.382	0.541	0.517	0.531	0.552
Daily Fuel Consumption	Qfuel	31.398	32.893	56.18	58.399	59.236	57.952
Mixed water V40 @40oC	litre	∞	∞	512	1352	∞	∞
Emissions of Nitrogen Oxides According to EU regulation 812/2013	mg/kwh	25.3	33	27.3	33.1	40	38
Sound Power Level (EN 15036-1:2006)	LWA(db)	56	58	60	62	64	66

21.0 USER INSTRUCTIONS

Once the installation and commissioning is complete, the equipment owner or their representative should be made aware of the lighting and operating instructions. A practical demonstration should be given describing each functional step. Incorrect use may result in injury and will also invalidate the warranty. The Installation, Commissioning and Maintenance Instructions should be handed over and kept in a safe place for easy reference. It is strongly recommended that the users read and understand the separate User and Control Guide

NOTES



IMPORTANT INFORMATION

These instructions must be read and understood before installing, commissioning, operating or maintaining the equipment.

