

The EcoForce++™ range

High Efficiency Gas Fired Condensing Water Heaters
Installation, Commissioning and Maintenance
Instructions

Models:

EF+35/150+

EF+35/230+

EF+55/230+



1.0	DISPLAY CODES	3
1.1	DOUBLE NUMBERS.....	3
1.2	DIAGNOSTIC CODES	3
1.3	ERROR CODES	3
2.0	INTRODUCTION.....	4
2.1	PRINCIPAL PARTS	5
3.0	TECHNICAL DATA	6
4.0	GENERAL REQUIREMENTS	8
4.1	RELATED DOCUMENTS	8
5.0	WATER QUALITY	9
6.0	LOCATION	9
6.1	PLANT ROOM REQUIREMENTS.....	9
6.2	GENERAL REQUIREMENTS	9
6.3	CLEARANCES.....	9
6.4	CONDENSATE DRAIN	10
7.0	GAS SUPPLY	10
7.1	SERVICE PIPES.....	10
7.2	METERS	10
7.3	GAS SUPPLY PIPES.....	10
7.4	BOOSTED SUPPLIES	10
7.5	PLANT-ROOM CONTROL VALVE	10
7.6	EQUIPMENT GAS SYSTEM LEAK CHECK.....	10
8.0	FLUE SYSTEM	11
8.1	FLUE SYSTEM GENERAL REQUIREMENTS	11
8.2	APPROVED FLUE SYSTEM.....	11
8.3	INSTALLATION PRECAUTIONS.....	12
8.4	MAXIMUM LENGTH – CONCENTRIC FLUE	12
8.4.1	WORKED EXAMPLE – CONCENTRIC FLUE	12
8.5	MAXIMUM LENGTH – CONVENTIONAL FLUE	12
8.5.1	WORKED EXAMPLE – CONCENTRIC FLUE	13
8.6	FLUE DISCHARGE.....	13
8.7	FLUE TERMINAL INSTALLATION.....	13
8.7.1	TYPE B ₂₃ (CONVENTIONAL FLUE).....	13
8.7.2	TYPE C ₁₃ (HORIZONTAL BALANCED FLUE).....	13
8.7.3	TYPE C ₃₃ (VERTICAL BALANCED FLUE).....	14
8.8	FLUE TERMINAL GUARDING	15
8.9	CONDENSATE DRAIN	15
9.0	AIR SUPPLY	15
9.1	COMBUSTION VENTILATION	15
9.2	COOLING VENTILATION.....	16
10.0	WATER CONNECTIONS	17
10.1	INSTALLATION SCHEMATIC DRAWINGS.....	17
10.2	OPEN VENTED SYSTEM ARRANGEMENT.....	19
10.3	UNVENTED SYSTEM ARRANGEMENT	19
10.3.1	EXPANSION VESSEL SIZING	19
10.4	DE-STRATIFICATION.....	19
10.5	INTEGRAL PUMP	19
11.0	ELECTRICAL SUPPLY	20
11.1	CONNECTOR STRIP.....	20
11.2	FUSES	21
11.3	ARC WELDING PRECAUTIONS	21
11.4	ANCILLARY EQUIPMENT	21
11.4.1	RCW CONTROLLER	21
11.5	WIRING DIAGRAMS	22
12.0	COMMISSIONING AND TESTING	24
12.1	ELECTRICAL INSTALLATION	24
12.2	GAS INSTALLATION	24
12.3	WATER CONNECTIONS	24
12.4	COMMISSIONING THE EQUIPMENT	24
12.4.1	GENERAL CHECKS PRIOR TO LIGHTING	24
12.4.2	EQUIPMENT CHECKS PRIOR TO LIGHTING	24
12.4.3	PROCEDURE FOR INITIAL LIGHTING	24
12.4.4	GAS PRESSURE ADJUSTMENT AND COMBUSTION CHECKS	25
12.5	TEMPERATURE ADJUSTMENT PROCEDURE	26
12.6	INSTALLATION NOISE	26
13.0	LPG FUEL	26
13.1	RELATED DOCUMENTS	26
13.2	CONVERSION AND COMMISSIONING PROCEDURE	26
14.0	MAINTENANCE	27
14.1	GENERAL	27
14.2	MAINTENANCE SCHEDULE	27
14.3	BURNER INSPECTION	28
14.4	BURNER REMOVAL.....	28
14.5	CLEANING THE HEAT EXCHANGER.....	28
14.6	DRAINING THE WATER HEATER	29
14.7	REMOVING SCALE AND SEDIMENT FROM THE STORAGE VESSEL.....	29
14.8	REFILLING THE SYSTEM	29
14.9	OTHER CHECKS.....	29
14.9.1	RELIEF VALVES (IF FITTED).....	29
14.9.2	FLUE SYSTEM.....	30
14.10	TROUBLESHOOTING	31
14.10.1	FAULTS AND COMPLAINTS	31
14.10.2	POSSIBLE CAUSES.....	31
14.10.3	SOLUTIONS.....	32
15.0	ErP SPECIFICATION DATA SHEET.....	32
16.0	USER INSTRUCTIONS.....	32

1.0 DISPLAY CODES

The Lochinvar EcoForce++ has a three digit LED display on the front panel; this display is used for setting the desired stored water temperature and for aiding diagnosis for why the unit is not firing.

1.1 DOUBLE NUMBERS

If two numbers (e.g. 60) are displayed, the water heater is operating normally and the value displayed is the setpoint of the water heater. If the green LED below the display is illuminated, this signifies that the burner is active.

1.2 DIAGNOSTIC CODES

When a code is permanently displayed (i.e. not flashing), the water heater is waiting for a specific condition before beginning the firing sequence. The following table gives a list of diagnostic codes, descriptions of the fault and solutions.

Code	Fault	Solution
A2	Outlet temperature too high	Wait for outlet temperature to drop.
A6	Fan speed too high	Wait for fan speed to drop
A7	Fan speed too low	Wait for fan speed to increase
A8	Water flow through heater too low	Wait for water flow to increase
C1	Flame simulation	Wait for burner to extinguish
C3	High limit thermostat activated	Wait for water temperature to drop
E6	Heater running in safe operation mode	Contact Lochinvar Limited

TABLE 1.1 DIAGNOSTIC CODES

1.3 ERROR CODES

When a code is flashing in the LED display, the water heater has locked out and will need to be reset by depressing the button on the heater control panel. The following table gives a list of error codes, descriptions of the causes and solutions.

Code	Fault	Solution
F0	Short Circuit in Ionisation Circuit	Check position of ionisation probe
F2	High temperature limit exceeded	Check water flow through water heater
F4	Wrong Fan speed	Check control wiring to fan
F5	No Flame after 5 Ignition attempts	Check incoming gas pressure
F6	Flame lost (4 times) during Running	Check condition of flue joints
E0	Outlet sensor shorted or interrupted	Check internal wiring
E2	Inlet sensor shorted or interrupted	Check internal wiring
E6	Low water flow (A8) has occurred 4 times	Check operation of integral pump
H1	Gas valve wiring interrupted	Check internal wiring

TABLE 1.2 ERROR CODES

2.0 INTRODUCTION

- The Lochinvar EcoForce++™ range is a floor standing direct gas-fired condensing water heater. The equipment comprises a stainless steel radial burner assembly and heat exchanger that permits fully condensing operation, a stainless steel storage vessel, a bronze circulating pump and interconnecting pipework between the storage vessel and heat exchanger.
- The burner is initiated by a full electronic ignition sequence control that incorporates a spark ignition and a flame rectification device for supervision of the flame.
- The output from the water heater is regulated by a variable speed combustion fan and gas/air ratio controls to maintain the correct combustion at all levels of modulation. This configuration allows modulation down to 25% of the rated output.
- For the correct operation of the water heater, an integral pump is utilised to maintain a constant water flow rate through the heat exchanger.
- This equipment is intended for use on Group H Natural Gas (2nd Family) and LPG propane (3rd Family). The information relating to propane firing is to be found in **Section 13: LPG FUEL**. This equipment **MUST NOT** use gas other than that for which it has been designed and adjusted.
- This equipment must be installed by a competent person, registered with a H.S.E. approved body. All installations must conform to the relevant Gas Safety and Building Regulations. Health & Safety requirements must also be taken into account when installing any equipment. Failure to comply with the above may lead to prosecution.
- If the equipment is to be connected to an unvented (pressurised) system, care must be taken to ensure all extra safety requirements are satisfied should a high or low-pressure condition occur in the system.
- The equipment is designed for direct connection to a flue system.
- **Ancillary Options:**
 - Unvented/Boosted Water System Kit WH17
 - Condensate Neutralisation Kit KIT2000
 - De-stratification Pump Kit WH9
 - RCW Controller E04-016-354
 - Flue System Components Contact Lochinvar Limited

2.1 PRINCIPAL PARTS

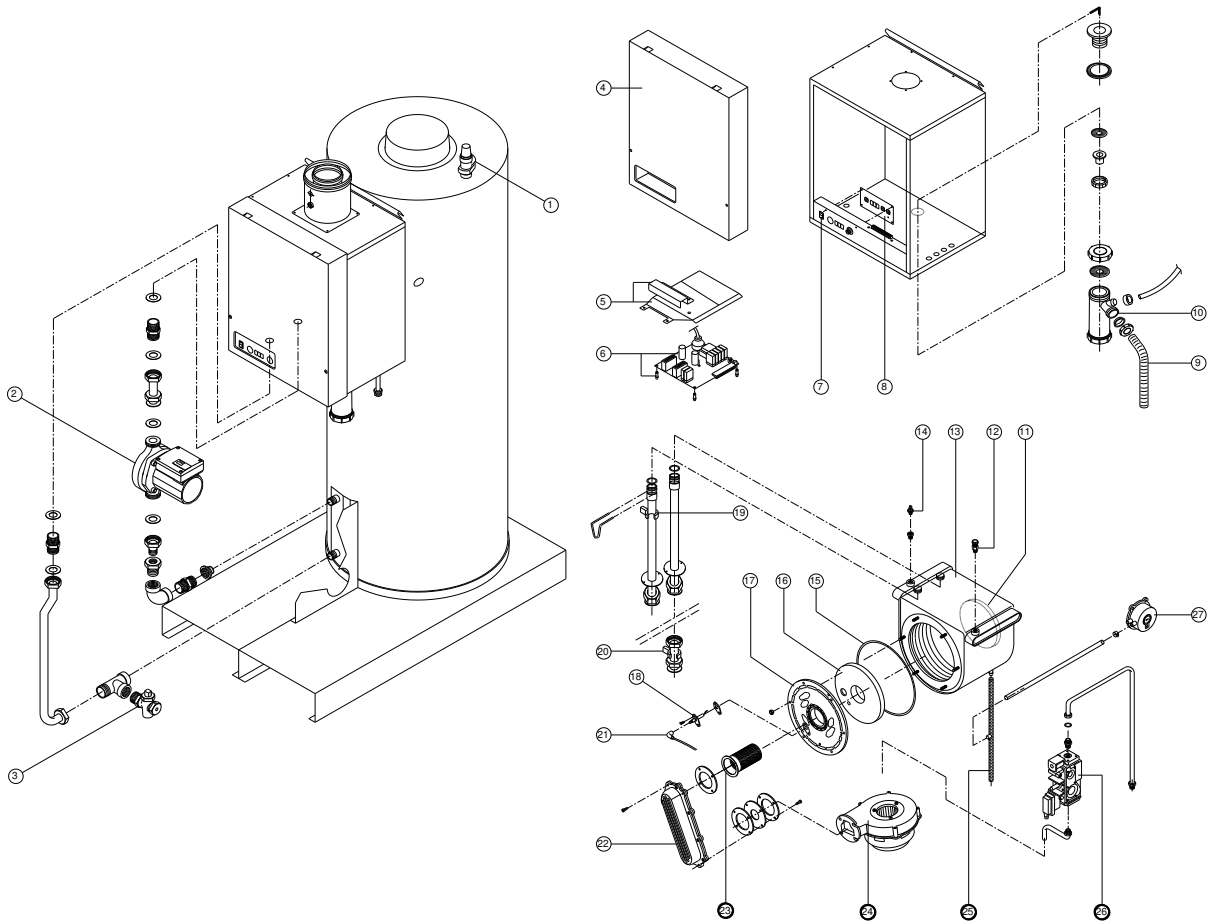

FIGURE 2.1 PRINCIPAL PARTS

1	Temperature and pressure relief valve	15	Burner door seal
2	Pump	16	Burner door insulation
3	Drain valve	17	Burner door
4	Front cover	18	Ignition and flame sense electrode
5	Burner control cover	19	Outlet sensor
6	Burner control	20	Inlet sensor
7	Power switch	21	Electrode cap
8	Display PCB	22	Gas/air duct
9	Condensate drain pipe	23	Burner
10	Condensate trap	24	Combustion fan
11	Combustion chamber rear wall insulation	25	Condensate drain tube
12	Air vent	26	Gas valve
13	Heat exchanger	27	Air pressure switch
14	High limit thermostat		

TABLE 2.1 PRINCIPAL PARTS

3.0 TECHNICAL DATA

GENERAL			
Product Identification Number	CE 0063		
Classification	II ₂ H3P		
Gas Appliance Type	B ₂₃ , C ₁₃ , C ₂₃ , C ₃₃ , C ₄₃ , C ₈₃		
WATER DATA			
MODEL NUMBER	EF+35/150+	EF+35/230+	EF+55/230+
Water Content (Litres)	150	230	230
Shipping Weight (Kg)	97	114	117
Water Connection (B.S.P.)	1 ½		
Gas Connection (B.S.P.)	¾		
Flue Size (Concentric) (mm)	80/125		
Flue Size (Conventional) (mm)	80		
Power Consumption (Watts)	300	330	
Protection Class	IP40		
HOT WATER SUPPLY			
MODEL NUMBER	EF+35/150+	EF+35/230+	EF+55/230+
Nominal Input (Net) (kW)	6.8-34.0		10.6-53.0
Nominal Input (Gross) (kW)	7.5-37.7		11.8-58.8
Efficiency 50/30°C Low Fire (%)	108		107
NOx emission (mg/kWh)	<15		
CO emission (mg/kWh)	<20		
Max. recovery @ 44°C (l/hr)	716		1110
Max. recovery @ 50°C (l/hr)	630		977
Max. recovery @ 56°C (l/hr)	563		872
TECHNICAL DETAILS			
Average Flue Gas Temperature (°C)	80		
Minimum Draught Requirements (mbar)	-0.03 to -0.10		
CO ₂ – Flue gas (G20) (%)	9.0		
Gas Flow Rate (G20) (m ³ /hr)	3.6		5.6
Flue Gas Mass Rate (G20) (g/sec)	13.7		21.4
CO ₂ – Flue gas (G31) (%)	10.0		
Gas Flow Rate (G31) (m ³ /hr)	1.5		2.3
Flue Gas Mass Rate (G31) (g/sec)	14.1		21.9
Waterside pressure loss (@ 15K ΔT) (m WC)	6.0		7.5
Max. Outlet Temp. (°C)	75		
Operating Pressure min./max. (bar)	0.2 – 5.5*		

TABLE 3.1 TECHNICAL DATA

*For Un-Vented systems only, Vented systems 8 bar

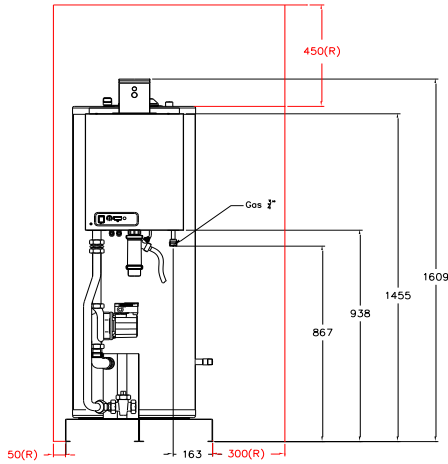
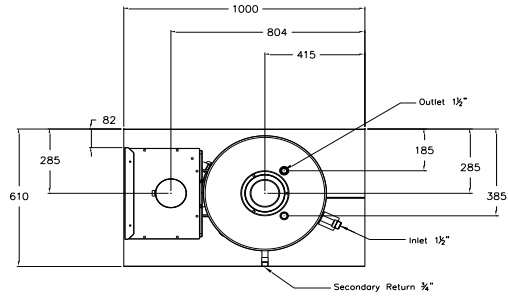
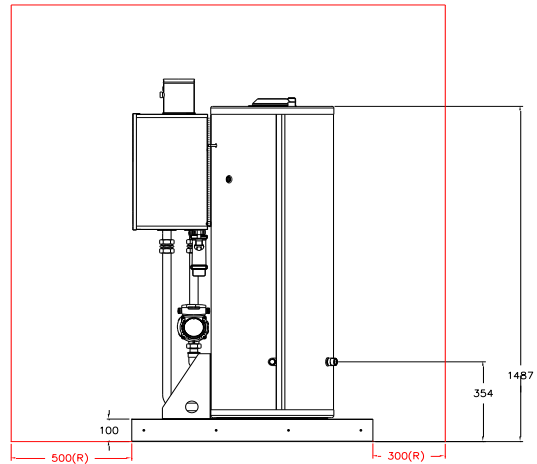

FIGURE 3.1



DIMENSIONS EF+35/150+

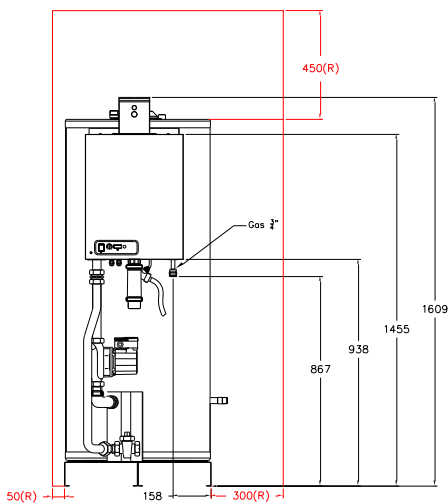
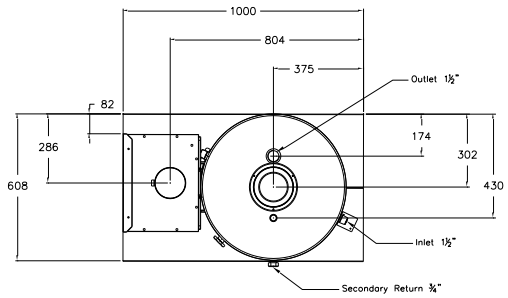
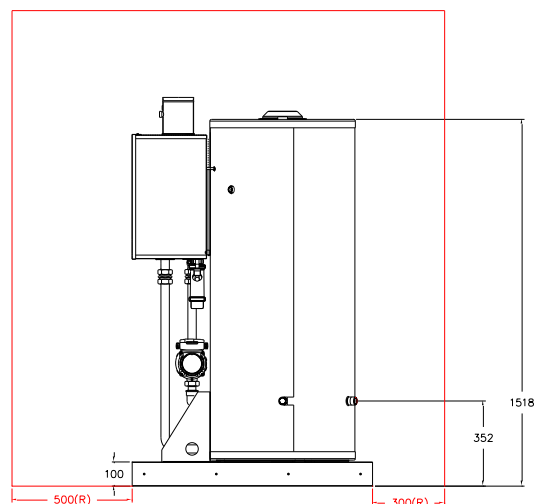

FIGURE 3.2



DIMENSIONS EF+35/230+ & EF+55/230+

NOTE: Dimensions marked (R) are recommended clearances to allow for pipework and flue connections during the installation process.

4.0 GENERAL REQUIREMENTS

The Lochinvar EcoForce++ condensing water heater has been designed to operate trouble free for many years. These instructions should be followed closely to obtain the maximum usage and efficiency of the equipment. **PLEASE** read the instructions fully before installing or using the appliance.

4.1 RELATED DOCUMENTS

It is law that all gas appliances are installed by competent persons, in accordance with The Gas Safety (Installation and Use) Regulations 1998. Failure to install appliances correctly could lead to prosecution. It is in your own interest, and that of safety, to ensure that this law is complied with.

The installation of the equipment **MUST** be in accordance with the relevant requirements of the Gas Safety Regulations, Building Regulations, I.E.E. Regulations and the bylaws of the local water undertaking. The installation should also be in accordance with any relevant requirements of the local gas distributor and local authority.

In addition the installation should follow the relevant guidance offered in the following documents. It is not practical to list all relevant information but emphasis is placed on the following documents, as failure to comply with the guidance given will almost certainly result in an unsatisfactory installation:

BS 5440-1: 2008 Installation and maintenance of flues and ventilation for gas appliances of rated input not exceeding 70kW net (1st, 2nd and 3rd family gases)
Part 1: Specification for installation and maintenance of flues

BS 5440-2: 2009 Installation and maintenance of flues and ventilation for gas appliances of rated input not exceeding 70kW net (1st, 2nd and 3rd family gases)
Part 2: Specification for installation and maintenance of ventilation for gas appliances

BS 6644: 2005
+ A1: 2008 Specification for Installation of gas-fired hot water boilers of rated inputs between 70kW (net) and 1.8MW (net) (2nd and 3rd family gasses)

BS 6700: 1997 Design, installation, testing and maintenance of services supplying water for domestic use within buildings and their curtilages

BS 6880: 1988
Parts 1, 2 and 3 Code of practice for low temperature hot water systems of output greater than 45kW

BS 7074: 1989
Parts 1 and 2 Application, selection and installation of expansion vessels and ancillary equipment for sealed systems

BS 7671: 2008 Requirements for electrical installations, I.E.E. wiring regulations seventeenth edition

CP 342:
Part 2 1974 Code of practice for centralised hot water supply- buildings other than dwellings

IGE/UP/1:
Edition 2 Installation pipework on industrial and commercial premises

IGE/UP/2:
Edition 2 Gas installation pipework, boosters and compressors on industrial and commercial premises

IGE/UP/4:
Edition 2 Commissioning of gas-fired plant on industrial and commercial premises

IGE/UP/10:
Edition 3 Installation of flued gas appliances in industrial and commercial premises

Gas Safety (Installation and Use) Regulations 1998 (England, Scotland & Wales)

CIBSE: Guide parts A, B and C

H.S.E. guidance Automatically controlled steam and hot water boilers
note PM5:

Third edition of the 1956 Clean Air Act Memorandum on Chimney Heights

Manufacturer's notes must not be taken in any way as overriding statutory obligations.

5.0 WATER QUALITY

Water supply quality may adversely affect the efficiency and performance of water heaters and hot water systems. The situation can intensify where higher temperatures or demands exist.

Water hardness should not exceed 205ppm CaCO₃ and TDS (Total Dissolved Solids) of untreated water should not exceed 350ppm. If these values are exceeded, contact Lochinvar Limited for further guidance.

6.0 LOCATION

6.1 PLANT ROOM REQUIREMENTS

The Lochinvar EcoForce++ may only be installed in a room that complies with the appropriate ventilation requirements.

The Lochinvar EcoForce++ can be used as a type C₁₃, C₂₃, C₃₃ C₄₃ or C₈₃ appliance. Due to its room sealed design, ventilation allowances for combustion air are not necessary. If the appliance is to be installed in a compartment or a hot environment, ventilation for cooling purposes must be fitted. For further guidance, please refer to **Section 9: AIR SUPPLY** or to **BS5440-2** or **BS6644** as appropriate.

The Lochinvar EcoForce++ can also be used as a type B₂₃ appliance. If such a configuration is to be used, then appropriate ventilation for cooling and combustion must be provided. For further details, please refer to **Section 9: AIR SUPPLY** or to **BS5440-2** or **BS6644** as appropriate.

6.2 GENERAL REQUIREMENTS

Corrosion of the heat exchanger coils and flue system may occur if air for combustion contains certain chemical vapours. Such corrosion may result in poor combustion and create a risk of asphyxiation. Aerosol propellants, cleaning solvents, refrigerator and air conditioning refrigerants, swimming pool chemicals, calcium and sodium chloride, waxes and process chemicals are corrosive. Products of this sort should not be stored near the water heater or outside by the air intake (if applicable). The fitting of this equipment in a situation where aerosols or other chemicals may be entrained into the combustion air will invalidate the warranty.

The equipment must be installed on a level surface that is capable of adequately supporting its weight (when filled with water) and any ancillary equipment. The operation of the equipment must not cause the temperature of any combustible material in the vicinity of the equipment and its flue to exceed 65°C. If such a situation is unavoidable, appropriate insulation should be provided.

Locate the equipment so that if the appliance or any connecting pipework should leak, water damage will not occur. When such locations cannot be avoided it is recommended that a suitable drain pan be installed under the equipment. The pan should be adequately drained but must not restrict the combustion or ventilation airflow.

6.3 CLEARANCES

The location chosen for the equipment must permit the provision for a satisfactory flue system and, where necessary, an adequate air supply. The location must also provide adequate space for servicing and air circulation around each unit. This includes any electrical trunking laid across the floor and to the appliance.

See **Figure 3.1** and **Figure 3.2** for dimensions/clearances. Further details regarding locations are given in **BS5440** or **BS6644** as appropriate.

6.4 CONDENSATE DRAIN

The condensate drain is located in the centre of the water heater underside. It is fitted with a $\frac{3}{4}$ " flexible hose that should be connected to an appropriate condensate drain, sloping continuously away from the water heater at an angle of at least 3° (50mm per metre).

The Water Resources Act requires that trade effluent is discharged to municipal sewers between pH 6.5 and 10.0. If it is determined that these levels cannot be achieved, an in-line condensate neutralisation kit is available as an ancillary option from Lochinvar Limited. This unit is capable of neutralising 4000 litres of condensate to a pH of 7.0 before releasing it to a drain.

7.0 GAS SUPPLY

The Lochinvar EcoForce++ range is suitable for use on second and third family gasses 2H - G20 - 20mbar and 3P - G31 - 37mbar. Details relating to Natural Gas (2H) appear below; **for details relating to Propane (3P) please refer to Section 13: LPG FUEL.**

7.1 SERVICE PIPES

The local gas distributor must be consulted at the installation planning stage in order to establish the availability of an adequate supply of gas. An existing service pipe must not be used without prior consultation with the local gas distributor.

7.2 METERS

A new gas meter will be connected to the service pipe by the local gas distributor contractor. An existing gas meter should be checked, preferably by the gas distributor, to ensure that it is adequate to deal with the rate of gas supply required.

7.3 GAS SUPPLY PIPES

Supply pipes must be fitted in accordance with **IGE/UP/2**. Pipework from the meter to the equipment must be of adequate size. The complete installation must be purged and tested as described in **IGE/UP/1**. Refer to **Section 13: LPG FUEL** for information on LPG pipework installation guidance.

7.4 BOOSTED SUPPLIES

Where it is necessary to employ a gas pressure booster, the controls must include a low-pressure cut-off switch at the booster inlet. The local gas distributor must be consulted before a gas pressure booster is fitted.

7.5 PLANT-ROOM CONTROL VALVE

A manual valve for plant-room isolation must be fitted in the gas supply line. It must be clearly identified and readily accessible for operation, preferably by an exit.

7.6 EQUIPMENT GAS SYSTEM LEAK CHECK

An approved gas inlet appliance isolating valve and union should be installed for each unit in a convenient and safe position and be clearly marked. Ensure that the gas inlet appliance isolating valve is in the OFF position. Although the equipment receives a gas leak check and gas train component integrity check prior to leaving the factory, transit and installation may cause disturbance to unions, fittings and components. During commissioning a further test for tightness should be carried out on the equipment gas pipework and components.

Care must be taken not to allow leak detection fluid on or near any electrical parts or connections.

8.0 FLUE SYSTEM

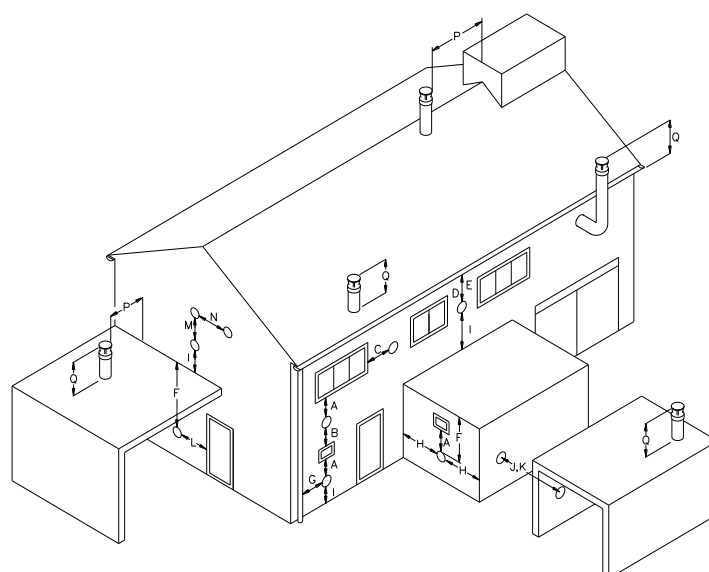

FIGURE 8.1: FLUE TERMINAL POSITIONS

Location	Description	Distance
A	Directly below an opening, air brick, opening windows etc.	300
B	Above an opening, air brick, opening windows etc.	300
C	Horizontally to an opening, air brick, opening windows etc.	300
D	Below a gutter or sanitary pipework	75
E	Below the eaves	200
F	Below a balcony or car port roof	200
G	From a vertical drain or soil pipe	150
H	From an internal or external corner	300
I	Above ground, roof or balcony level	300
J	From a surface facing the terminal	600
K	From a terminal facing the terminal	1200
L	From an opening in the car port (e.g. door, window) into the dwelling	1200
M	Vertically from a terminal on the same wall	1500
N	Horizontally from a terminal on the same wall	300
P	From a vertical structure on the roof	300
Q	Above intersection with the roof	300

TABLE 8.1 FLUE TERMINAL MINIMUM DISTANCES

8.1 FLUE SYSTEM GENERAL REQUIREMENTS

Detailed recommendations for the flue system are given in **BS5440-1** for equipment of rated input not exceeding 70kW net, **BS6644** for equipment above 70kW net and **IGE/UP/10** for equipment of rated input above 54kW net. The following notes are intended to give general guidance only.

8.2 APPROVED FLUE SYSTEM

The approved flue system is not suitable for use external to the building. If external routes cannot be avoided, a flue system manufacturer should be consulted to supply a suitable alternative.

The heater is supplied for connection to a concentric flue system. If conventional flue is to be used, a conversion kit will be required. Contact Lochinvar Limited for further details.

When used as a Type C (Balanced Flued) appliance, the approved, purpose designed adaptive concentric flue system should be used. When used as a Type B (Conventional Flued) appliance, a suitable flue system constructed of Stainless Steel or Polypropylene with a temperature rating in excess of 120°C should be used. **Aluminium flue pipe must not be used on this appliance as it may lead to premature failure of the heat exchanger and will invalidate the warranty.**

Flue kits are supplied separately, please refer to EcoForce™ Flueing Specification or contact Lochinvar Limited for further details.

8.3 INSTALLATION PRECAUTIONS

- The approved flue system is rated to 120°C max.
- The heater must not be operated unless the complete flue system is installed. This includes the water heater connections, flue pipes, and terminal. If discharging at low level, a suitable flue guard must be installed.
- Due to the condensing nature of the water heater, long external runs should be avoided to prevent the condensate freezing within the flue system.
- During assembly of the flue system, precaution should be taken to ensure that the internal sealing ring is seated correctly.
- Due to the close tolerances in the flue system, it may be necessary to use a twisting action to fit the joints together. No lubrication other than water should be used.

8.4 MAXIMUM LENGTH – CONCENTRIC FLUE

The maximum length of the flue system is determined by the resistance of the components within the flue. **The resistance must not exceed 200Pa.**

	EF+35/150+ EF+35/230+	EF+55/230+
Wall terminal	6	11
Roof terminal	13	25
Straight tube (m)	5	10
45° Elbow	3	5
90° Elbow	5	10

TABLE 8.2 CONCENTRIC FLUE COMPONENT RESISTANCES (Pa)

8.4.1 WORKED EXAMPLE – CONCENTRIC FLUE

EF+35/230+ water heater terminating vertically with a flue run of 10 metres plus 2 x 90° elbows.

Item	Quantity	Resistance	Total
Wall terminal	0	6	0
Roof terminal	1	13	13
Straight tube (m)	10	5	50
45° Elbow	0	3	0
90° Elbow	2	5	10
Total Resistance (Pa)			73

TABLE 8.3 CONCENTRIC FLUE WORKED EXAMPLE

The total resistance of 73 Pa is less than the 200 Pa maximum value therefore this is acceptable.

8.5 MAXIMUM LENGTH – CONVENTIONAL FLUE

The maximum length of the flue system is determined by the resistance of the components within the flue. **The resistance must not exceed 150Pa.**

	EF+35/150+ EF+35/230+	EF+55/230+
Terminal	6.0	11.0
Straight tube (m)	3.0	6.6
45° Elbow	1.7	4.3
90° Elbow	3.1	7.5

TABLE 8.4 CONVENTIONAL FLUE COMPONENT RESISTANCES (Pa)

8.5.1 WORKED EXAMPLE – CONCENTRIC FLUE

EF+55/230+ water heater terminating vertically with a flue run of 16 metres plus 4 x 90° elbows.

Item	Quantity	Resistance	Total
Terminal	1	11.0	11.0
Straight tube (m)	16	6.6	105.6
45° Elbow	0	4.3	0
90° Elbow	4	7.5	30
Total Resistance (Pa)			146.6

TABLE 8.5 CONVENTIONAL FLUE WORKED EXAMPLE

The total resistance of 146.6 Pa is less than the 150 Pa maximum value therefore this is acceptable.

8.6 FLUE DISCHARGE

The flue system must ensure safe and efficient operation of the equipment to which it is attached, protect the combustion process from wind effects and disperse the products of combustion to open external air.

Under certain operating and weather conditions, the EcoForce++ water heater may generate a plume at the terminal. Consideration should be given to the nuisance this may cause and the terminal should be sited accordingly.

The flue must terminate in a freely exposed position and be so situated as to prevent the products of combustion entering any opening in a building. For further information on terminal locations, please refer to **Figure 8.1**.

8.7 FLUE TERMINAL INSTALLATION

8.7.1 TYPE B₂₃ (CONVENTIONAL FLUE)

The details of how to convert the appliance for conventional flued operation are contained within the conversion kit.

When the heater is installed as a Type B₂₃ appliance, the flue system should be installed in accordance with the flue manufacturer's specific instructions.

8.7.2 TYPE C₁₃ (HORIZONTAL BALANCED FLUE)

When the heater is installed as a Type C₁₃ appliance, the flue system should be installed as follows:

1. Determine the location of the flue terminal, taking into account minimum distances as detailed in **Figure 8.1, Table 8.1** and the relevant British Standards.
2. Taking care to protect the appliance from debris and dust, drill a hole in the desired location. The diameter of the hole should be no more than 10mm greater than the diameter of the air supply pipe of the terminal.
3. Determine the required length of the terminal and cut as necessary.

NOTE: When determining the required length for the flue terminal, the outer wall plate or rosette should be flush to the wall. (See Figure 8.6)

NOTE: Once cut; remove all burrs and sharp edges.

4. Insert the terminal into the drilled hole. The terminal section should be installed level or with a fall to outside (Max. 10mm per metre) to prevent the ingress of water.

NOTE: When inserting the terminal, ensure the air intake section is at the bottom.

5. Fill the void between the terminal and wall with water resistant sealant.
6. Fit the wall plates or rosette using appropriate fixings.
7. Install the remainder of the flue system working progressively away from the water heater supporting the pipes as necessary.

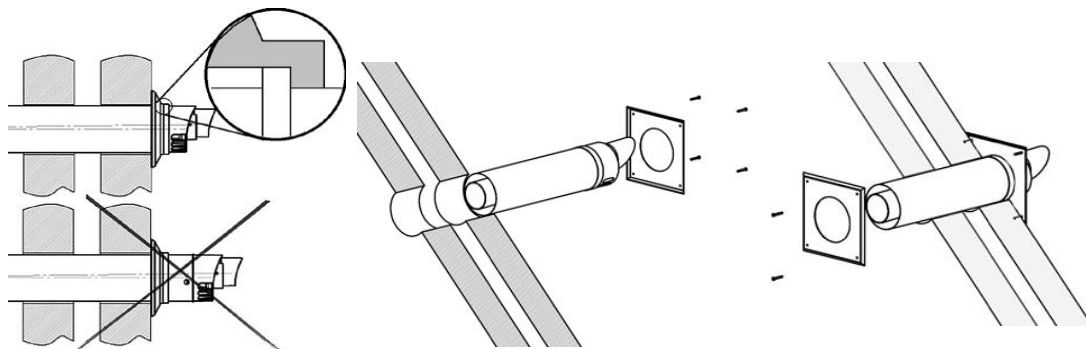

FIGURE 8.6 HORIZONTAL TERMINAL INSTALLATION

8.7.3 TYPE C₃₃ (VERTICAL BALANCED FLUE)

When the heater is installed as a Type C₃₃ appliance, the flue system should be installed as follows:

1. Confirm that the roof flashing is correct for the type of roof through which the terminal is to be installed. (See **Figure 8.7**)
2. Determine the desired location for the flue terminal, taking into account minimum distances as detailed in **Figure 8.1, Table 8.1** and the relevant British Standards.
3. Taking care to protect the appliance from debris and dust, drill a hole in the desired location. The diameter of the hole should be no more than 10mm greater than the diameter of the air supply pipe of the terminal.

NOTE: The hole should be drilled from the outside to ensure that no damage is done to the roofing material. Extra care should be taken to ensure that the hole is drilled vertically.

4. Install the roof flashing and secure as appropriate.
5. Carefully insert the roof terminal through the roof flashing and hole in the roof.

NOTE: When inserting the roof terminal do not support or turn the terminal using the cap.

6. Ensure the terminal is vertical using a spirit level.
7. Fit the support bracket around the terminal and secure using appropriate fixings. Do not tighten the support bracket.
8. Install the remainder of the flue system working progressively away from the water heater supporting the pipes as necessary.
9. Once the flue system is fully installed, tighten the clamp to secure the terminal in place.

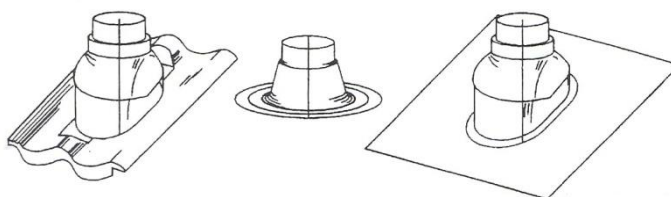

FIGURE 8.7 VERTICAL TERMINAL ROOF FLASHINGS FOR SYNTHETIC, FLAT AND TILED ROOFS

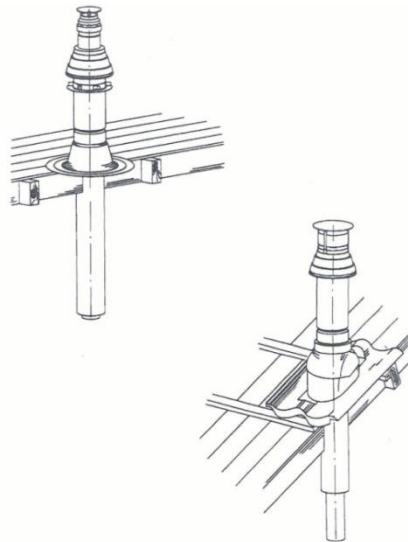

FIGURE 8.8 INSTALLING TERMINAL THROUGH ROOF FLASHING

8.8 FLUE TERMINAL GUARDING

If a horizontal flue terminal is to be fitted less than 2 metres from ground level or in a location where it can be touched from a window, door or balcony, a terminal guard must be fitted. An approved terminal guard is available; please contact Lochinvar Limited for further information.

The terminal guard should be positioned centrally around the terminal and secured using appropriate wall fixings.

8.9 CONDENSATE DRAIN

For flue runs of less than 6 metres, provided that the flue system rises at an angle of at least 3° (50mm per metre), no additional condensate drain will be required. Failure to provide an adequate rise in the flue system may lead to pooling of condensate which may lead to premature failure of the flue system.

If the flue run is greater than 6 metres, it is recommended that an inline condensate drain and trap are fitted. The condensate trap should be connected to a suitable drainage system as described in **Section 6.4: CONDENSATE DRAIN**.

9.0 AIR SUPPLY

The following information is based on single water heater installations only. If more than one water heater is being used, **BS5440-2** or **BS6644** (as appropriate) should be consulted to calculate the necessary requirements.

9.1 COMBUSTION VENTILATION

When used as a Type C appliance, ventilation for combustion is not necessary as the combustion air is ducted directly from outside.

When used as a Type B appliance, the combustion air requirements are as follows:

Model	Input (Gross) kW	Input (Net) kW	Ventilation (Room) (cm ²)	Compartment (Direct to Outside) (cm ²)		Compartment (To Internal Space) (cm ²)	
				High	Low	High	Low
EF+35/150+	37.7	34.0	135	170	340	340	680
EF+35/230+	37.7	34.0	135	170	340	340	680
EF+55/230+	58.8	53.0	230	265	530	530	1060

TABLE 9.1 COMBUSTION VENTILATION REQUIREMENTS

9.2 COOLING VENTILATION

When used as a type C appliance, installed in a compartment or an enclosure, cooling ventilation should be provided as follows:

Model	Input (Gross) kW	Input (Net) kW	Enclosure/Compartment (Direct to Outside)		Enclosure/Compartment (To Internal Space)	
			High (cm ²)	Low (cm ²)	High (cm ²)	Low (cm ²)
EF+35/150+	37.4	34.0	170	170	340	340
EF+35/230+	37.4	34.0	170	170	340	340
EF+55/230+	58.8	53.0	265	265	530	530

TABLE 9.2 COOLING VENTILATION REQUIREMENTS

When used as a type B appliance, provision for cooling ventilation is included in the combustion ventilation allowance.

10.0 WATER CONNECTIONS

10.1 INSTALLATION SCHEMATIC DRAWINGS

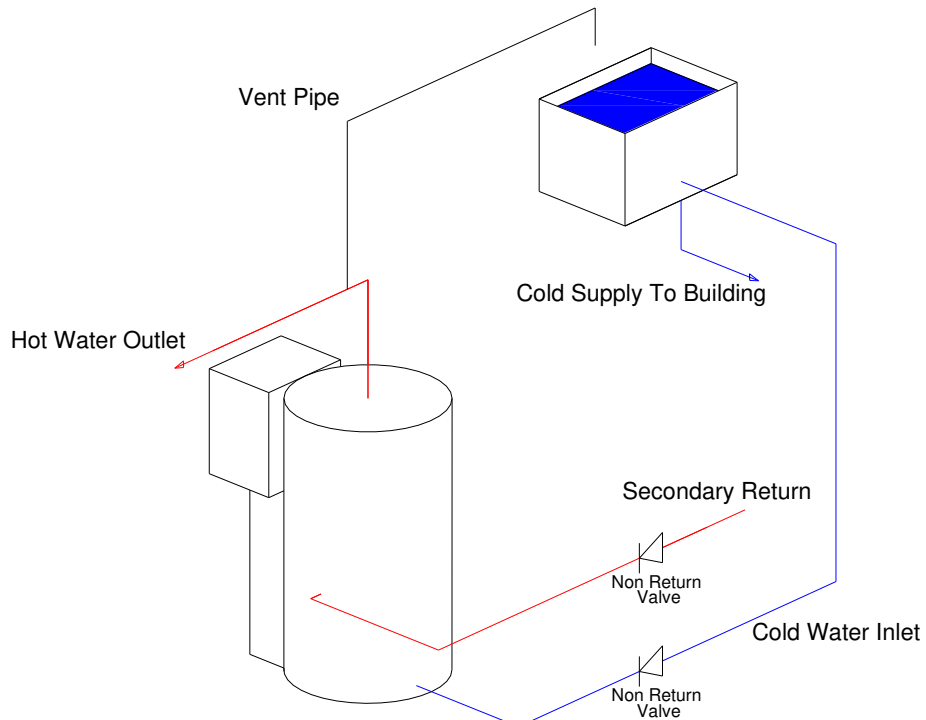

FIGURE 10.1 1 X ECOFORCE++ - OPEN VENTED SUPPLY

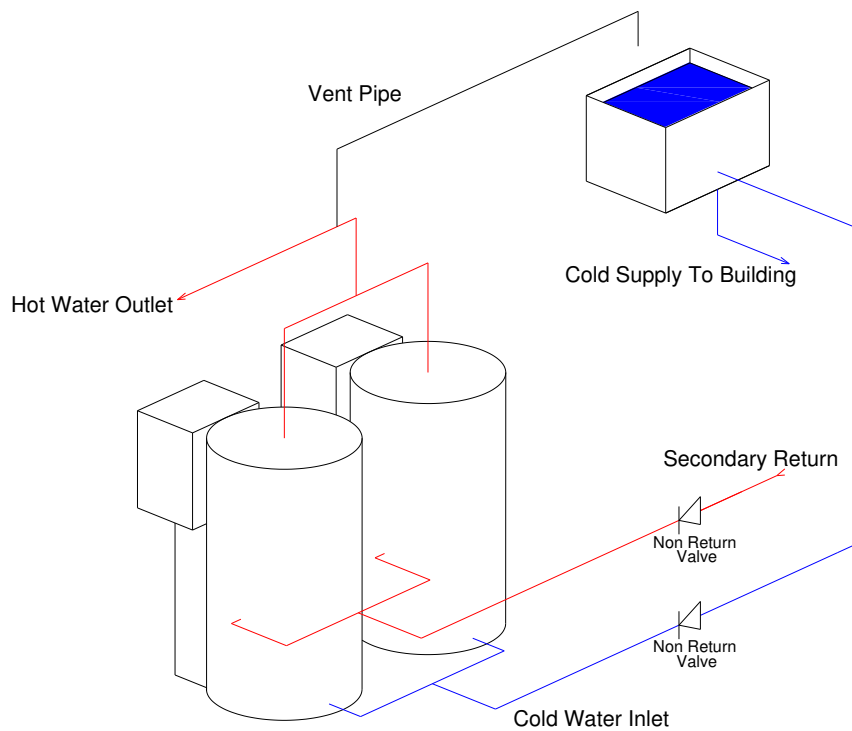

FIGURE 10.2 2 X ECOFORCE++ - OPEN VENTED SUPPLY

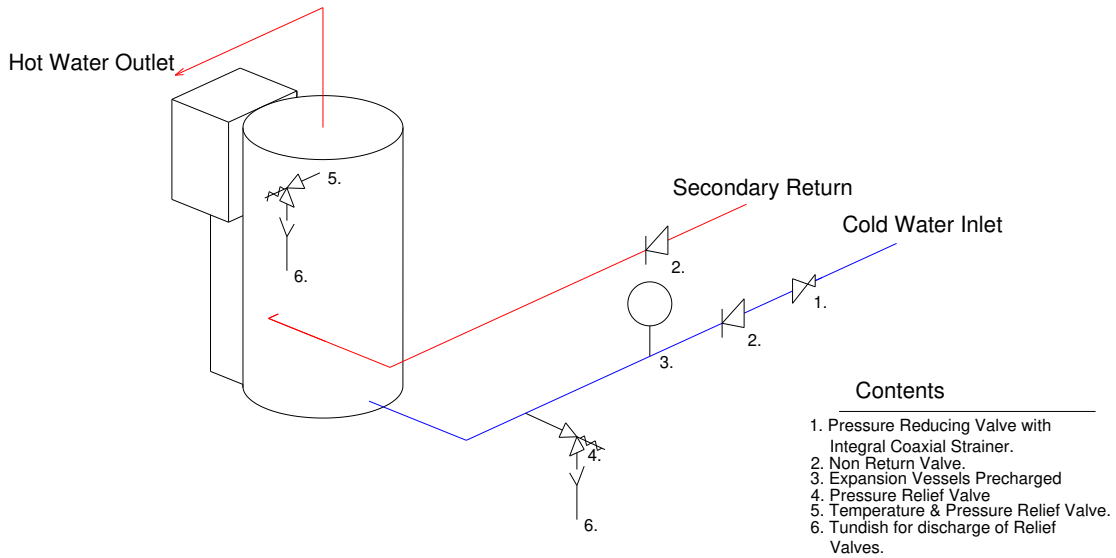

FIGURE 10.3 1 X ECOFORCE++ - UNVENTED SUPPLY

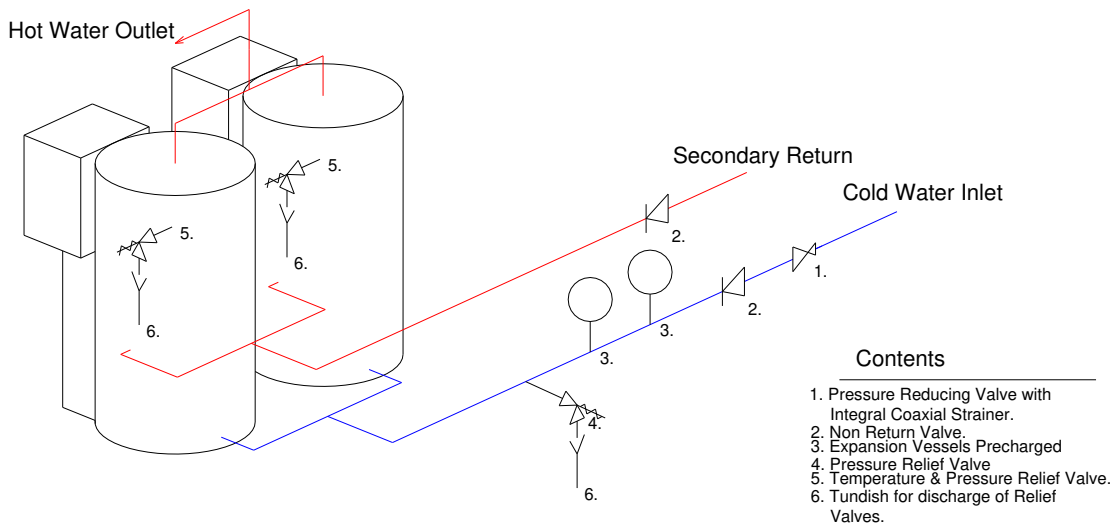

FIGURE 10.4 2 X ECOFORCE++ - UNVENTED SUPPLY

These installation schematic drawings are given only as examples. Should your application be different, Lochinvar Limited would be able to provide you with a suitable schematic. Please contact us for details.

It is recommended that isolation valves are fitted to the cold-water inlet and hot water draw off connections to aid in any routine maintenance work that needs to be carried out.

This appliance has 1 1/2" B.S.P. water connections. Cold water supply should be made into the connection at the back of the storage vessel and hot water draw off should be taken from the connection on the top of the storage vessel.

10.2 OPEN VENTED SYSTEM ARRANGEMENT

The Lochinvar EcoForce++ can be used in an open vented arrangement provided that a vent pipe in accordance with **CP 342**, **BS6644** or **BS6700** as appropriate is fitted. The minimum static head requirement for an open vented system is 0.2 bar. For further details, please refer to **Figure 10.1** and **Figure 10.2**.

10.3 UNVENTED SYSTEM ARRANGEMENT

NOTE: IT IS STRONGLY RECOMMENDED THAT UNVENTED HOT WATER SYSTEMS BE INSTALLED BY AN APPROVED INSTALLER.

If the Lochinvar EcoForce++ is to be used in an unvented arrangement, the system should follow the guidance given in **BS6700** and must comply with the **Building Regulations 1992: Part G3, in England and Wales, P5 in Northern Ireland and P3 in Scotland**. A kit of components that have been suitably sized for the unvented operation of the appliance is available from Lochinvar Limited. For further information, contact Lochinvar Limited.

10.3.1 EXPANSION VESSEL SIZING

The following information is based on an inlet pressure of 3.5 bar. If a different inlet pressure is to be used, please consult **BS6700**.

$$V V = \frac{S V * e}{0.45}$$

Where:

V V = Vessel Volume
 S V = System Volume
 e = Coefficient of Expansion (See **Table 10.1**)

Stored Temp. °C	30	35	40	45	50	55	60
e	0.005	0.006	0.008	0.010	0.012	0.015	0.017
Stored Temp. °C	65	70	75	80	82	85	90
e	0.020	0.023	0.026	0.030	0.031	0.033	0.037

TABLE 10.1 COEFFICIENT OF EXPANSION OF WATER AT 3.5 BAR INLET PRESSURE

10.4 DE-STRATIFICATION

If the hot water system does not include a constantly circulated building return, it is recommended that a de-stratification pump be fitted, between the flow connection and the circulation connection on the right hand side of the storage vessel, to ensure an even temperature distribution throughout the stored water. De-stratification pump kits are available from Lochinvar Limited as an ancillary option.

10.5 INTEGRAL PUMP

The unit is fitted with an integral pump sized to give the correct water flow through the heat exchanger. This is adjusted to its highest setting. **Do not adjust this setting.** If the water flow through the heat exchanger drops and the temperature differential is too high, the water heater will shut down until the differential drops. If this situation occurs more than four times, the water heater will lock out. Upon resetting the water heater, the output will be limited to 50% in order to protect the heat exchanger. If this situation occurs, please contact Lochinvar Limited for further guidance.

11.0 ELECTRICAL SUPPLY

Wiring external to the equipment must be installed in accordance with the I.E.E. Regulations and any local regulations that apply.

Model	Normal Supply Voltage	External Fuse Rating	Power Consumption
EF+35/150+	230V AC 50 Hz 1 PH	6.0 A	300 W
EF+35/230+			300 W
EF+55/230+			330 W

TABLE 11.1 ELECTRICAL SUPPLY REQUIREMENTS

WARNING: THIS APPLIANCE MUST BE EARTHED

A suitably competent person MUST check wiring. Normal supply required is 230 volts AC, single phase, 50 Hz. An isolator with a contact separation of at least 3mm in all poles should be sited close to the equipment and must only serve that equipment. The double pole switch must be readily accessible under all conditions.

11.1 CONNECTOR STRIP

1	2	3	4	5	6	7	8	9	10	11	12	13	14	15	16	17	18	19	20
EXTERNAL SENSOR		+	-	REMOTE CONTROL		+	-	OUTSIDE SENSOR		LOCK-OUT SIGNAL		HEAT DEMAND SIGNAL		L	⏚	N	L	⏚	N
		CASCADE CONNECTION				0-10 VDC								PUMP 230V AC 1PH 50Hz			POWER SUPPLY 230V AC 1PH 50Hz		

FIGURE 11.1 CONNECTOR STRIP

PIN	CONNECTION	NOTES
1&2	External Sensor	If desired, a sensor or thermostat can be placed in the storage vessel. When the temperature in the storage vessel drops below the set point, the heat source will fire. If a sensor is used, the heat source will operate in its full modulating mode. If a thermostat is used, the heat source will operate in a limited on-off mode. This external sensor is not required for the EcoForce++ to operate correctly.
3&4	Cascade Connection	This function is not used on the EcoForce++
5&6	Remote Control	The EcoForce++ has an OpenTherm® Bus connection for connecting a modulating time and temperature controller. An example of this is the RCW controller available from Lochinvar Limited. Features include: <ul style="list-style-type: none"> • Start up optimisation • Three timer programs • Remote fault code display If the "Open-Therm" control system is not used, terminals 5&6 need to be linked. If external time control is required, a volt-free contact can be used to break this link. For further information, please refer to Section 11.4.2: RCW CONTROLLER
7&8	0-10 VDC	The heat source can be controlled by an analogue interface from a Building Management System (BMS). If the input is less than 1 Volt, the heat source will not fire, between 1 Volt and 9.5 Volts the setpoint is adjusted within its operating range. If the input is greater than 9.5 Volts, the heat source will fire at maximum setpoint. The 0-10 VDC cannot be used in conjunction with an "Open Therm" controller.
9&10	Outside Temperature Sensor	This function is not used on the EcoForce++
11&12	Lock-Out Signal	A volt free contact built into the control board that will close in the event of a lock-out.
13&14	Heat Demand Signal	A volt free contact built into the control board that will close when the burner initiation cycle is completed
15-17	Pump	Power supply for the integral circulating pump. This connection is made at the time of manufacture.
18-20	Power Supply	The permanent supply should be made to these connections as follows: Pin 18 Live Pin 19 Earth Pin 20 Neutral Connections must only be made using appropriate diameter multi-strand flexible cables. Cable entry must be made via the cable gland located on the under side of the heat source.

TABLE 11.2 CONNECTION TERMINAL DETAILS

11.2 FUSES

The EcoForce++ has four internal fuses. Three will automatically reset, the fourth is rated at 3.15 A, and is located at the rear of the main control board.

11.3 ARC WELDING PRECAUTIONS

The appliance must be isolated from the mains electricity supply in the event of electric arc welding being carried out on any connecting pipework.

11.4 ANCILLARY EQUIPMENT

11.4.1 RCW CONTROLLER

The RCW controller should be installed in accordance with the separate installation guide. The connection between the water heater and controller should be made using screened two core cable.

In order for the RCW controller to work correctly, the following modification to the heater wiring must be undertaken:

1. Isolate the incoming electrical supply to the appliance.
2. Loosen the two retaining screws and remove the front cover from the appliance.
3. Remove the retaining screws and remove the burner control PCB cover from the appliance.
4. Trace the yellow wires from the "Remote Control" terminals (pin 5 & 6) of the connection strip to the transition plug and socket (see **Figure 11.2**).
5. Disconnect the transition plug and socket and fit the plug to the blue socket on the burner control PCB (see **Figure 11.2**).
6. Fit the bridging plug (**Figure 11.3**) to the transition socket.
7. Refit the burner control PCB to the appliance.
8. Refit the front cover to the appliance.

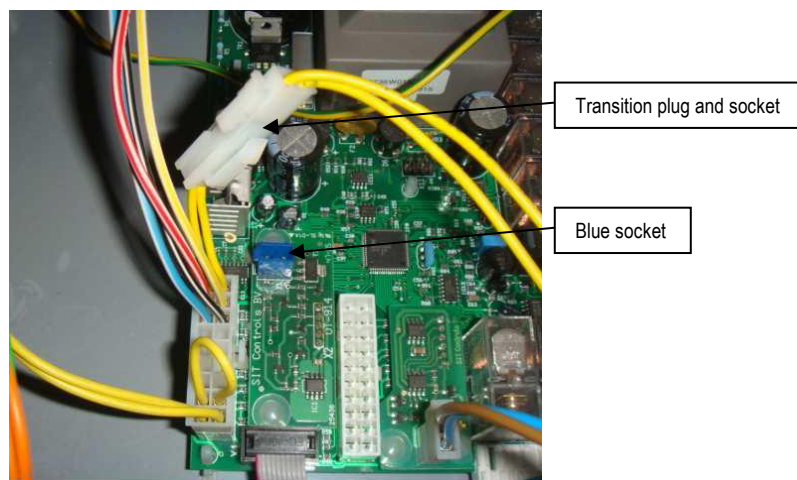

FIGURE 11.2 RCW WIRING MODIFICATIONS

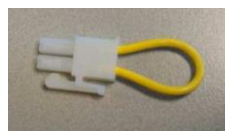

FIGURE 11.3 BRIDGING PLUG

11.5 WIRING DIAGRAMS

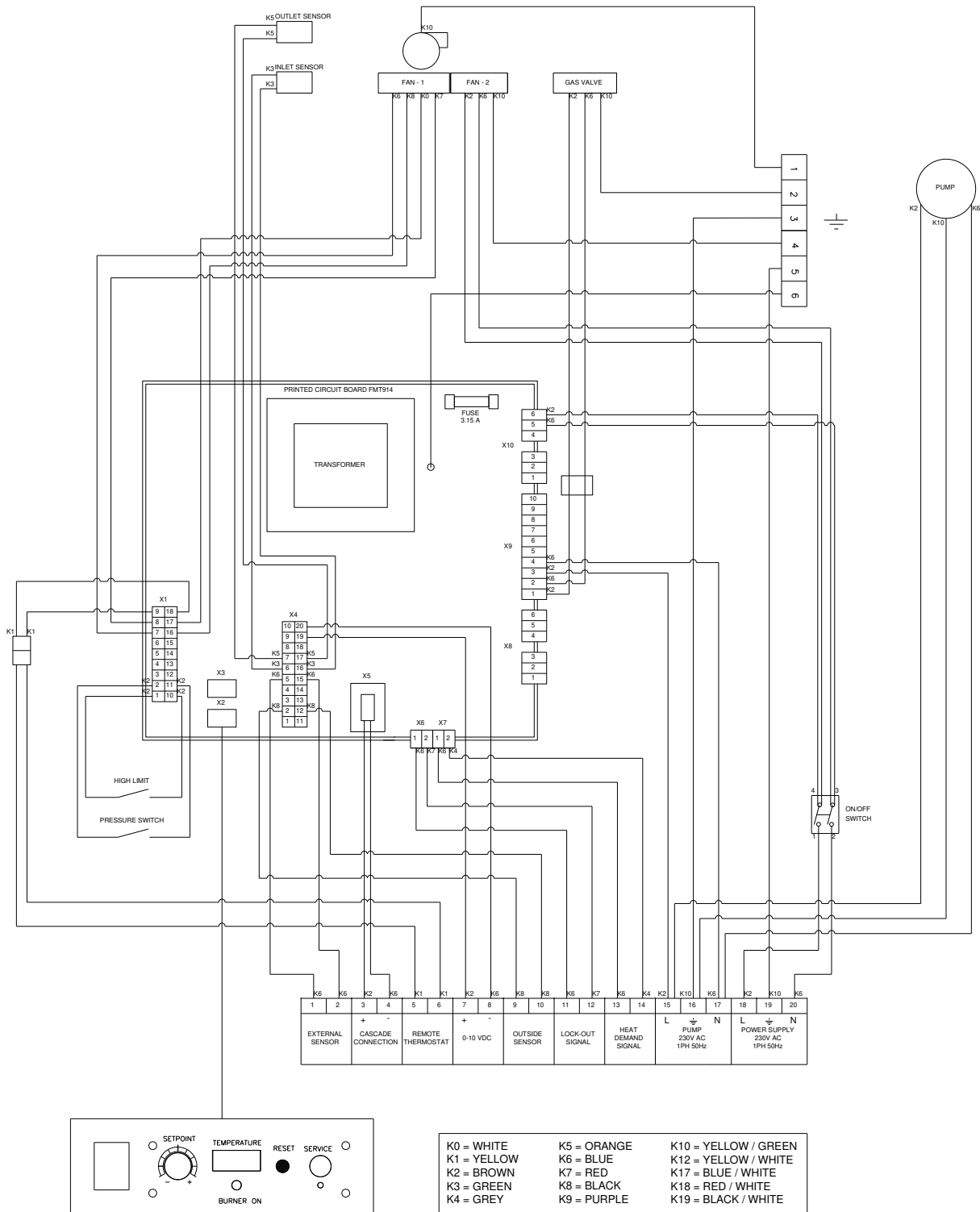

FIGURE 11.4 STANDARD WIRING DIAGRAM

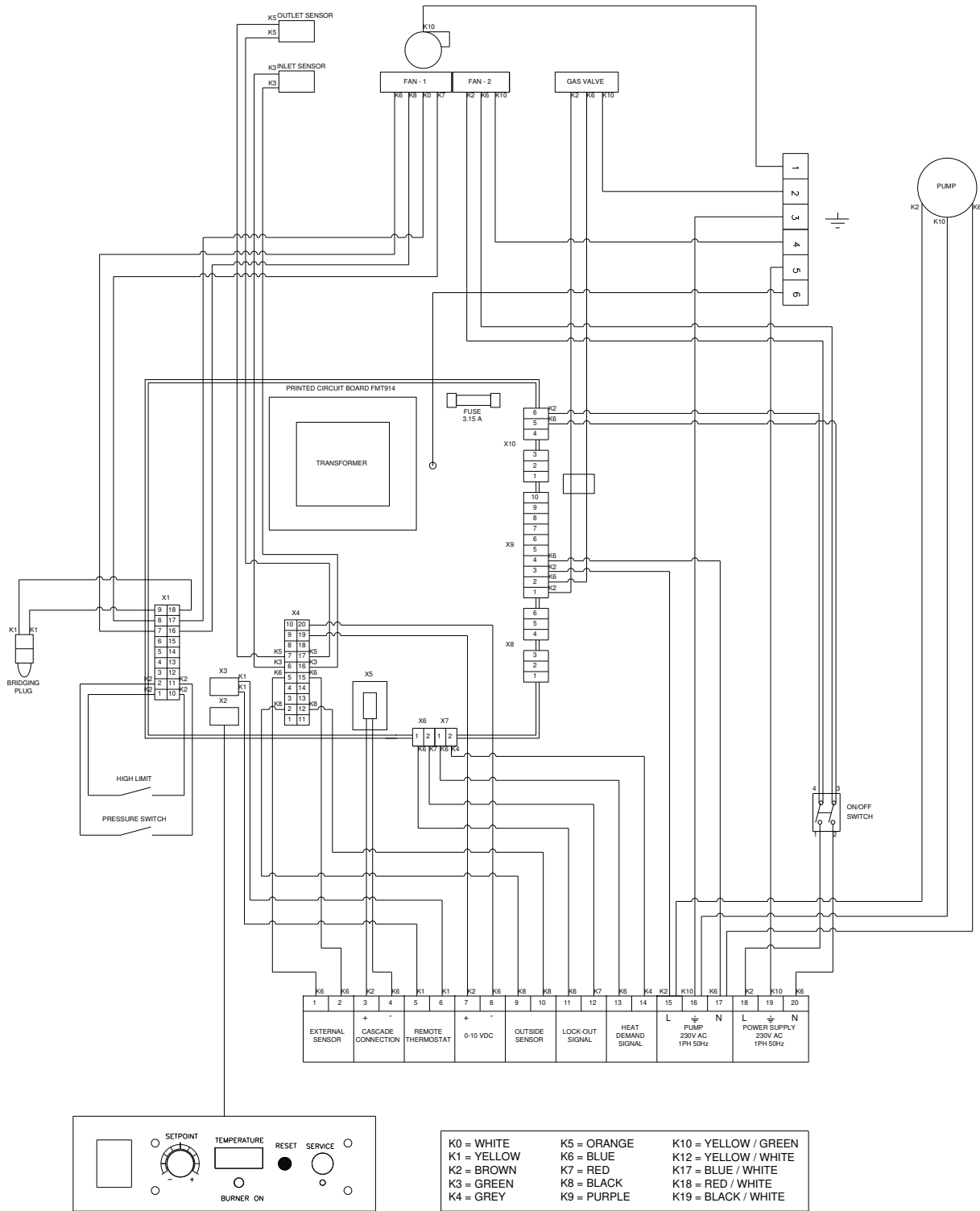

FIGURE 11.5 RCW MODE WIRING DIAGRAM

12.0 COMMISSIONING AND TESTING

12.1 ELECTRICAL INSTALLATION

Notes on the requirements for electrical installation are provided in **Section 11: ELECTRICAL SUPPLY**. A schematic drawing of the control circuit is shown in **Figure 11.4** and **Figure 11.5**.

12.2 GAS INSTALLATION

For design see **Section 7: GAS SUPPLY**. See **Figure 3.1** and **Figure 3.2** for details on the position of the gas connection.

12.3 WATER CONNECTIONS

For design see **Section 10: WATER CONNECTIONS**

The system should be thoroughly flushed out with cold water without any circulating pump in position. Ensure all the valves are open.

If a return pump is to be fitted, it should be fitted before the system is filled and air locks cleared. Check the system for leaks and repair as necessary. If the system is configured in an unvented arrangement, check the expansion vessel cushion pressure.

12.4 COMMISSIONING THE EQUIPMENT

12.4.1 GENERAL CHECKS PRIOR TO LIGHTING

A person deemed competent MUST be responsible for the commissioning of this equipment. Before attempting to commission any equipment, ensure that personnel involved are aware of what action is about to be taken and begin by making the following checks:

1. Flueway passages are clear.
2. Adequate ventilation exists in the plant room (if necessary).
3. The system is fully charged with water, ready to receive heat. All necessary valves are open and the building return pump (if fitted) is circulating water.
4. The gas supply pipework is clear of any loose matter, tested for soundness and purged.
5. The condensate drain is installed correctly and the condensate trap is filled with water.

NOTE: If the condensate trap is not filled before use, products of combustion may escape and can lead to severe personal injury or death

12.4.2 EQUIPMENT CHECKS PRIOR TO LIGHTING

This unit has been designed for a nominal gas inlet pressure of 20 mbar when used on natural gas. Information relating to propane firing can be found in Section 13: LPG FUEL

1. Gas supply is connected but turned to the "off" position. Any unions or fittings are correctly tightened, test points are closed and the ignition electrode lead is connected correctly. Ensure the ceramic sheath around the ignition electrode is not cracked or broken.
2. Ensure electricity supply is connected.
3. Check that the integral circulating pump is fully bled.

12.4.3 PROCEDURE FOR INITIAL LIGHTING

IF THE UNIT IS TO OPERATE ON LPG REFER TO SECTION 13.2 BEFORE PROCEEDING

1. Ensure that the gas inlet appliance isolating valve, provided by the installer, is in the "off" position.
2. Press the power rocker switch, positioned on the front of the appliance next to the control thermostat, to bring the equipment on.

3. Depress the recessed button located below the computer interface port to place the water heater into service mode.
4. The combustion fan should ramp up to full speed to purge the combustion chamber and then drop back to half rate in order to light. The spark generator should create a spark, visible through the burner sight glass. As the gas inlet appliance isolating valve is closed, the controls should go to a flame failure condition after four ignition attempts.
5. If the above occurs correctly, open the gas inlet appliance isolating valve, reset the unit by depressing the button on the control panel and place the water heater back in to service mode.
6. The combustion fan will repeat the pre-purge procedure and attempt to light. Once a flame is established, the green 'Burner On' lamp, located below the digital display on the control panel, will illuminate.
7. Depress the service mode button again to shut the water heater down. Once this has been done, check that the main flame has extinguished.

12.4.4 GAS PRESSURE ADJUSTMENT AND COMBUSTION CHECKS

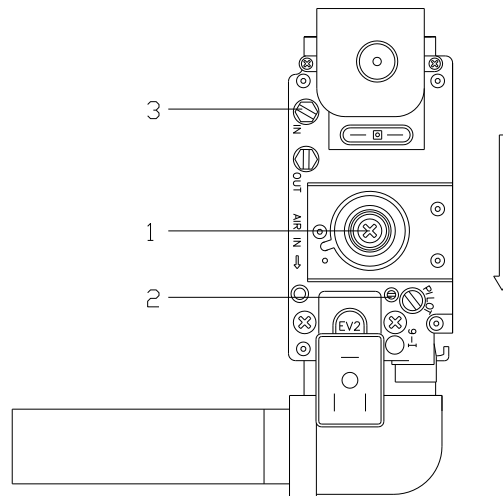

FIGURE 12.1 GAS VALVE

The most effective way of setting the heat source is through the use of a CO₂ measuring device such as a combustion analyser. The procedure is as follows:

1. Put the water heater into 'Service Mode'. This is done by depressing the small switch located below the communication interface port.
2. Turn the set point dial fully clockwise, this should ramp the fan up to its maximum speed.
3. Adjust screw 2 to give a CO₂ output of 8.8% ($\pm 0.3\%$). Turning the screw clockwise will reduce the CO₂ level, turning anti-clockwise will increase the CO₂ level.
4. Turn the set point dial fully anti-clockwise, this should ramp the fan down to its minimum speed.
5. Adjust screw 1 to give a CO₂ output of 8.5% ($\pm 0.3\%$). Turning the screw clockwise will increase the CO₂ level, turning anti-clockwise will reduce the CO₂ level.
6. Turn the set point dial fully clockwise and re-check the combustion reading at high fire. Adjust as necessary.
7. Once the setting has been completed, depress the small switch below the communication interface port to return the water heater to its normal operating mode.
8. Record the combustion data and leave with the appliance for future reference.

Combustion figures for Propane firing can be found in **Section 13: LPG FUEL**.

12.5 TEMPERATURE ADJUSTMENT PROCEDURE

The setpoint should be adjusted to ensure that the water is stored at 60°C and distributed at 50°C within 1 (one) minute at all outlets. Care is needed to avoid much higher temperatures because of the risk of scalding. At 50°C the risk of scalding is small for most people, but the risk increases rapidly with higher temperatures and for longer exposure times. The risk to young children and to those with a sensory or mobility loss will be greater. Where a significant scalding risk has been identified, the use of thermostatic mixing valves on baths and showers should be considered to reduce temperature, these need to be placed as close to the point of use as possible.

12.6 INSTALLATION NOISE

If care has been taken to follow the manufacturer's instructions there should be no discernible noise from the equipment. The allied pump motor may have a level of sound that could lead to consideration for acoustic insulation, but care must be taken not to impede ventilation or airflow to the pump motor.

13.0 LPG FUEL

NOTE! IT IS STRONGLY RECOMMENDED THAT, ON LPG INSTALLATIONS, GAS DETECTION EQUIPMENT IS FITTED. THIS EQUIPMENT SHOULD BE POSITIONED NEAR THE APPLIANCE AND AT LOW LEVEL. IT IS ALSO IMPORTANT THAT THE SPACE HOUSING THE APPLIANCE IS ADEQUATELY VENTILATED AT HIGH AND LOW LEVEL. THIS APPLIANCE MUST NOT BE LOCATED BELOW GROUND E.G. IN A CELLAR.

13.1 RELATED DOCUMENTS

In addition to those documents listed in **Section 4.1: RELATED DOCUMENTS** within the main body of the installer's guide the gas installation should also comply with the guidance offered in the following documents.

BS 5482-1: 2005 Code of practice for domestic butane and propane gas burning installations.
Part 1: Installations at permanent dwellings, residential park homes and commercial premises, with installation pipework sizes not exceeding dn25 for steel and dn28 for corrugated stainless steel or copper.

The operation of the EcoForce++ range on LPG-Propane (3rd Family) 3P is similar to that on Natural Gas (2nd Family) 2H and the design and installation details described in the main body of the installer's guide should be followed.

13.2 CONVERSION AND COMMISSIONING PROCEDURE

This process must be carried out in the order stated when the water heater is switched on for the first time. Failure to follow the following procedure may lead to non-warrantable damage to the water heater.

Due to the design of the water heater, the conversion to LPG-Propane requires adjustment of the gas valve only (see **Figure 13.1**). The sequence is as follows:

1. Ensure that the gas inlet appliance isolating valve, provided by the installer, is in the "off" position.
2. Press the power rocker switch, positioned on the front of the appliance next to the control thermostat, to bring the equipment on.
3. Depress the recessed button located below the computer interface port to place the water heater into service mode.
4. The combustion fan should ramp up to full speed to purge the combustion chamber and then drop back to half rate in order to light. The spark generator should create a spark, visible through the burner sight glass. As the gas inlet appliance isolating valve is closed, the controls should go to a flame failure condition after four ignition attempts.
5. Isolate the electrical supply to the appliance. Turn screw 2 clockwise until the screw stops then turn anti-clockwise through two full turns.
6. Turn on the main power to the water heater, press the reset button and place the unit into service mode.
7. If the water heater does not fire after three ignition attempts, turn screw 2 through a further half turn anti-clockwise.
8. Turn the set point dial fully clockwise, this should ramp the fan up to its maximum speed.

9. Adjust screw 2 to give a CO₂ output of 9.8% (\pm 0.3%). Turning the screw clockwise will reduce the CO₂ level, turning anti-clockwise will increase the CO₂ level.
10. Turn the set point dial fully anti-clockwise, this should ramp the fan down to its minimum speed.
11. Adjust screw 1 to give a CO₂ output of 9.5% (\pm 0.3%). Turning the screw clockwise will increase the CO₂ level, turning anti-clockwise will reduce the CO₂ level.
12. Turn the set point dial fully clockwise and re-check the combustion reading at high fire. Adjust as necessary.
13. Once the setting has been completed, depress the small switch below the communication interface port to return the water heater to its normal operating mode.
14. Record the combustion data and leave with the appliance for future reference.

NOTE: The dust cap, once reinstalled, should be marked with an anti-tamper indicator.

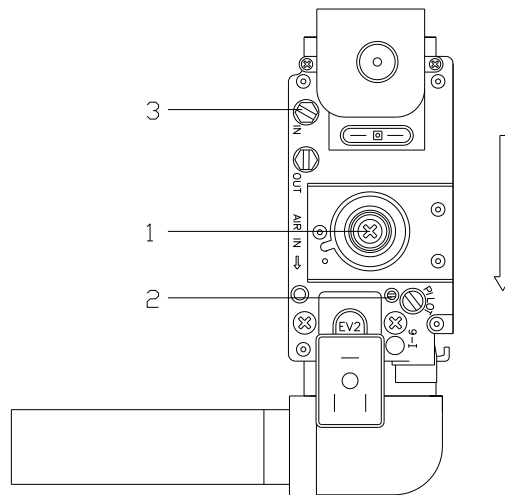

FIGURE 13.1 GAS VALVE

14.0 MAINTENANCE

14.1 GENERAL

KEEP APPLIANCE AREA CLEAR AND FREE FROM COMBUSTIBLE MATERIALS AND FLAMMABLE VAPOURS AND LIQUIDS.

A competent person registered for working on non-domestic gas appliances should check and ensure that the flue, its support and terminal, the ventilation to the plant room, safety valve, drain, pressure gauge etc. are in a serviceable and working condition and still comply with the relevant standards and codes of practice, as detailed in **Section 4: GENERAL REQUIREMENTS**.

Servicing is recommended at intervals no greater than 12 months to ensure trouble free operation. Even if the maintenance schedule for the storage vessel is determined to be less than annually, it is important that all controls and safety features are checked for correct operation on an annual basis.

Measuring flue gas CO₂ and flue gas temperatures will give an indication of the state of the flue and burner. Results of the flue gas analysis should be compared with previously measured values to identify any changes in operational characteristics.

14.2 MAINTENANCE SCHEDULE

Waterborne impurities consist of the particles of soil and sand, which can settle out and form a layer of sediment on the bottom of the allied storage vessel. The amount of calcium carbonate (scale) released from water is in direct proportion to water temperature and usage. The higher the water temperature or water usage, the more scale deposits are dropped out of the water.

Scale accumulation not only reduces the life of the equipment but also reduces efficiency of the water heater and increases fuel consumption. The usage of water softening equipment greatly reduces the hardness of the water. However, this equipment does not always remove all of the hardness (scale). For this reason it is recommended that a regular schedule of de-scaling be maintained.

14.3 BURNER INSPECTION

The heat exchanger has a sight glass for inspection of the flame picture.

NOTE: If the appliance has been in recent operation, this area may be hot. Appropriate precautions should be taken to prevent personal injury.

To check the flame picture at high and low fire, the following procedure should be used:

1. Place the water heater into service mode. This is done by depressing the small button below the computer interface port.
2. The heater should shut down and relight.
3. Turn the temperature adjustment thumbwheel fully clockwise, this should ramp the water heater up to maximum rate.
4. Check the flame condition.
5. Turn the temperature adjustment thumbwheel fully counter-clockwise, this should ramp the water heater down to minimum rate.
6. Check the flame condition.
7. Press the service button to take the unit out of service mode.

14.4 BURNER REMOVAL

If it has been determined that the flame picture is unacceptable, the burner can be removed and cleaned using the following procedure:

1. Isolate the electrical and gas supplies to the heater.
2. Allow the boiler to cool down.
3. Disconnect the wiring connections to the ignition electrode.
4. Disconnect the power and control connection leads and earthing wire from the combustion fan.
5. Apply a suitable release oil to the 6 studs around the edge of burner door.
6. Remove the 6 retaining nuts around the edge of the burner door.

NOTE: Once loosened, the nuts should be removed by hand. If any of the nuts seize, the nut should gently be re-tightened and additional release oil used.

7. Withdraw the heat exchanger front plate and burner assembly from the heat exchanger complete with the combustion fan.
8. With the burner assembly away from the boiler, the burner can be gently cleaned with the brush attachment of a vacuum cleaner.

The reassembly procedure is the reverse of the above taking care to ensure that the for the heat exchanger front plate sealing gasket, the combustion fan connection gasket, the burner door insulation and the combustion chamber rear wall insulation are in good condition or are replaced as necessary.

NOTE: PARTICULAR ATTENTION SHOULD BE PAID TO THE COMBUSTION CHAMBER REAR WALL INSULATION. IF ANY DETERIORATION IN THE INSULATING MATERIAL IS NOTED, THE INSULATION PANEL MUST BE REPLACED.

14.5 CLEANING THE HEAT EXCHANGER

To clean the heat exchanger, the following procedure should be carried out:

1. Remove the burners as above.
2. Use a vacuum cleaner to remove any accumulation on the heating surfaces.
3. Inspect the heat exchanger to ensure that the 1 mm flueway is clear between all coils.
4. If any debris is still present, brush the heat exchanger with a non-metallic brush taking care not to damage the insulation panel on the rear wall of the heat exchanger.

NOTE: A kit of components to aid with cleaning the heat exchanger (part number KIT30063) is available from Lochinvar Limited.

NOTE: It is very important to inspect and remove all deposits from the heat exchanger. If all deposits cannot be removed from the heat exchanger, contact Lochinvar Limited for further guidance.

5. Once the heat exchanger has been brushed it should be rinsed with fresh water to remove all residues.
6. Remove the condensate water trap and clean out any debris.
7. Refit the condensate drain and fully recharge by pouring 1 litre of water through the heat exchanger coils.
8. Reinstall the burner.
9. Restart the heater as detailed in **Section 12.4.3: PROCEDURE FOR INITIAL LIGHTING**.

14.6 DRAINING THE WATER HEATER

The water heater must be drained if it is to be shut down and exposed to freezing temperatures. Maintenance and service procedures may also require draining the water heater.

1. Turn off the water heater electrical disconnect switch.
2. Connect a hose to the drain valve on the storage vessel.
3. Locate hose's discharge in an area where hot water will not cause any damage or injury.
4. Close the cold water inlet valve to the storage vessel.
5. Open a nearby hot water outlet to vent the system.
6. Open the drain valve.
7. Once the system has been drained, the heat exchanger can be purged of water using an air compressor.
8. If the water heating system is being drained for an extended shutdown, it is suggested the drain valve be left open during this period.

14.7 REMOVING SCALE AND SEDIMENT FROM THE STORAGE VESSEL

1. Drain the water system. Refer to **Section 14.6 DRAINING THE WATER HEATER**.
2. Remove outer cover plate from top of storage vessel jacket.
3. Remove cover and gasket from cleanout opening.
4. Remove scale or sediment using care not to damage the cold water injection system.
5. Inspect cleanout plate gasket and replace if necessary.
6. Install gasket and cleanout plate.

14.8 REFILLING THE SYSTEM

1. Close the drain valve on the storage vessel.
2. Open a hot water fixture to allow air to escape.
3. Open the cold water supply to water heating system and allow it to fill.
4. Isolate the gas supply to the heater and reinstate the electrical supply.
5. Once there is no air left in the heat exchanger (e.g. no air bleeding from the auto air vent), follow the lighting instructions as detailed in **Section 12.4.3: PROCEDURE FOR INITIAL LIGHTING**.
6. Check for water leakage.

14.9 OTHER CHECKS

14.9.1 RELIEF VALVES (IF FITTED)

At least once a year, the temperature and pressure relief valve and safety valve should be checked to ensure that they are in operating condition. To check each valve, lift the lever or turn the screw cap at the end of the valve several times. The valve should operate freely and seat properly.

If water does not flow, remove and inspect for obstructions or corrosion. Replace with a new valve of the recommended size as necessary.

14.9.2 FLUE SYSTEM

Examine the exhaust and air intake system at least once a year. Points of inspection are as follows:

1. Check for obstructions and/or deterioration of flue piping and terminal. Replace immediately where needed.
2. Check the terminal for any foreign material and remove as necessary.
3. Check all flue system connections for leakage and reseal as required.
4. Check that ventilation grilles comply with current regulations.

14.10 TROUBLESHOOTING

The following tables give lockout codes and common complaints concerning the operation of the water heater, possible causes of the fault and solutions.

14.10.1 FAULTS AND COMPLAINTS

Code	Fault	Possible causes
F0	Short Circuit in Ionisation Circuit.	11; 18;
F2	High temperature limit exceeded	1; 2; 14; 17; 24
F4	Wrong Fan speed.	3; 4; 5; 9; 19; 20; 21
F5	No Flame after 5 Ignition attempts.	6; 7; 10; 11; 13; 15; 18
F6	Flame lost (4 times) during Running.	6; 8; 10; 13; 15; 16; 22
E0	Outlet sensor shorted or interrupted	1; 2; 14; 17; 24
E2	Inlet sensor short or interrupted.	1; 2; 14; 17; 24
H1	Gas valve wiring interrupted.	12

TABLE 14.1 ERROR CODES

Complaint	Possible causes
The sanitary water is not warming up; water heater is working.	23; 26; 27
Noisy ignition.	10; 18
Water heater fires continuously but the water is not getting hot.	23
Temperature of the water is too hot.	25; 28
Temperature of the water is too cold.	25; 29
Noisy operation.	14

TABLE 14.2 COMMON COMPLAINTS

14.10.2 POSSIBLE CAUSES

1	Pump seized.
2	Water pressure in the system too low.
3	Fan power cable unplugged.
4	Fan impeller dirty.
5	Fan is defective.
6	Gas supply isolated.
7	Gas supply pressure is too low.
8	Gas supply pipe too small.
9	Blown fuse.
10	Gas valve setting for minimum fan speed incorrect.
11	Ignition cable incorrectly connected.
12	Connecting plug to gas valve connected incorrectly.
13	Condensate drain blocked.
14	Airlock in heat exchanger.
15	Too much resistance in the flue system, or flue system has been blocked.
16	Flue system seal damaged causing re-circulation of flue gases.
17	Heat exchanger blocked (insufficient circulation).
18	Ignition electrode defective (porcelain cracked) or incorrect distance to burner control.
19	Moisture in the fan or the fan connections.
20	Fan control plug connected incorrectly.
21	Fan power plug connected incorrectly.
22	Flue gas circulation from behind the heat exchanger.
23	System under very high demand or leak in flow pipework.
24	Pump speed setting has been reduced.
25	Water heater parameters incorrect.
26	Water heater parameters incorrect or ramp delay is too high.
27	Time control set to come on too late.
28	Setpoint is too high
29	Setpoint is too low

TABLE 14.3 POSSIBLE CAUSES

14.10.3 SOLUTIONS

1	Free the pump spindle or replace the pump head.
2	Check cold-water inlet for leaks.
3	Ensure fan is plugged in correctly.
4	Clean the fan blades.
5	Replace the fan
6	Open gas isolating valve.
7	Check gas supply pipes and gas meter are sized correctly.
8	Replace gas supply pipe.
9	Replace fuse F4 checking all 230 V connections e.g. pump, PCB and gas valve
10	See section 12.4.4
11	Check cable for short-circuit, overheating or crush damage. Check spark plug cap for cracks.
12	Check plug fitting gives a positive connection with the gas valve.
13	Remove the bottom section of the condensate drain trap, clean the bottom section and main body.
14	Open the bleed valve located on the left hand side of the heat exchanger. Allow any trapped air to escape.
15	Check the flue system has been sized correctly and is not blocked.
16	Check the condition of all flue joints and seals.
17	Contact Lochinvar Limited for further guidance.
18	Replace if damaged or reposition to be 9mm (\pm 1mm) from the burner.
19	Remove the fan or connections and dry.
20	Check plug is fitted correctly.
21	Check plug is fitted correctly.
22	Check the seal of the heat exchanger on the flue gas casing, and replace as required, fit a new rotary lip seal.
23	Check flow lines and repair as necessary.
24	Turn the pump speed selector to position 3.
25	Contact Lochinvar Limited for further guidance.
26	Contact Lochinvar Limited for further guidance.
27	Alter the time clock settings.
28	Adjust the setpoint to the desired setting.
29	Adjust the setpoint to the desired setting.

TABLE 14.4 SOLUTIONS

15.0 ErP SPECIFICATION DATA SHEET

Water Heater Type:		EF+35/150+	EF+35/150+	EF+35/150+
Manufacturer		Lochinvar Limited		
Load Profile		XL	XL	XXL
Energy Efficiency	%	85.5%	85.5%	86.9%
Daily Electricity Consumption	Qelec	0.169	0.169	0.194
Daily Fuel Consumption	Qfuel	0.079	0.079	0.1
Mixed water V40 @40°C	litre	543	858	∞
Emmissions of Nitrogen Oxides (EN15502)	mg/kwh	41	41	37
Sound Power Level (EN 15036-1:2006)	LWA(db)	61	61	61

16.0 USER INSTRUCTIONS

Once the installation and commissioning is complete, the equipment owner or their representative should be made aware of the operation of the appliance and its safety devices. A practical demonstration should be given describing each functional step. Incorrect use may result in injury and will also invalidate the warranty. The Installation, Commissioning and Maintenance Instructions should be handed over and kept in a safe place for easy reference. It is strongly recommended that the users read and understand the separate User Guide.

NOTES



Lochinvar®
High Efficiency Water Heaters and Boilers

Lochinvar Ltd
7 Lombard Way
The MXL Centre
Banbury
Oxon
OX16 4TJ

Tel: +44 (0) 1295 269981
Fax: +44 (0) 1295 271640
Email: info@lochinvar.ltd.uk

www.lochinvar.ltd.uk

