

CPM

WALL HUNG GAS FIRED CONDENSING BOILERS

Installation, Commissioning and
Maintenance instructions

MODELS
CPM 58
CPM 77
CPM 96
CPM 116
CPM 144
CPM 175

TABLE OF CONTENTS

1	INTRODUCTION	4
1.1	REGULATIONS	4
2	SAFETY GUIDELINES	5
2.1	GENERAL DESCRIPTION OF SAFETY SYMBOLS USED	5
2.2	WHAT TO DO IF YOU SMELL GAS	6
3	TECHNICAL DATA CPM BOILERS	6
3.1	FUNCTIONAL INTRODUCTION	6
3.2	TECHNICAL SPECIFICATIONS DATASHEET.....	7
4	DIMENSIONS	8
4.1	CPM 58-116	8
4.2	CPM 144-175	9
4.3	DIMENSIONS TABLES	10
5	ACCESSORIES AND UNPACKING	10
5.1	ANCILLARY ITEMS	10
5.2	UNPACKING.....	11
6	INSTALLATION OF THE CPM	11
6.1	GENERAL NOTES.....	11
6.2	MOUNTING THE BOILER	12
6.3	BOILER CONNECTIONS.....	13
6.4	CONDENSATE DRAIN CONNECTION.....	13
6.5	BOILER FLOW AND RETURN CONNECTIONS	14
6.6	OPEN VENTED SYSTEM ARRANGEMENT	14
6.7	SEALED SYSTEM ARRANGEMENT.....	14
6.8	EXPANSION VESSEL.....	14
6.9	PRESSURE RELIEF VALVE	14
6.10	BYPASS	14
6.11	PUMP FUNCTIONALITY	15
6.12	FROST PROTECTION.....	15
6.13	INSTALLING A STRAINER AND/OR DIRT SEPARATOR.....	15
6.14	WATER QUALITY.....	16
6.15	SYSTEM SEPARATION USING A PLATE HEAT EXCHANGER	17
6.16	AUTOMATIC AIR VENT.....	18
6.17	DE AERATION PROGRAMME	18
6.18	WATER PRESSURE	18
6.19	HIGHER PRESSURE SYSTEMS (E.G. IN HIGH BUILDINGS).....	18
6.20	CHEMICAL WATER TREATMENT	18
6.21	FLUSH THE SYSTEM	18
6.22	INSTALLATION EXAMPLES.....	19
7	PUMP CHARACTERISTICS	20
7.1	HYDRAULIC GRAPHS.....	20
7.2	PUMPS: MAXIMUM ELECTRICAL POWER.....	23
8	FLUE SYSTEM	24
8.1	GENERAL	24
8.2	FLUE SYSTEM TECHNICAL DETAILS	24
8.3	FLUE TERMINAL LOCATION.....	25
8.4	APPROVED FLUE SYSTEM	26
8.5	INSTALLATION PRECAUTIONS.....	26
8.6	C ₁₃ , C ₃₃ CONCENTRIC FLUE SYSTEMS.....	27
8.7	C ₅₃ TWIN PIPE FLUE SYSTEMS.....	35
8.8	B ₂₃ CONVENTIONAL FLUE INSTALLATIONS	40
8.9	FLUE DISCHARGE	43
8.10	TYPE B ₂₃ (CONVENTIONAL FLUE)	43
8.11	CONVENTIONAL AND TWIN-PIPE FLUE TERMINATION (FLAT AND TILED ROOFS).....	43
8.12	TYPE C ₄₃ U DUCT.....	44
8.13	COMMON FLUE SYSTEMS.....	44
8.14	FLUE TERMINAL GUARDING.....	44
8.15	CONDENSATE DRAIN.....	44

8.16	C ₆₃ CERTIFIED FLUE SYSTEMS	45
9	AIR SUPPLY	45
9.1	COMBUSTION VENTILATION	45
9.2	COOLING VENTILATION	46
9.3	MECHANICAL VENTILATION.....	46
10	ELECTRICAL INSTALLATION	48
10.1	GENERAL	48
10.2	ELECTRICAL CONNECTIONS	48
10.3	CONNECTION DETAILS	48
10.4	ELECTRICAL SCHEMATICS.....	50
10.5	SENSOR VALUES	52
11	USER INTERFACE.....	53
11.1	CONTROL PANEL / DISPLAY UNIT.....	53
11.2	CONTROL PANEL MENU STRUCTURE	54
11.3	DISPLAY DURING OPERATION.....	56
11.4	MONITOR SCREENS	57
11.5	SERVICE FUNCTION	59
11.6	SCHORNSTEIFEGER FUNCTION (GERMANY ONLY)	59
11.7	PROGRAMMING IN STANDBY MODE.....	60
11.8	SETTING THE TIME & DATE	60
11.9	SET POINTS	61
11.10	SETTING THE TIMER PROGRAMS	62
11.11	HEATING PROGRAM.....	62
11.12	HOT WATER PROGRAM.....	64
11.13	PASTEURISATION PROGRAM.....	65
11.14	WEATHER COMPENSATION SETTINGS.....	65
11.15	DISPLAY.....	68
11.16	CHECKING THE OPERATING HISTORY	69
11.17	CHECKING THE FAULT HISTORY	70
11.18	SETTING THE MAINTENANCE PERIOD REMINDER.....	71
11.19	MAINTENANCE SETTINGS	71
11.20	SETTING THE USER LOCK.....	74
11.21	SETTING THE PARAMETERS AT THE CONTROL PANEL.....	75
11.22	FAULT CODES DISPLAY.....	82
11.23	MESSAGES.....	85
12	CONTROL OPTIONS AND SETTINGS.....	86
12.1	GENERAL	86
12.2	HEATING	88
12.3	INDIRECT DHW CYLINDER	91
12.4	CASCADE CONTROL.....	95
13	COMMISSIONING THE BOILER.....	98
13.1	FIRST: FLUSHING THE BOILER WITH WATER	98
13.2	SECOND: FILLING & VENTING THE BOILER AND THE SYSTEM	98
13.3	THIRD: CHECK THE WATER FLOW	98
14	STARTING THE BOILER	100
14.1	GENERAL	100
14.2	FIRING FOR THE FIRST TIME	100
15	ADJUSTING AND SETTING THE BURNER	101
15.1	INTRODUCTION	101
15.2	ADJUSTING: NEW BOILER, OR AFTER MAINTENANCE (CASE A).....	109
15.3	ADJUSTING: GAS VALVE REPLACEMENT OR GAS CONVERSION (CASE B).....	109
15.4	ADJUSTING PROCEDURES	110
16	PUTTING THE BOILER OUT OF OPERATION.....	112
16.1	OUT OF OPERATION: ON/OFF FUNCTION.....	112
16.2	OUT OF OPERATION: POWER OFF.....	112
17	FAULT CODES. BLOCKING CODES.....	113
17.1	FAULT CODES	113
17.2	BLOCKING CODES:	120
17.3	MAINTENANCE ATTENTION FUNCTION.....	123

18	MAINTENANCE	124
18.1	GENERAL	124
18.2	MAINTENANCE REMINDER FUNCTION.....	124
18.3	SERVICE INTERVALS	124
18.4	INSPECTION & MAINTENANCE.....	124
19	USER INSTRUCTIONS	128
20	ERP SPECIFICATION DATASHEET	128
21	INDEX	129

1 INTRODUCTION

This manual has been written for:

- The installer
- System design engineers
- Service engineers
- End user



READ AND UNDERSTAND THE INSTRUCTIONS

Read and fully understand all instructions before attempting to operate maintain or install the unit.

1.1 REGULATIONS

It is the law in the UK that a competent person registered with the HSE approved body and in accordance with the Gas Safety regulations installs all Gas appliances.

Failure to install the appliance correctly could lead to prosecution. It is in your own interest and that of safety to ensure the appliance is installed correctly.

The installation of the water heater must be in accordance with the relevant requirements of the Gas Safety Regulations, Building regulations, I.E.E. regulations and the bylaws of the local water undertaking. The installation should also be in accordance with any requirements of the local gas distributor and local authority. In addition, the installation should follow the relevant guidance offered in the following documents. It is not practical to list all relevant information but emphasis is placed on the following documents, as failure to comply with the guidance given will almost certainly result in an unsatisfactory installation:

Regulation	Description
BS EN 1858: 2008 + A1: 2011	Chimneys, Components. Concrete flue blocks.
BS 5440-1: 2008	Flueing and ventilation for gas appliances of rated input not exceeding 70 kW net (1st, 2nd and 3rd family gases). Specification for installation of gas appliances to chimneys and for maintenance of chimneys.
BS 5440-2: 2009	Installation and maintenance of flues and ventilation for gas appliances of rated input not exceeding 70 kW net (1st, 2nd and 3rd family gases). Specification for installation and maintenance of ventilation for gas appliances.
BS 6644: 2011	Specification for Installation of gas-fired hot water boilers of rated inputs between 70 kW (net) and 1.8 MW (net) (2nd and 3rd family gases).
BS 6700: 2006 +A1: 2009	Design, installation, testing and maintenance of services supplying water for domestic use within buildings and their curtilages.
BS 6880: 1988 Parts 1, 2 and 3	Code of practice for low temperature hot water systems of output greater than 45 kW.
BS 7074: 1989 Parts 1 and 2	Application, selection and installation of expansion vessels and ancillary equipment for sealed systems.
BS 7671: 2008 + A3: 2015	Requirements for electrical installations, I.E.E. wiring regulations seventeenth edition.
BS 7671: Amendment 2: August 2013	
BS EN 12828:2012+A1:2014	Heating systems in buildings. Design for water-based heating systems.
CP 342 (Part 2 1974):	Code of practice for centralised hot water supply-buildings other than dwellings.
IGEM/UP/1 - Edition 2:	Installation pipework on industrial and commercial premises.
IGEM/UP/2: - Edition 3:	Gas installation pipework, boosters and compressors on industrial and commercial premises.
IGEM/UP/4 - Edition 4:	Commissioning of gas-fired plant on industrial and commercial premises.
IGEM/UP/10 - Edition 4:	Installation of flued gas appliances in industrial and commercial premises.

Gas Safety (Installation and Use) Regulations 1998

CIBSE: Guides

Part A Environmental Design

Part G Public health engineering

H.S.E. guidance

INDG 436 Safe management of industrial steam & hot water boilers

SAFED BG01 Guidance on safe operation of boilers

Third edition of the 1956 Clean Air Act Memorandum on Chimney Heights

2 SAFETY GUIDELINES

Keep these instructions near the boiler for quick reference.

This equipment must be installed by a competent person, registered with a H.S.E. approved body. All installations must conform to the relevant Gas Safety and Building Regulations. Health & Safety requirements must also be taken into account when installing any equipment. Failure to comply with the above may lead to prosecution

Without written approval of the manufacturer the internals of the boiler may not be changed. When changes are executed without approval, the boiler certification becomes invalid.

Commissioning, maintenance and repair must be done by a skilled installer/engineer, according to all applicable standards and regulations.

2.1 GENERAL DESCRIPTION OF SAFETY SYMBOLS USED



BANNED

A black symbol inside a red circle with a red diagonal indicates an action that should not be performed



WARNING

A black symbol added to a yellow triangle with black edges indicates danger



ACTION REQUIRED

A white symbol inserted in a blue circle indicates an action that must be taken to avoid risk



ELECTRICAL HAZARD

Observe all signs placed next to the pictogram. the symbol indicates components of the unit and actions described in this manual that could create an electrical hazard.



HOT SURFACES

The symbol indicates those components with a high surface temperature that could create a risk.



This symbol shows essential information which is not safety related



Recover or recycle material

2.2 WHAT TO DO IF YOU SMELL GAS



Warning if you smell gas

- No naked flames, no smoking!
- Avoid causing sparks, do not switch on or off electrical equipment or lights
- Open windows and doors
- Shut off the main gas supply
- Warn occupants and leave the building
- After leaving the building alert the local gas supply company
- Do not re-enter the building until it is safe to do so



Lochinvar Limited is not liable for any damage caused by inaccurately following these mounting instructions. Only original parts may be used when carrying out any repair or service work.



This appliance is not intended for use by persons (including children) with reduced physical, sensory or mental capabilities, or lack of experience and knowledge, unless they have been given supervision or instruction concerning use of the appliance by a person responsible for their safety. Children should be supervised to ensure that they do not play with the appliance.

3 TECHNICAL DATA CPM BOILERS

3.1 FUNCTIONAL INTRODUCTION

This equipment is intended for use on Group H Natural Gas (2nd Family) and LPG propane (3rd Family). The information relating to propane firing is to be found in **Section 15**. This equipment MUST NOT use gas other than that for which it has been designed and adjusted.

The CPM boiler range is supplied as standard set for Natural Gas G20.

Gases used must meet the European standard EN 437.

Fuel used should have sulphur rates according to the European standard, a maximum annual peak over a short period of time of 144 mg/m³ and an annual average of 30 mg/m³.

Standard Boiler control includes:

- Cascade control for up to twelve boilers
- Remote operation and heat demand indication from each boiler
- Weather compensation control
- Indirect DHW Cylinder control

Connections for:

- 0-10 VDC remote flow temperature (set point) control
- 0-10 VDC remote burner input control
- Outdoor temperature sensor
- External Indirect DHW Cylinder pump or diverter valve

Cascade control

When using the integrated cascade control, a maximum of twelve boilers can be controlled in a cascade configuration.

0-10 VDC connection available

The boiler flow temperature or power input can be controlled by an external 0-10 VDC signal. When a number of boilers are cascaded, and controlled by the integrated cascade control, the signal should be directed to the master boiler only. If an alternative control is used, more than one boiler may be controlled by a 0-10 VDC signal. A signal of 1,48 Volt will switch on the boiler(s), less than 1,4 Volt will switch off the boiler(s).

Time program

For both central heating and hot water function of the boiler, time programs with three programmable periods per day are available. These time programs are set and activated by entering the desired settings directly at the boiler control panel.

3.2 TECHNICAL SPECIFICATIONS DATASHEET

Model Number		CPM58	CPM77	CPM96	CPM116	CPM144	CPM175
GENERAL DATA							
Product I.D. Number	CE 0063 BP3254						
Classification	I12H3P						
Gas Appliance Type	B23,B23P,C13,C33,C43,C53,C63,C83						
Input (gross) G20	kW	13.9 - 61.8	16.2 - 82.5	19.1 - 102	28.9 - 123	37.8 - 153	50.0 - 184
Input (gross) G31	kW	13.6 - 60.4	15.9 - 80.8	18.7 - 100	28.3 - 121	37.0 - 150	48.9 - 180
Input (gross) G30/G31	kW	13.5 - 60.3	15.8 - 80.2	18.6 - 99.7	34.7 - 120	36.8 - 150	48.8 - 180
Input (net)	kW	12.5 - 55.6	14.6 - 74.3	17.2 - 92.2	26.0 - 111	34.0 - 138	45.0 - 166
Output (50°/30°)	kW	12.9 - 57.4	15.2 - 77.5	18.0 - 96.2	27.2 - 116	35.5 - 144	47.3 - 175
Output (80°/60°)	kW	12.0 - 53.5	14.0 - 71.2	16.5 - 88.4	24.7 - 106	32.6 - 132	43.3 - 160
Seasonal Efficiency	%	95.2	95.2	95.2	95.4	95.1	95.1
Shipping Weight	kg	46	73	78	83	92	101
Weighted Average NO _x @ 0% O ₂	mg/kWh	37	32	31	38	34	24
Emissions NO _x According to EN15502-A1 2015	mg/kWh	37	46	40	45	41	40
GAS DATA – G20							
Nominal gas inlet pressure	mbar	20					
Maximum gas inlet pressure	mbar	25					
Minimum gas inlet pressure	mbar	17.5					
Gas flow rate	m3/hr	1.32 to 5.88	1.54 to 7.86	1.82 to 9.76	2.75 to 11.8	3.6 to 14.6	4.76 to 17.6
Gas inlet connection size	"BSP	¾				1	
GAS DATA – G31							
Nominal gas inlet pressure	mbar	37					
Maximum gas inlet pressure	mbar	45					
Minimum gas inlet pressure	mbar	27					
Gas flow rate	m3/hr	0.51 to 2.27	0.60 to 3.04	0.70 to 3.77	1.06 to 4.54	1.39 to 5.65	1.84 to 6.79
Gas inlet connection size	"BSP	¾				1	
GAS DATA – G30/G31							
Nominal gas inlet pressure	mbar	50					
Maximum gas inlet pressure	mbar	57					
Minimum gas inlet pressure	mbar	43					
Gas flow rate	m3/hr	0.39 to 1.72	0.45 to 2.29	0.53 to 2.85	0.99 to 3.44	1.05 to 4.28	1.4 to 5.15
Gas inlet connection size	"BSP	¾				1	
ELECTRICAL DATA							
Power consumption	W	240	265	270	280	505	520
Power supply	V/Hz	Single phase 230/50					
Protection class		IPX4D					
WATER DATA							
Water content	litres	3.9	5	6.5	8.3	10.4	12.9
Water connections (F & R) Boiler	"BSP	1				1¼	
Water connections (F & R) T Piece	"BSP	1¼				1½	
Max. water pressure (PMS)	bar	4*					
Min. water pressure	bar	1					
Test pressure	bar	9					
Maximum water temperature	°C	90					
*WHEN USING OPTIONAL EXTERNAL WATER PRESSURE SWITCH THIS IS INCREASED TO 6 BAR							

4 DIMENSIONS

4.1 CPM 58-116

TWIN PIPE

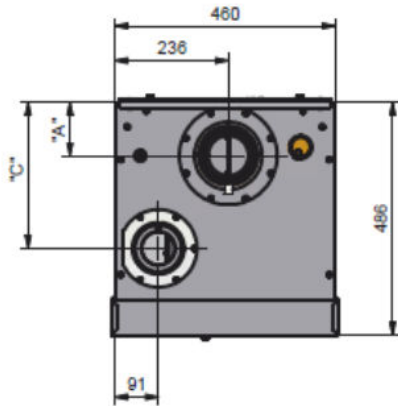

CONCENTRIC

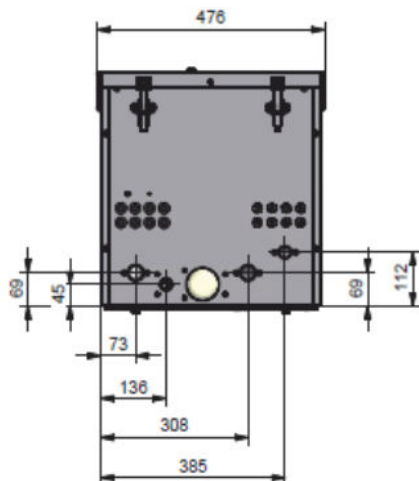
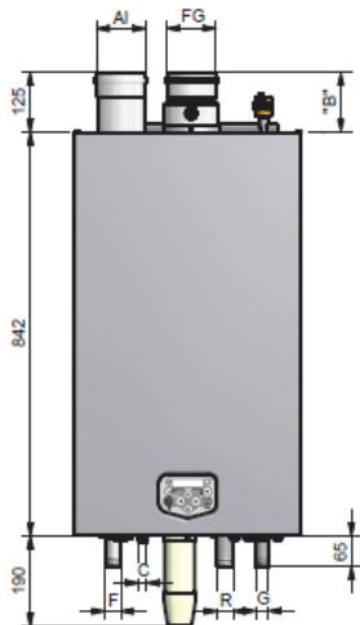
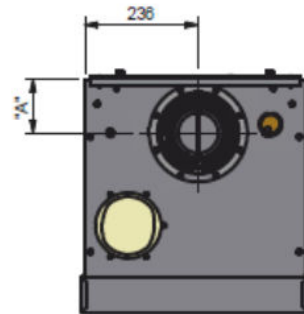

4.2 CPM 144-175

TWIN PIPE

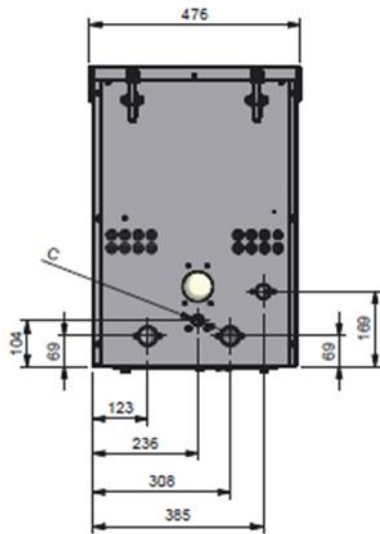
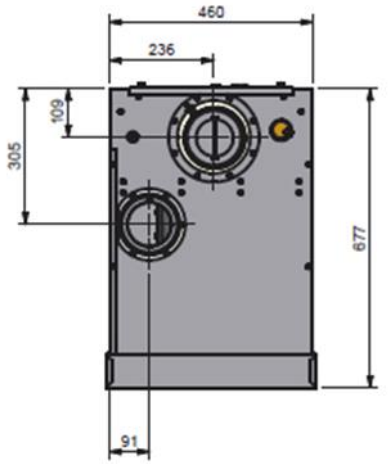

CONCENTRIC

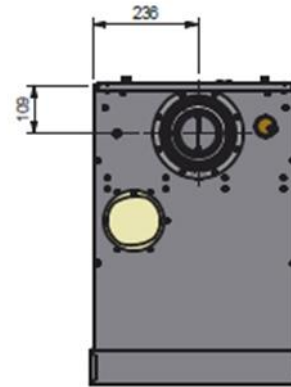

4.3 DIMENSIONS TABLES

To be used in conjunction with drawings at [4.1](#) and [4.2](#)

Connections		Twin pipe					
		CPM 58	CPM 77	CPM 96	CPM 116	CPM 144	CPM 175
FG	flue gas	80-80		100-100		130-130	
AI	air inlet						
size "A"							
size "B"		112				N.A.	
size "C"		135				N.A.	
size "C"		308					
F	flow	R 1¼" (male)				R1½"	
C	condensate	flexible hose Ø25/21 x 750 mm					
R	return	R 1¼" (male)				R1½"	
G	gas	R ¾" (male)				R1"	
Connections		Concentric					
		CPM 58	CPM 77	CPM 96	CPM 116	CPM 144	CPM 175
FG	flue gas	80/125		100/150			
AI	air inlet						
size "A"							
size "B"		155	112			N.A.	
size "C"		150	135			N.A.	
size "C"		N.A.					
F	flow	R 1¼" (male)				R1½"	
C	condensate	flexible hose Ø25/21 x 750 mm					
R	return	R 1¼" (male)				R1½"	
G	gas	R ¾" (male)				R1"	

5 ACCESSORIES AND UNPACKING

5.1 ANCILLARY ITEMS

A number of accessories are available for use with the CPM boiler depending on site requirements as below, contact Lochinvar Limited for prices and further information.

Item Description	Item Number
2 Boiler manifold kit for boilers CPM58 to CPM116	Manifold A
2 Boiler manifold kit for boilers CPM144 to CPM175	Manifold B
3 Boiler manifold kit for boilers CPM58 to CPM116	Manifold C
3 Boiler manifold kit for boilers CPM144 to CPM175	Manifold D
4 Boiler manifold kit for boilers CPM58 to CPM116	Manifold E
4 Boiler manifold kit for boilers CPM144 to CPM175	Manifold F
Boiler Plate Heat Exchangers for system separation	Contact Lochinvar
Calorifier Temperature Sensor- 10kOhm@25°C	S04-016-303
Cascade Flow Sensor	E04-016-304
Outside Temperature Sensor-12kOhm@25°C	E04-016-585
Pressurisation Unit Wall Mounted-Single Pump	CHCWM1
Pressurisation Unit Wall Mounted-Twin Pump	CHCWM2
Condensate Neutralisation Kit	KIT2000
Time, Temperature And Zone Controls	Contact Lochinvar
Flue System Components	See section 8

5.2 UNPACKING

The CPM boiler will be supplied with the following documents and accessories:

- One "Mounting Instructions" manual for the installer
- One suspension bracket with locking plate and bolts
- Three spare nuts for mounting the burner plate, two spare fuses for the boiler control and a gas conversion sticker (all in a bag attached to the front of the gas valve)
- Bottom part of the siphon
- Two T-pieces for the flow and return connections of the boiler

After delivery, check the boiler package to see if everything is included and undamaged. Report any missing items or damage immediately to Lochinvar Customer service.

6 INSTALLATION OF THE CPM

6.1 GENERAL NOTES

The minimum clearances shown below must be maintained to enable service access and prevent operational problems:

Side	50mm
Top	350mm
Bottom	250mm

The installation area/room must have the following provisions:

- 230 V - 50 Hz power source socket with earth connection.
- Open connection to a drain system for the condense trap waste connection.
- A suitable solid load bearing wall, which must be level.



The wall used for mounting the boiler must be able to hold the weight of the boiler. If not, a suitable mounting frame is available from Lochinvar Limited. See section 5.1

Other considerations related to the boiler location.

- Ventilation of the boiler room.
- Both the air Inlet and the flue gas Outlet must be connected to the outside wall and/or the outside roof using a suitable flue system. See section 8
- The installation area must be dry and frost-free.
- The boiler has a built-in fan that will generate noise, depending on the total heat demand. The boiler location should minimise any disturbance this might cause. Preferably mount the boiler on a brick wall.
- There must be sufficient lighting available in the boiler room to work safely on the boiler.



When a boiler is positioned at the highest point of the installation, the supply and return pipes must first protrude 0.5 m above the top of the boiler, before these pipes go to the installation side. In other words, the water level must always be 0.5 meter above the top of the boiler and an automatic air vent must be installed in the supply or return pipe. A low-water level protection should also be installed at the installation side.

It is the law in the UK that a competent person registered with the HSE approved body and in accordance with the Gas Safety regulations installs all Gas appliances.

Failure to install the appliance correctly could lead to prosecution. It is in your own interest and that of safety to ensure the appliance is installed correctly.

6.2 MOUNTING THE BOILER

Before mounting and installing the boiler the following connections should be considered:

- Flue gas system, pipe run and termination
- Ventilation if required
- Flow and return pipe connection
- Condensate and pressure relief valve drain
- Power supply
- Gas pipework



All pipework connections to the boiler must be self-supporting to prevent damage to the boiler and boiler connections.

While marking the holes, ensure that the suspension bracket or frame is perpendicular and the boiler does not lean forward. If necessary adjust the position with the adjusting bolts at the lower rear side of the back panel (see drawing). When the adjusting bolts do not give sufficient adjustment, fill the gap behind the bolts to get the boiler in position. The exact boiler position lies between the boiler hanging level and hanging slightly backwards.



The boiler should not lean forward in the mounted position.

Lock the suspension bracket with the security cover before making any other connections to the boiler. This security cover will prevent the boiler from falling off the bracket. Don't use excessive force during the mounting of the boiler connections.

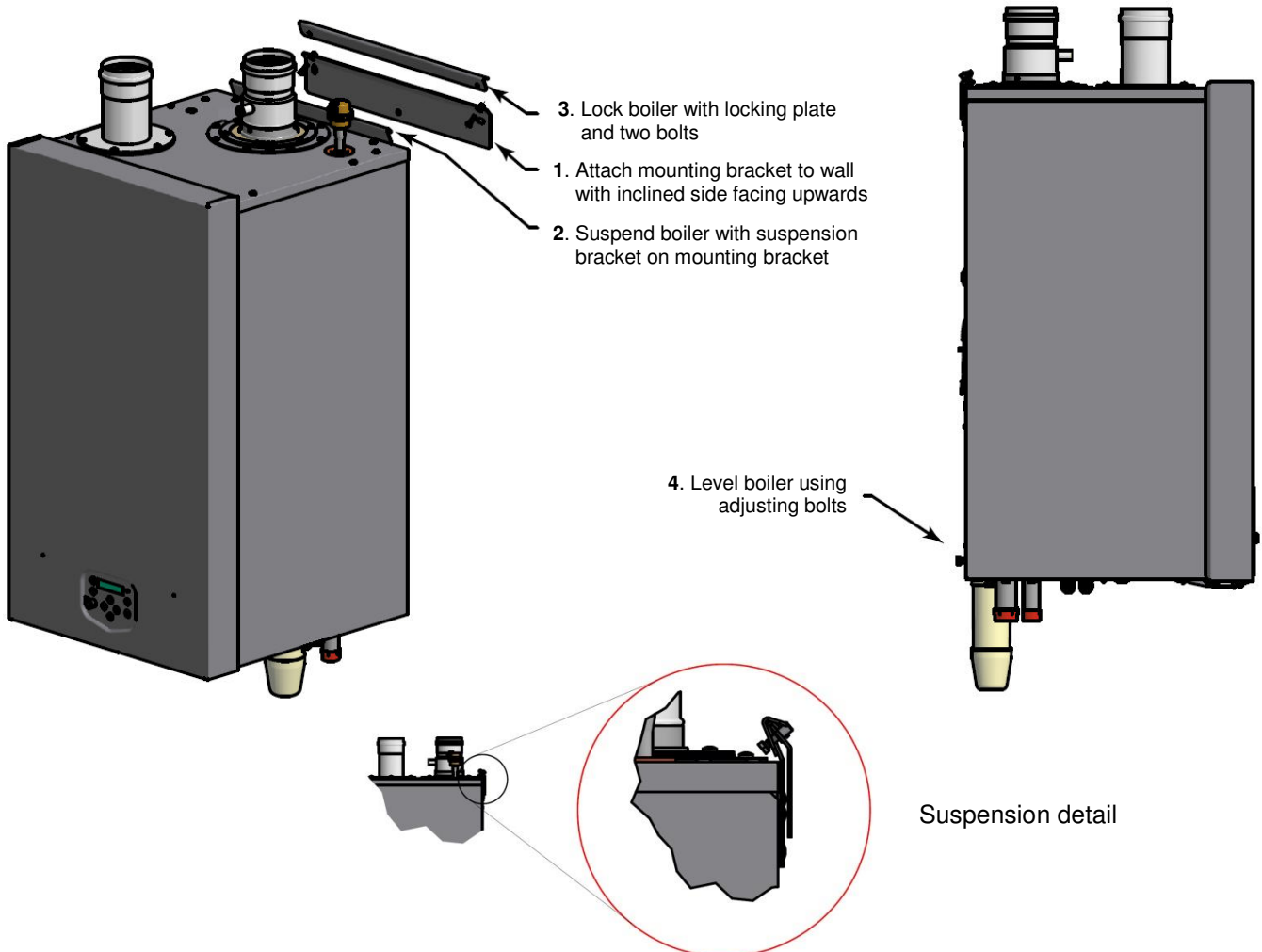

6.3 BOILER CONNECTIONS

FRONT VIEW

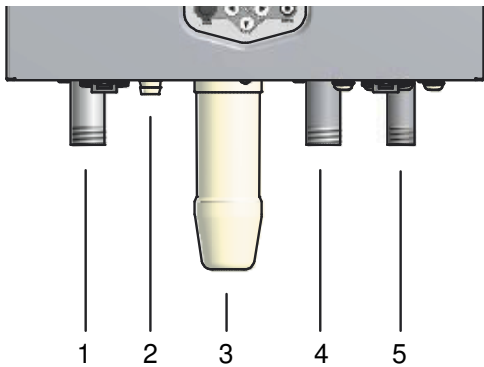

- 1 – Flow CH
- 2 – Condensate drain
- 3 – Siphon cleaning point
- 4 – Return CH
- 5 – Gas

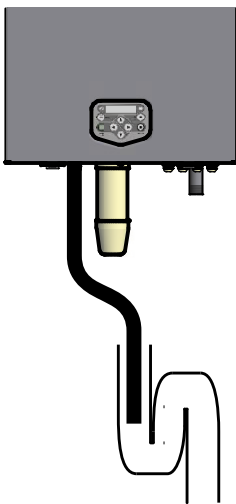

Open connection to the sewer.

6.4 CONDENSATE DRAIN CONNECTION

The condensate drain is placed at the centre and at the bottom of the boiler and has a 3/4 inch hose discharge. This should be connected to an appropriate condensate drain, sloping continuously away from the boiler at an angle of at least 3° (50mm per metre).

Use only plastic parts with the condensate drain.

Blockage of this drain might damage the boiler. The drain connection is correct when the condensate can be seen flowing away, e.g. using a funnel. Any damage that might occur, when the drain is not installed correctly, is not covered by the warranty of the boiler.

There should be an open connection of the condensate hose into the sewage system. A possible vacuum in the sewage system must never give the opportunity to suck on the boiler's condensate drain hose.

The Water Resources Act requires that trade effluent is discharged to municipal sewers between pH 6.5 and 10.0. If it is determined that these levels cannot be achieved, an in-line condensate neutralisation kit is available as an ancillary option from Lochinvar Limited. This unit is capable of neutralising 4000 litres of condensate to a pH of 7.0 before releasing it to a drain.



When mounting the bottom part of the siphon, before commissioning the boiler and/or after maintenance, the siphon must ALWAYS be FILLED COMPLETELY with water.

This is a safety measure: the water in the siphon keeps the flue gases from leaking out of the heat exchanger via the condensate drain.

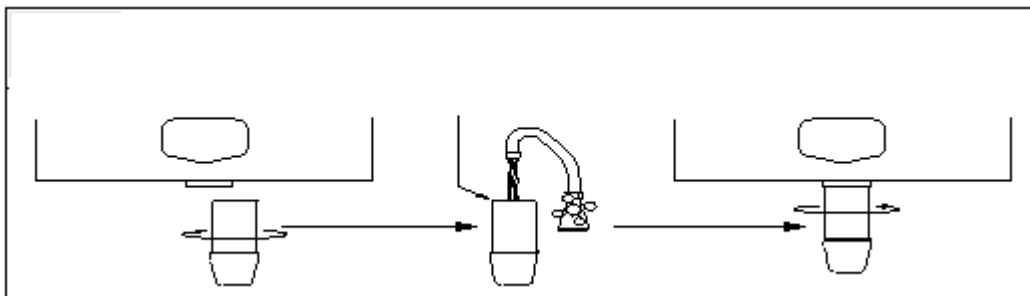

6.5 BOILER FLOW AND RETURN CONNECTIONS

The boiler is supplied with two loose T piece connections; these should be fitted to the boiler before any other connection. One is for installation of a suitable pressure relief valve (not supplied) the second is for a suitable boiler expansion vessel (5litre not supplied) as required under BS6644. A kit is available from Lochinvar.

Boiler Model	BS6644 kit item number
CPM58-CPM77	LM900032A
CPM96-COM175	LM900033A

6.6 OPEN VENTED SYSTEM ARRANGEMENT

The Lochinvar CPM can be used in an open vented arrangement provided that a vent pipe in accordance with CP 342 or BS6644 as appropriate is fitted. The minimum static head requirement for an open vented system is 1.0 bar.

6.7 SEALED SYSTEM ARRANGEMENT

If a sealed system arrangement is required, a suitable pressurisation unit is available from Lochinvar Limited on request. Sealed systems should incorporate a safety valve with a lift pressure no greater than the maximum pressure rating of any component in the heating system. The maximum working pressure of the boiler is 6.0bar. A suitably sized expansion vessel should also be fitted to the system in accordance with BS4814.

When using a Pressure make up system precautions should be taken to monitor water usage within the heating system (fresh water =fresh oxygen into the system), such as a water meter on the inlet to the pressure make up unit. Regular monitoring should take place to monitor water usage and steps taken to repair any leaks. Damage to the boiler heat exchanger due to fresh water intake will not be covered under the heat exchanger warranty. In hard water areas this is especially important.

The appliance is fitted with a water pressure sensor and requires a nominal system pressure of 1.0 bar. The burner control will block the boiler from operating if the system pressure drops below a pressure of 0.8 bar; once the system pressure rises above 1.0 bar, the block will be lifted. The maximum system pressure with the standard pressure sensor is 4.0 bar however, a pressure switch may be used if the static head exceeds this. For further details on the connection of a water pressure switch, please refer to Section 6.18

6.8 EXPANSION VESSEL

A suitable system expansion vessel must be installed within the system.

The following information is based on a static head of 3.5bar. If a different cold fill pressure is to be used, please consult BS4814.

$$V V = S V * e$$

0.45

Where:

V V = Vessel Volume

S V = System Volume

e = Coefficient of Expansion(See Table below)

Stored Temp. C	30	35	40	45	50	55	58
e	0.005	0.006	0.008	0.010	0.012	0.015	0.017
Stored Temp. C	65	70	75	77	82	85	90
e	0.020	0.023	0.026	0.030	0.031	0.033	0.037

6.9 PRESSURE RELIEF VALVE

The boiler has no internal pressure relief valve. This should be installed close to the boiler in the flow pipe of the heating system. When multiple boilers are to be installed, each boiler should have its own pressure relief valve. See section 6.3 for advice on a suitable installation point. Service valves must be installed to each boiler, so the boiler can be isolated from the heating system, when required. Make sure that the pressure relief valve is mounted between the boiler and the service valves.

The specifications and size of the relief valve should be determined by the installer and must comply with BS6644.

6.10 BYPASS



The boiler has no internal bypass. A suitable bypass should be installed if the system is fitted with thermostatic radiator or zone valves that will prevent a suitable flow around the boilers when all zones have shut. If fitting with a Low Velocity header the bypass will not be required.

6.11 PUMP FUNCTIONALITY

Controlling the pump:

The pump speed is controlled by a PWM signal provided by the burner controller at a value causing a Delta T across the heat exchanger of 20K at the whole burner modulation range.

When the boiler modulates down or up, the pump speed decreases or increases, keeping delta T at 20K until it reaches the end of its modulation range.

Delta T monitoring:

The delta T monitoring parameters are active. A faulty pump, burner controller or a high resistance in the hydraulic system will cause a high Delta T and will therefore be detected by the burner controller. The display shows “dT Block” or “FlowReturn dTfault”.

6.12 FROST PROTECTION

The boiler has a built-in frost protection; the internal pump is activated when the boiler return (water) temperature drops below 5°C (programmable). When the boiler return temperature drops below 3°C (programmable), the burner is also ignited. The pump and/or burner will shut down as soon as the return temperature has reached 10°C (programmable). These temperatures are measured by the RETURN sensor of the boiler. This frost protection function will not fire up the boiler in case of a “general blocking” of the burner demand or power supply failure.



This “Frost Protection” function only protects the boiler and not for the whole heating system. Frost Protection function is a programmable setting; as such any boiler damaged by frost is not covered under warranty.

6.13 INSTALLING A STRAINER AND/OR DIRT SEPARATOR

Due to the high-efficiency, low water content design of the heat exchanger, it is necessary to install a method of removing dirt from the system. A dirt separator or strainer should be installed in the system return line and checked on a weekly basis to ensure an adequate flow is maintained whilst ensuring that the heat exchanger does not get blocked. Where a strainer is used, it is recommended that isolation valves are installed either side of the strainer and a bleed point is installed to aid in the routine maintenance.



Blockage of the heat exchanger due to the ingress of debris from the system is not a manufacturing defect and is not covered by the warranty.



When a CPM boiler is installed on a heating system containing iron, oxygen in the water can react to form the mineral magnetite. Due to the highly magnetic nature of magnetite, the mineral can create flow restrictions in the heat exchanger, which may result in premature failure. When installing a CPM boiler the system must be fully flushed to remove all existing traces of magnetite and an air separator should be fitted to prevent any further development. The air separator should be installed in the hottest part of the heating system, i.e. on the flow out of the low velocity header, and in accordance with the item manufacturer’s instructions. See typical layout in table in Section 6.13.1.

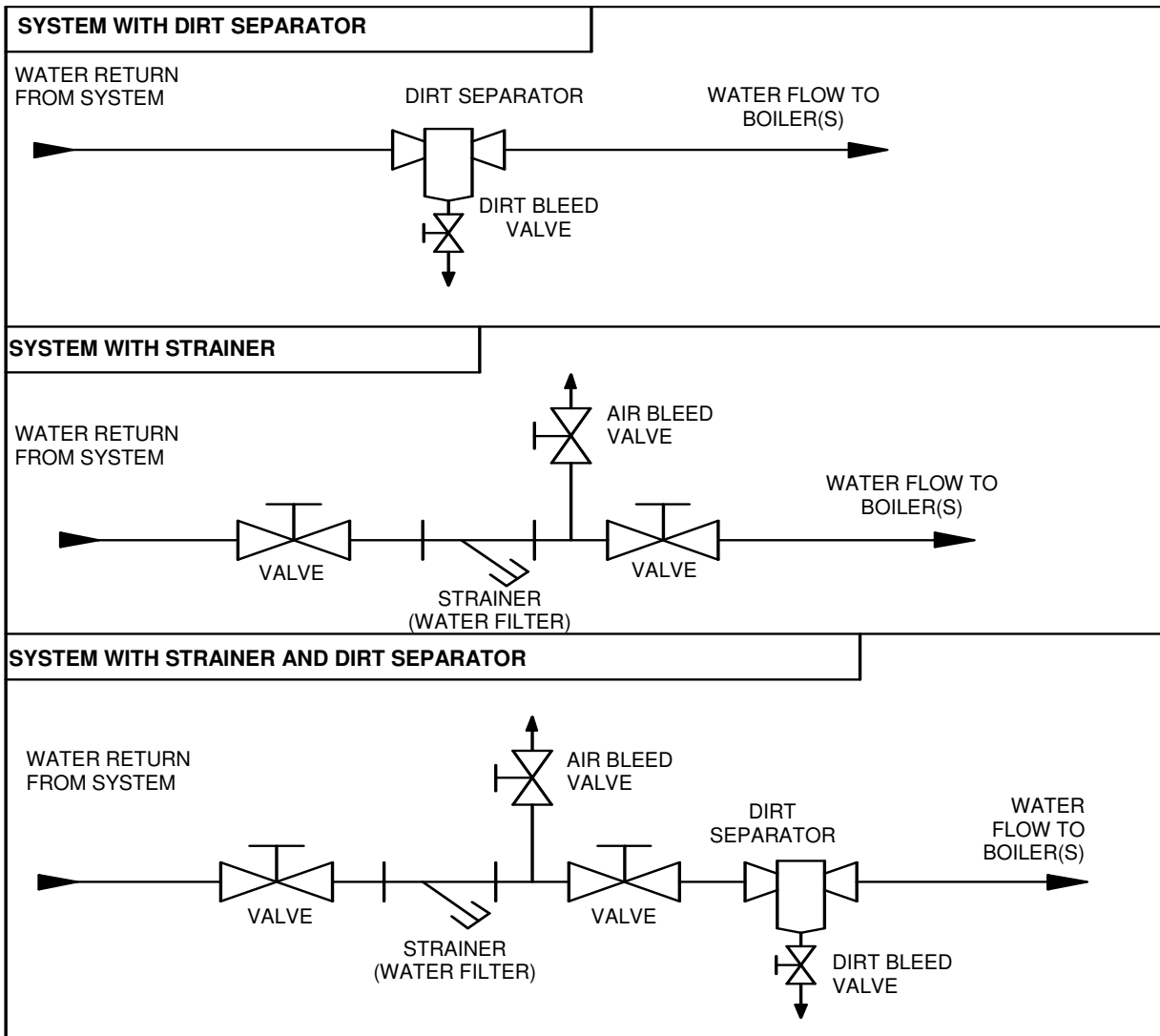

6.13.1 Hydraulic protection of the heat exchanger

6.14 WATER QUALITY

In hard water areas, scale formation can occur in hot water systems. The situation can intensify where higher temperatures or demands exist.

- The pH value of the water must be between 7.5 and 9.5.
- Water hardness must be between 50 ppm CaCO₃ and 144 ppm CaCO₃
- The Aluminium content of the TDS (Total Dissolved Solids) should not exceed 8.5 ppm.



If the above requirements cannot be satisfied, a water treatment specialist must be consulted. Failure of the heat exchanger due to deposit build up is not considered a manufacturing defect and will not be covered under warranty.

6.15 SYSTEM SEPARATION USING A PLATE HEAT EXCHANGER

If the integrity of the heating system cannot be guaranteed or if the system is highly contaminated then the primary (Boiler) loop and secondary (System) loop should be hydraulically separated to prevent damage to the boilers using a plate heat exchanger. These are available as an ancillary extra from Lochinvar Limited.



Damage occurring to the boiler heat exchanger due to system contamination or air will not be covered under the boiler warranty.

When installing a CPM with a plate separator the boiler will be the highest point in the Primary system and as such, the installation must comply with the drawing 6.15.1 and points 1-6

1. The plate separator must be sized specifically for each project (Lochinvar can supply this plate)
2. The plate separator must be installed as per the ICM instructions and installed Vertically only
- 3.



The supply and return pipes must first protrude 0.5 m above the top of the boiler, before these pipes go to the Plate Heat Exchanger. In other words, the water level must always be 0.5 meter above the top of the boiler.

4. A suitable Auto Air valve must be fitted to the highest point
5. A suitable auto fill system should be installed to prevent nuisance call out whilst the oxygen within the water is depleted (Lochinvar can supply a suitable solution)
- 6.



A low-water level protection must be installed to protect the boilers in case of a system leak.

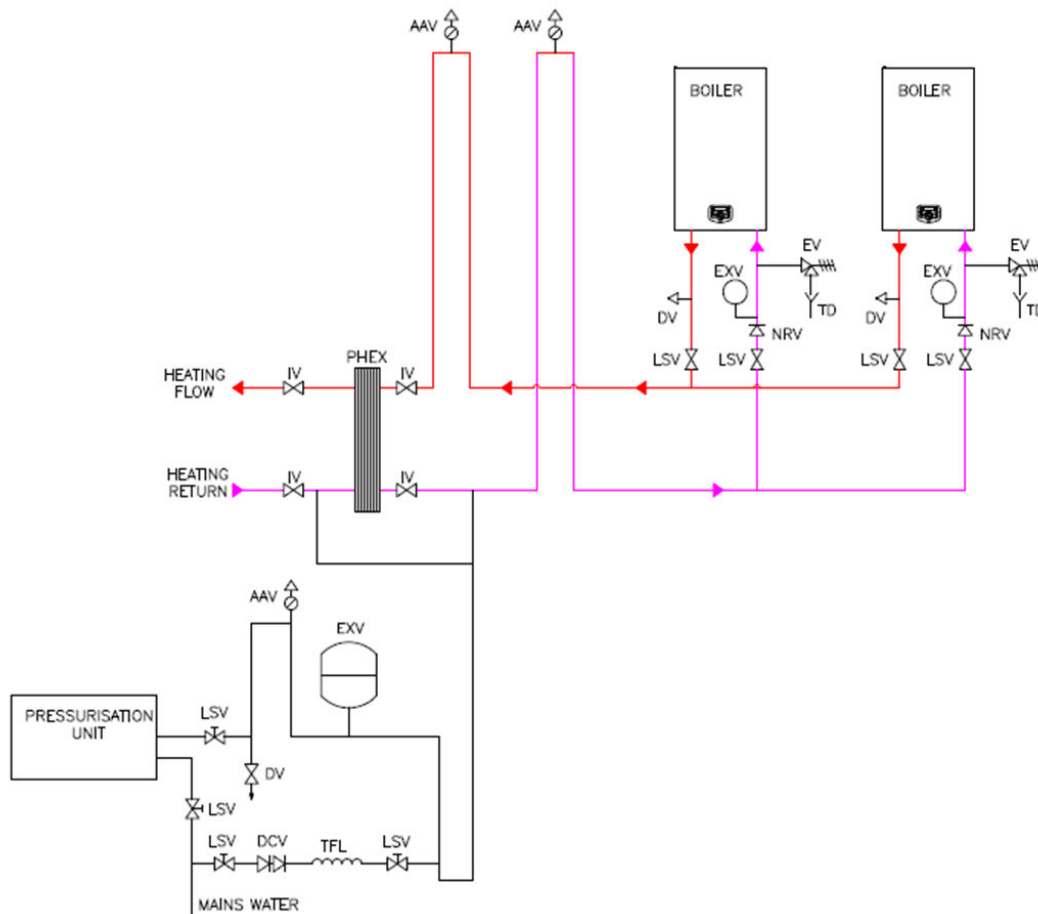

6.15.1 CPM Installation using a plate separator

6.16 AUTOMATIC AIR VENT

An automatic air vent is mounted on the boiler to remove the air from the water circuit.



This automatic air vent is only used for bleeding the air from the heat exchanger of the boiler. One or more external automatic air vent(s) and/or air separators must always be mounted in the heating system to remove air from the heating system.

6.17 DE AERATION PROGRAMME

When the unit is fired for the first time the unit starts a de-aeration program. One cycle means 5 seconds pump running and 5 seconds pump off. A complete de-aeration program consists of three cycles. The de-aeration program can be interrupted or stopped by briefly pressing the service button.

6.18 WATER PRESSURE

The CPM Boiler is fitted with a water pressure sensor, this will shut down the boiler should the system pressure drop below 0.8 bar. The maximum system pressure should not exceed 4bar. Normal working pressure should be between 1.5 and 2bar.

The pressure sensor will stop the boiler from firing when the water pressure drops below 0.8bar, and start the boiler firing again when the water pressure reaches above the 1.0bar. These values can be changed in the boiler control settings.

6.19 HIGHER PRESSURE SYSTEMS (E.G. IN HIGH BUILDINGS)

If pressures higher than 4.0 bar occur in the heating system, the best solution is to separate the system from the boiler by means of a plate heat exchanger. Boiler pressure can still be under 4.0bar and the boiler control remains as described above.

An alternative option is to replace the pressure sensor with a 6.0bar pressure switch available as an ancillary option; the boiler control needs to be adjusted.

6.20 CHEMICAL WATER TREATMENT

If the requirements in section 6.14 cannot be satisfied, a water treatment specialist must be consulted. Details of companies that provide such a service can be obtained from Lochinvar Limited.

6.21 FLUSH THE SYSTEM

The system should be thoroughly flushed in accordance with CIBSE Commissioning Codes B & W and BSRIA AG1/2001.1: Pre-commission cleaning of pipework systems.

Check the system for leaks and repair as necessary. If the system is configured in a sealed arrangement, check the expansion vessel cushion pressure and pressurisation unit settings.

6.22 INSTALLATION EXAMPLES

6.22.1 Example of a STANDARD single boiler heating circuit with low loss header

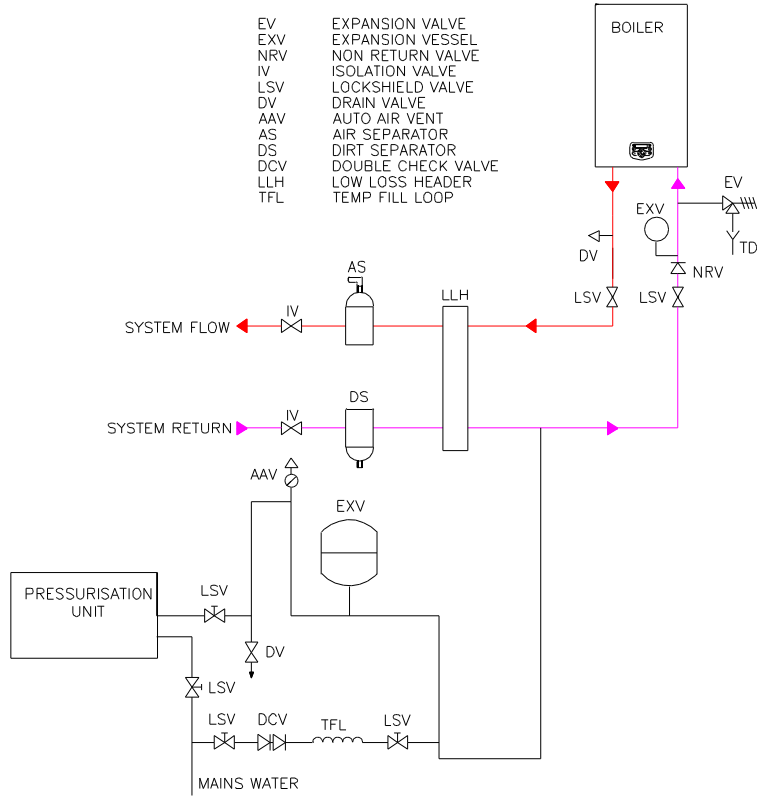

6.22.2 Example of a multiple boiler heating circuit with low loss header

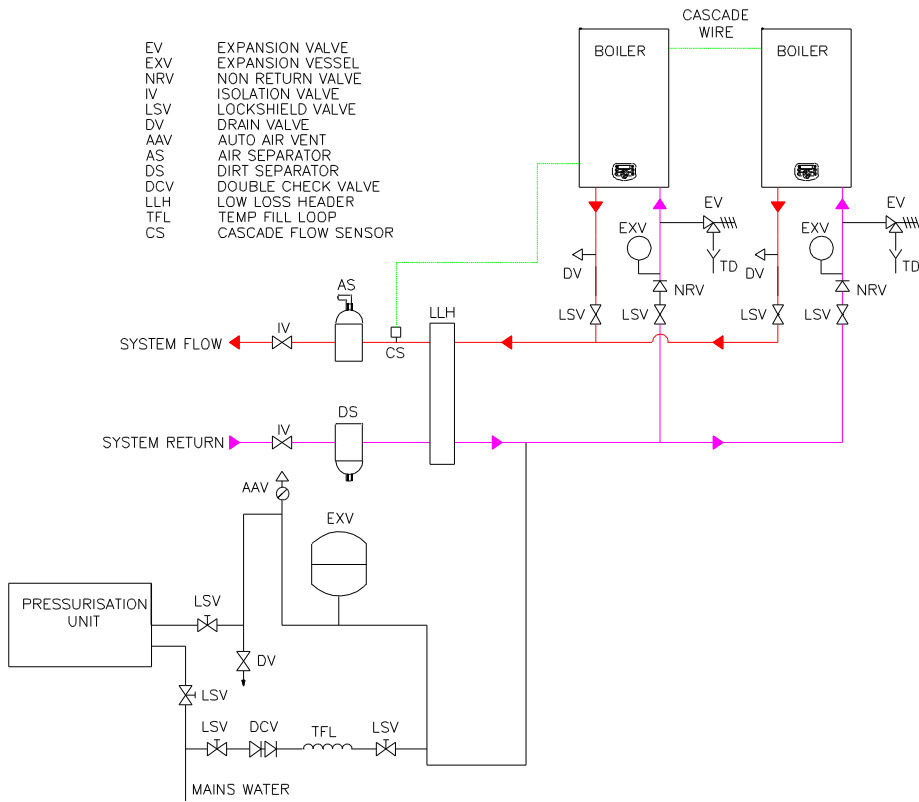

7 PUMP CHARACTERISTICS

7.1 HYDRAULIC GRAPHS

Boiler and pump graph CPM 58 UPML 25-105PWM:

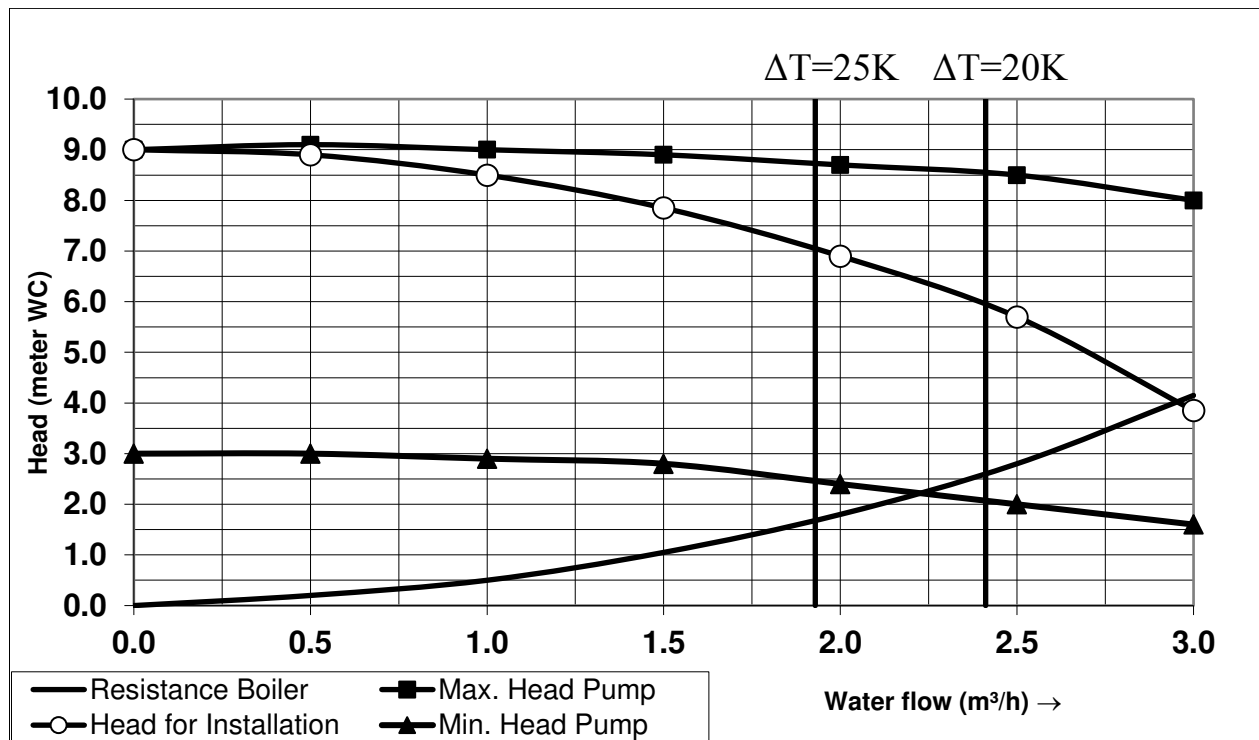

Boiler and pump graph CPM 77 UPML 25-105PWM:

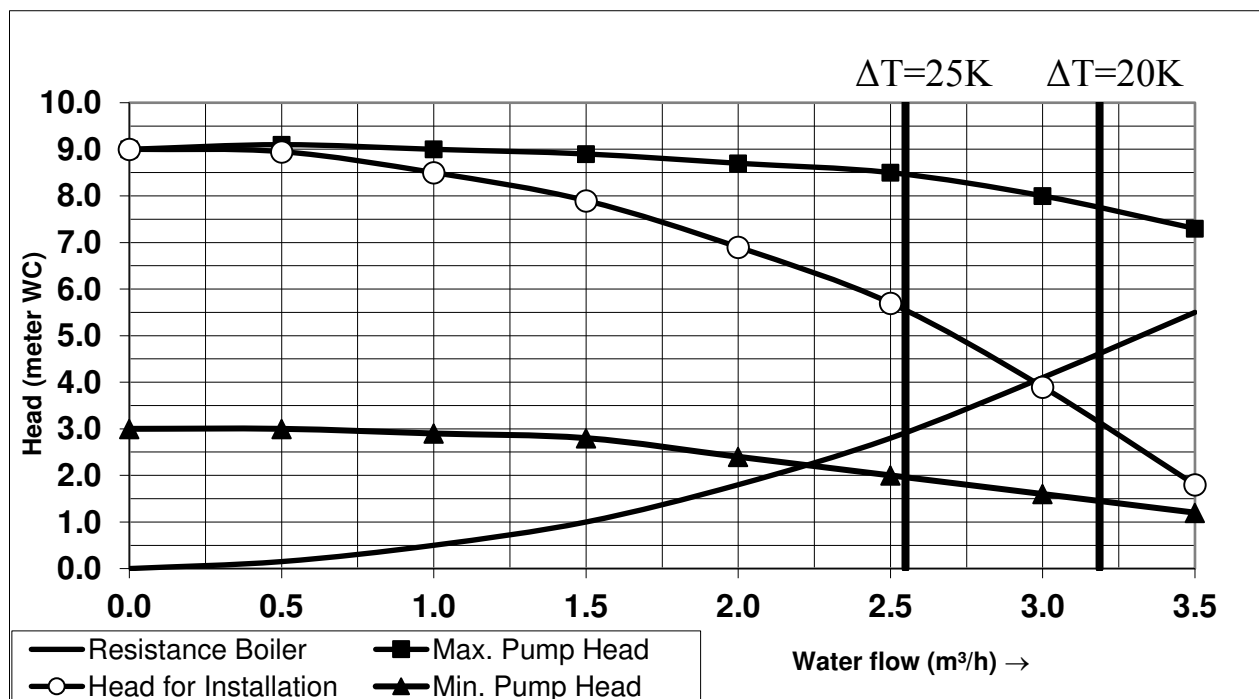

Boiler and pump graph CPM 96. UPML 25-105PWM:

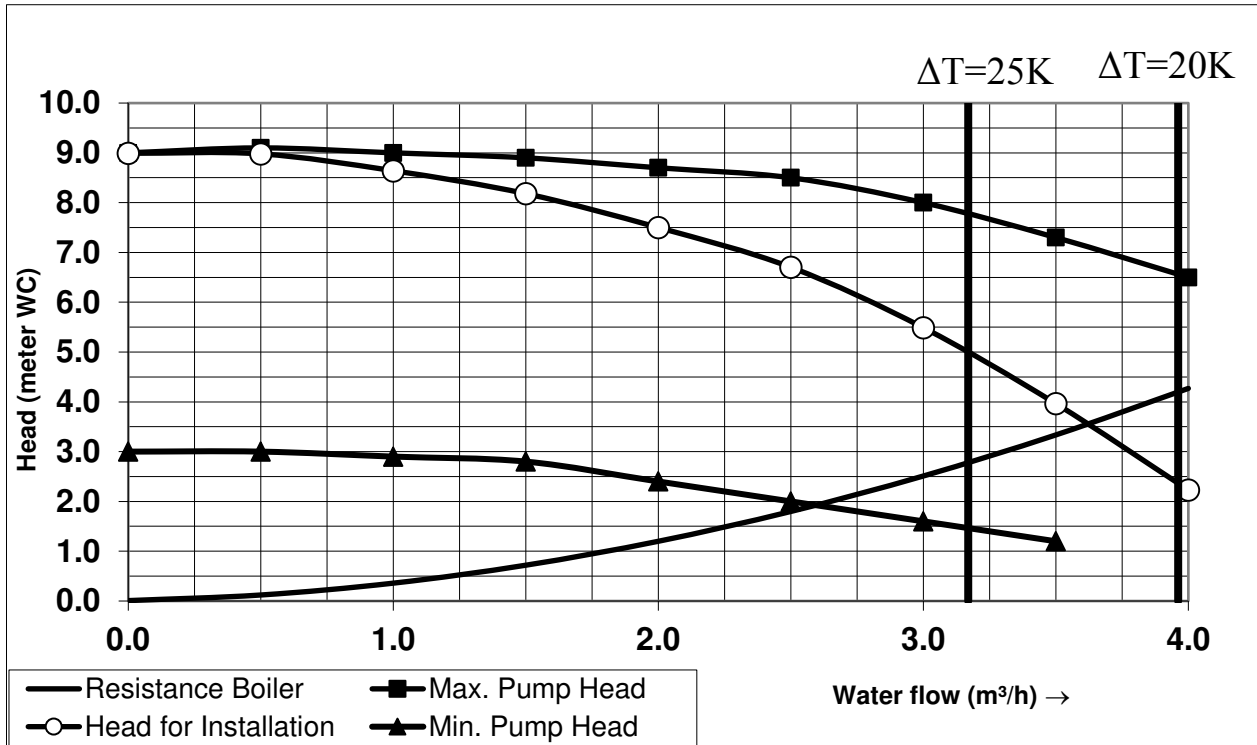

Boiler and pump graph CPM 116. UPML25-105 PWM:

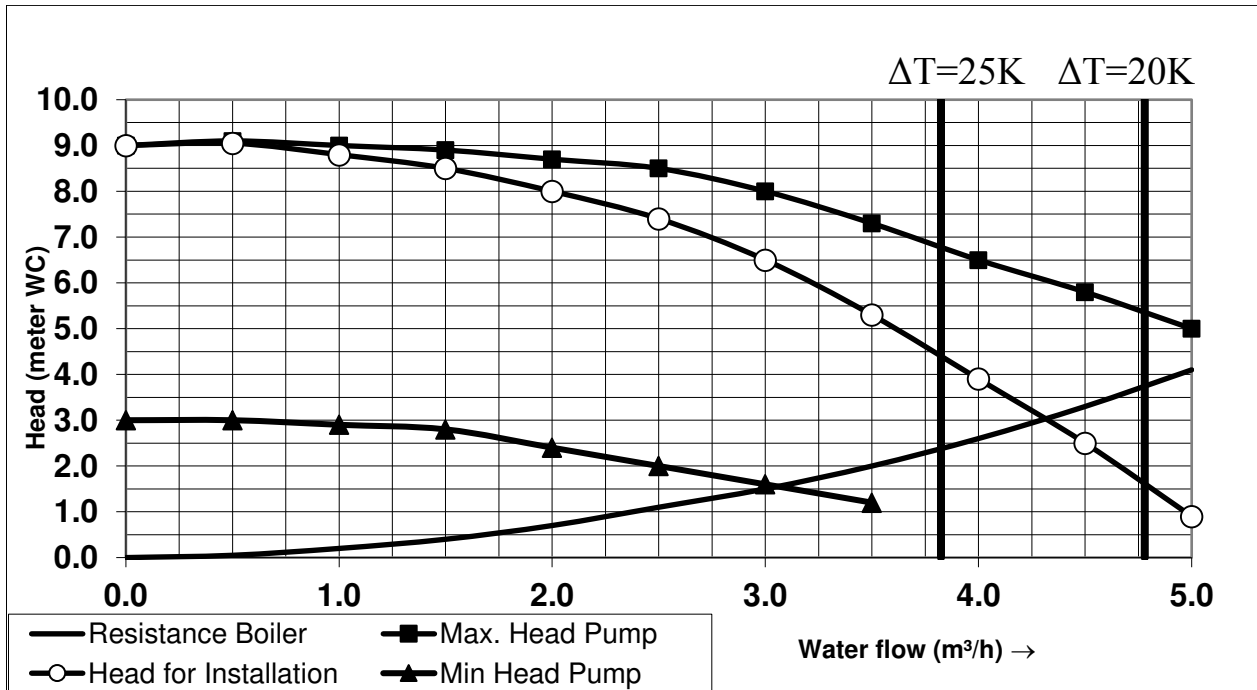

Boiler and pump graph CPM 144. Wilo Stratos Para 30/1-12 PWM:

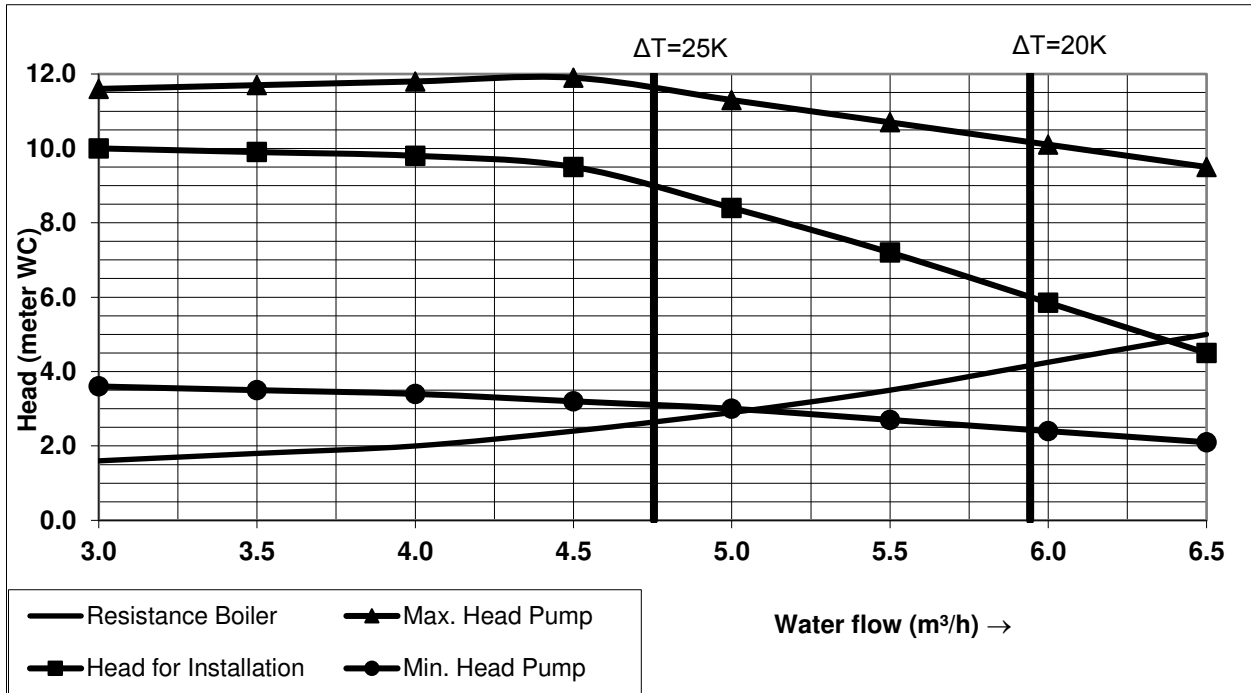

Boiler and pump graph CPM 175. Wilo Stratos Para 30/1-12 PWM:

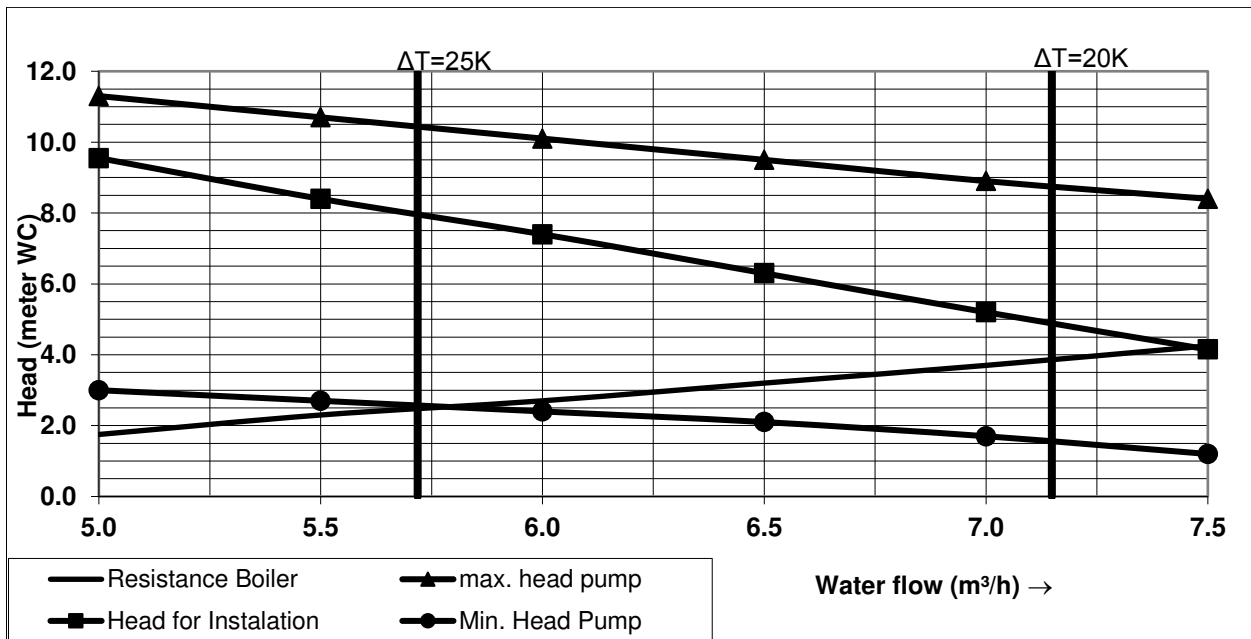

The CPM boiler is equipped with a high efficiency pump; the hydraulic graphs show the minimum and maximum head for the pump. This is the range in which the pump will modulate. The pump speed is controlled by a PWM signal provided by the burner controller and will maintain a Delta T across the heat exchanger of 20°C across the whole burner modulation range.

7.2 PUMPS: MAXIMUM ELECTRICAL POWER

General

- The maximum switch current of the PCB is 5 Amp
- Any pump being controlled by the boiler PCB must not exceed 2 Amp.

Pump P1 - boiler pump.

This modulating pump is part of the appliance. The speed and power consumption depends on the Delta T across the heat exchanger and is controlled by the burner controller.

Pump P2 - Indirect DHW Cylinder pump.

Pump P2 is a DHW pump and is used when P4AA = 1, meaning the appliance is supplying an indirect DHW Cylinder. Pumps P1 and P2 are connected to one fuse of 5 A, so their total nominal current may not exceed 5 A. To limit the inrush current, the switching sequence has been modified so pump P2 always switches 96 ms later than pump P1. The maximum nominal current of pump P2 must also be 2 Amp again due to the inrush current.

3 way valve.

The combined nominal current of pump P1 and the 3 way valve must be smaller than 5 Amp
So, the inrush current of the 3 way valve must be lower than 3 Amp

Pump P3 - system pump.

The nominal current of pump P3 must be equal to or lower than 2 Amp

Warning (EC pumps):

The pump should be connected to an external power supply.

Control connections of an EC pump can be established in several ways, set by parameter P5BN.

See Section 12.1.7 on page 87.



When using electronic commutating (EC) pump, the relays 1, 2 or 3 may not be used for the power connection, because of the starting current of these pumps.

8 FLUE SYSTEM

8.1 GENERAL

The boiler has a positive pressure flue system. The available combined pressure drop for the inlet and outlet system is **200 Pa for the complete boiler range.**



Install the horizontal flue components with an angle of 3° back in the direction of the boiler (roughly equal to five centimetres for every linear meter). Failure to install the flue correctly will result in a build-up of condensate within the flue pipework that will cause early component failure.



When using a wall terminal, there is the possible risk of ice building-up on surrounding parts/structures, because the condensate will freeze. This risk should be taken into account during the design phase of the heating installation.



CPM Boilers will produce large condensate clouds especially during cold weather, consideration must be taken as to whether this will cause a nuisance to neighbouring properties and if so alternative flue arrangements used.



The CPM boiler can operate with very low flue temperatures; as such the flue system used must be suitable for use with condensing appliances made from either Polypropylene or stainless steel and have a temperature class of T120.



Aluminium flue pipe must not be used on this appliance as it may lead to premature failure of the heat exchanger and will invalidate the warranty.



Before installation of any flue system read the installation manual carefully for both the appliance and flue system to be used. Information on the flue system Supplied by Lochinvar can be found within this manual.

8.2 FLUE SYSTEM TECHNICAL DETAILS

Model Number		CPM58	CPM77	CPM96	CPM116	CPM144	CPM175
FLUE DATA TYPE B₂₃							
Nominal flue diameter	mm	80		100		130	
Maximum flue gas temp	°C	120					
Flue gas temperature	°C	85-95					
Flue draught requirements	mbar	-0.03 to -0.1					
Available pressure for the flue system	Pa	200					
Maximum flue gas volume	g/s	5.59 to 28.9	6.52 to 38.6	7.69 to 47.9	11.6 to 57.7	15.2 to 71.7	20.1 to 86.2
FLUE DATA TYPE C₁₃ & C₃₃							
Nominal flue diameter	mm	80/125		100/150			
Maximum flue gas temp	°C	120					
FLUE DATA TYPE C₄₃ & C₅₃							
Nominal flue diameter	mm	80		100		130	
Maximum flue gas temp	°C	120					

8.3 FLUE TERMINAL LOCATION

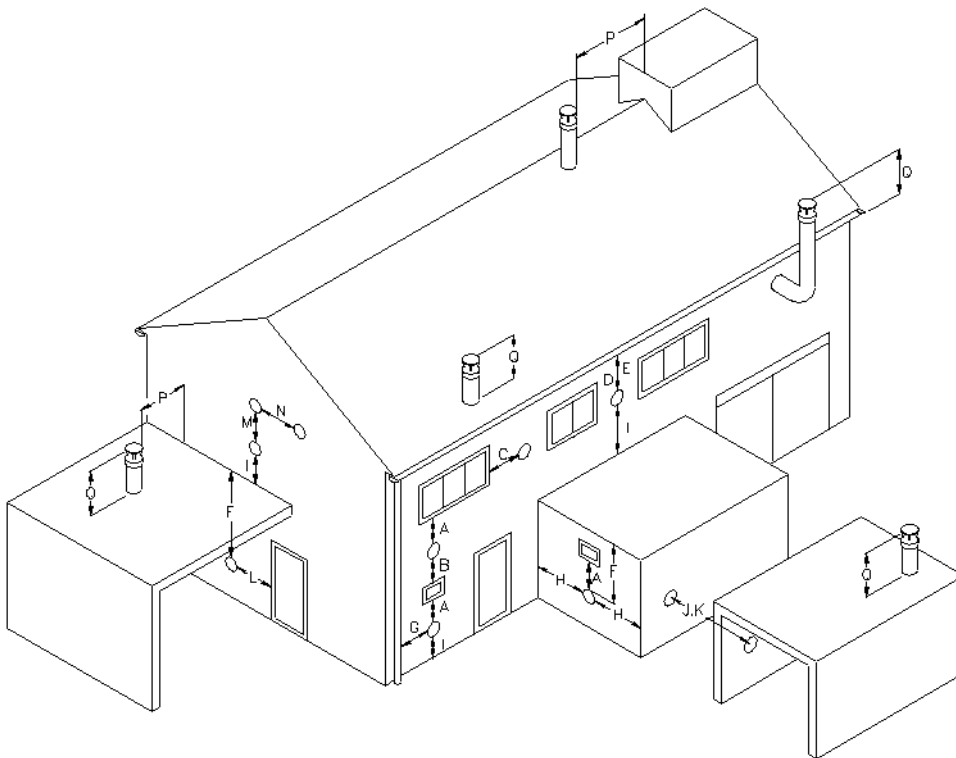

8.3.1 Flue Terminal Positions

Location	Description	CPM 58	CPM 77 – CPM 175
A	Directly below an opening, air brick, opening windows etc.	300	2000
B	Above an opening, air brick, opening windows etc.	300	960
C	Horizontally to an opening, air brick, opening windows etc.	300	960
D	Below a gutter or sanitary pipework	75	75
E	Below the eaves	200	200
F	Below a balcony or car port roof	200	200
G	From a vertical drain or soil pipe	144	144
H	From an internal or external corner	300	300
I	Above ground, roof or balcony level	300	300*
J	From a surface facing the terminal	577	960
K	From a terminal facing the terminal	1160	2000
L	From an opening in the car port (e.g. door, window) into the dwelling	1160	1160
M	Vertically from a terminal on the same wall	1440	1440
N	Horizontally from a terminal on the same wall	300	577
P	From a vertical structure on the roof	300	300
Q	Above intersection with the roof	300	300

8.3.2 Flue Terminal Minimum Distances

*Any termination of a room sealed appliance shall be in such a position as will not cause a hazard to the health of persons who may be nearby or a nuisance to other persons beyond the curtilage. The height to the centreline of the terminal shall not be less than 2m from occupied external areas.

Detailed recommendations for the flue system are given in **BS5440-1** for equipment of rated input not exceeding 70kW net, **BS6644** for equipment above 70kW net and **IGE/UP/10** for equipment of rated input above 54kW net. The following notes are intended to give general guidance only.

8.4 APPROVED FLUE SYSTEM



The approved flue system is not suitable for use external to the building. If external routes cannot be avoided, a flue system manufacturer must be consulted to supply a suitable alternative.



CPM 58 – CPM 116 boilers are supplied for connection to a concentric flue system. If twin pipe or conventional flue is used, a conversion kit will be required.



CPM 144 & CPM 175 boilers are supplied for connection to a twin pipe or conventional flue system. If concentric flue is to be used, a conversion kit will be required.

When used as a Type C (Balanced Flued) appliance, the approved, purpose designed adaptive flue system from Lochinvar should be used. Concentric and twin-pipe options are available.

When used as a Type B (Conventional Flued) appliance, a suitable flue system constructed of Stainless Steel or Polypropylene with a temperature rating in excess of 120°C should be used. Internal flue items are available from Lochinvar. For further details of available components see CPM Flue assembly and ancillaries' document available at www.lochinvar.ltd.uk



Aluminium flue pipe must not be used on this appliance as it may lead to premature failure of the heat exchanger and will invalidate the warranty.

8.5 INSTALLATION PRECAUTIONS

- The approved flue system is rated to 120°C max.
- The heater must not be operated unless the complete flue system is installed. This includes the boiler connections, twin-pipe conversion kit (if required) flue pipes, air ducts (if required) and terminals. If discharging at low level, a suitable flue guard must be installed.
- Due to the condensing nature of the boiler, long external runs should be avoided to prevent the condensate freezing within the flue system.
- During assembly of the flue system, precaution should be taken to ensure that the internal sealing ring is seated correctly.
- Due to the close tolerances in the flue system, it may be necessary to use a twisting action to fit the joints together. No lubrication other than water should be used.

8.6 C₁₃, C₃₃ CONCENTRIC FLUE SYSTEMS

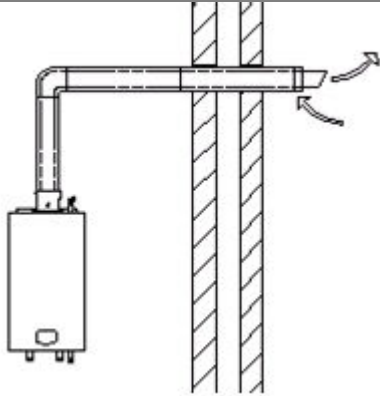

C₁₃

FLUE SYSTEM SPECIFICATION

- MANUFACTURER MUELINK & GROL
- TEMPERATURE CLASS T120
- FLUE GAS MATERIAL PP

EACH HORIZONTAL CONCENTRIC FLUE ASSEMBLY IS SUPPLIED WITH THE FOLLOWING ITEMS:

- CONCENTRIC WALL TERMINAL
- WALL PLATES
- 90° BEND

ADDITIONAL FLUE ITEMS ARE AVAILABLE SEE FLUE ASSEMBLY AND ANCILLARIES GUIDE AT WWW.LOCHINVAR.LTD.UK

8.6.1 C₁₃ Horizontal Concentric Flue System Components

Model	Description	Flue Assembly Item number
CPM58	Horizontal Concentric flue kit 80/125mm	CPMH001
CPM77	Horizontal Concentric flue kit 80/125mm	CPMH001
CPM96	Horizontal Concentric flue kit 100/150mm	CPMH003
CPM116	Horizontal Concentric flue kit 100/150mm	CPMH003
CPM144	Horizontal Concentric flue kit 100/150mm	CPMH004
CPM175	Horizontal Concentric flue kit 100/150mm	CPMH004

8.6.2 C₁₃ Horizontal Concentric Flue Assemblies

8.6.3 Horizontal Terminal Installation

When the heater is installed as a Type C₁₃ appliance, the flue system should be installed as follows:

1. Determine the location of the flue terminal, taking into account minimum distances as detailed in **Section 8.3, Section 8.3.1** and the relevant British Standards.
2. Taking care to protect the appliance from debris and dust, drill a hole in the desired location. The diameter of the hole should be no more than 10mm greater than the diameter of the air supply pipe of the terminal.
3. Determine the required length of the terminal and cut as necessary.

NOTE: When determining the required length for the flue terminal, the outer wall plate or rosette should be flush to the wall. See drawing below

NOTE: Once cut; remove all burrs and sharp edges.

4. Insert the terminal into the drilled hole. The terminal section should be installed level or with a fall to outside (Max. 10 mm per metre) to prevent the ingress of water.

NOTE: When inserting the terminal, ensure the air intake section is at the bottom.

5. Fill the void between the terminal and wall with water resistant sealant.
6. Fit the wall plates or rosette using appropriate fixings.
7. Install the remainder of the flue system working progressively away from the boiler supporting the pipes as necessary.

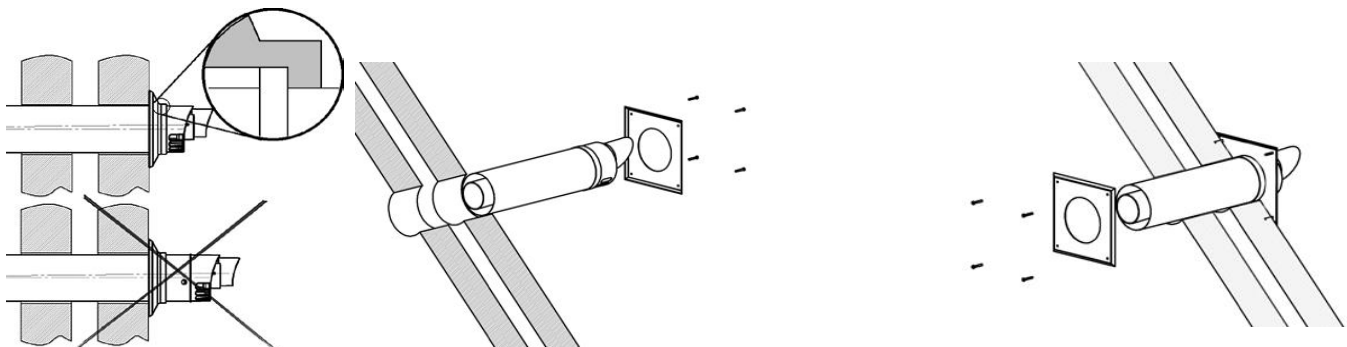

8.6.4 Horizontal Concentric Flue Terminal

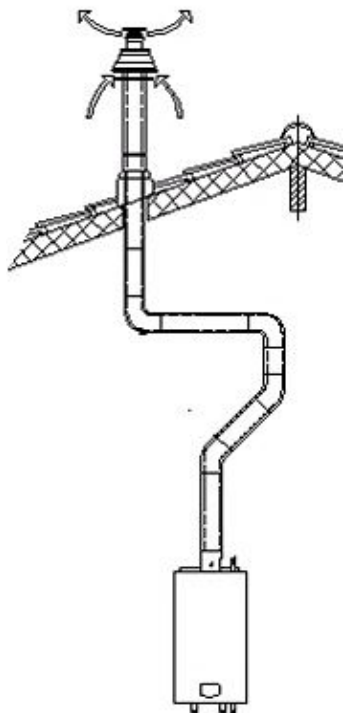

FLUE SYSTEM SPECIFICATION

- MANUFACTURER MUELINK & GROL
- TEMPERATURE CLASS T120
- FLUE GAS MATERIAL PP

EACH VERTICAL CONCENTRIC FLUE ASSEMBLY IS SUPPLIED WITH THE FOLLOWING ITEMS:

- CONCENTRIC VERTICAL TERMINAL Ø80/125MM PP
- CONCENTRIC EXTENSION Ø80/125mm (500mm) PP CUT TO LENGTH

ADDITIONAL FLUE ITEMS ARE AVAILABLE SEE FLUE ASSEMBLY AND ANCILLARIES GUIDE AT WWW.LOCHINVAR.LTD.UK

8.6.5 C₃₃ Vertical Concentric Flue Assembly

Model	Description	Flue Assembly Item number
CPM58	Vertical Concentric flue kit 80/125mm	CPMV001
CPM77	Vertical Concentric flue kit 80/125mm	CPMV001
CPM96	Vertical Concentric flue kit 100/150mm	CPMV003
CPM116	Vertical Concentric flue kit 100/150mm	CPMV003
CPM144	Vertical Concentric flue kit 100/150mm	CPMV004
CPM175	Vertical Concentric flue kit 100/150mm	CPMV004

8.6.6 C₃₃ Vertical Concentric Flue Assemblies

8.6.7 Vertical Terminal Installation

When the heater is installed as a Type C₃₃ appliance, the flue system should be installed as follows:

1. Confirm that the roof flashing is correct for the type of roof through which the terminal is to be installed. (See **Section 8.11**)
2. Determine the desired location for the flue terminal, taking into account minimum distances as detailed in **Section 8.3**, **Section 8.3.1** and the relevant British Standards.
3. Taking care to protect the appliance from debris and dust, drill a hole in the desired location. The diameter of the hole should be no more than 10mm greater than the diameter of the air supply pipe of the terminal.

NOTE: The hole should be drilled from the outside to ensure that no damage is done to the roofing material. Extra care should be taken to ensure that the hole is drilled vertically.

4. Install the roof flashing and secure as appropriate.
5. Carefully insert the roof terminal through the roof flashing and hole in the roof.

NOTE: When inserting the roof terminal do not support or turn the terminal using the cap.

6. Ensure the terminal is vertical using a spirit level.
7. Fit the support bracket around the terminal and secure using appropriate fixings. Do not tighten the support bracket.
8. Install the remainder of the flue system working progressively away from the boiler supporting the pipes as necessary.
9. Once the flue system is fully installed, tighten the clamp to secure the terminal in place.

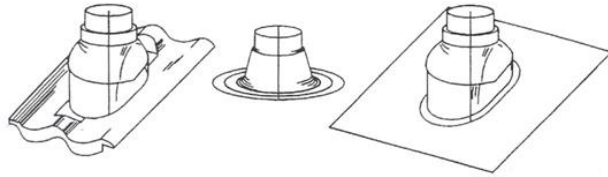

8.6.8 Vertical Terminal Roof Flashings For Synthetic, Flat And Tiled Roofs

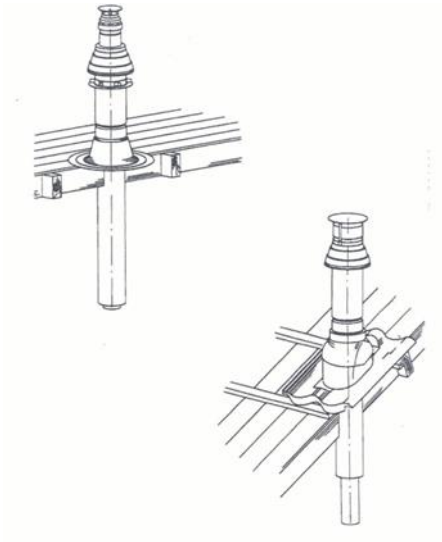

8.6.9 Installing Terminal Through Roof Flashing

8.6.10 General Concentric Flue System Installation Guidelines

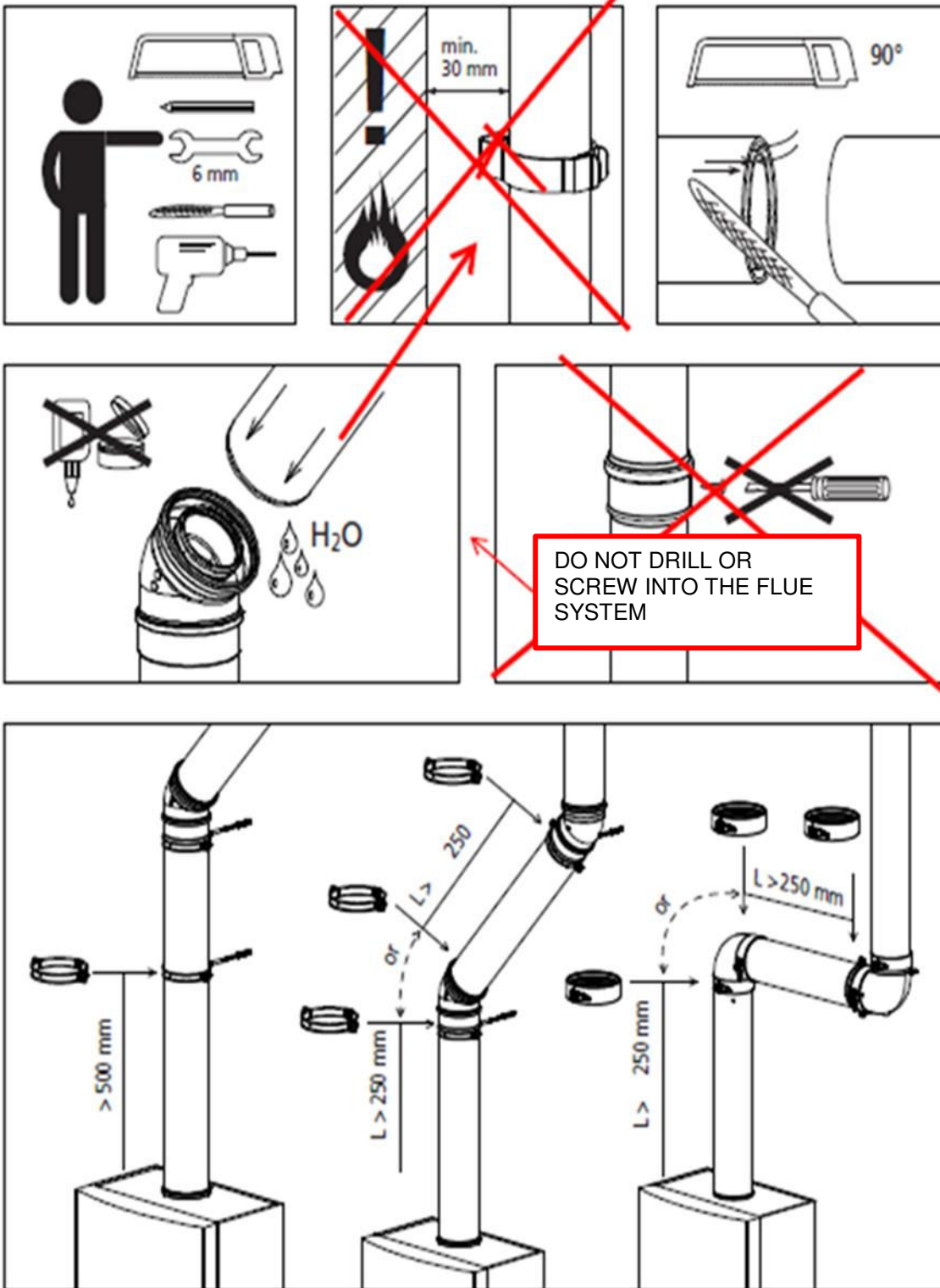

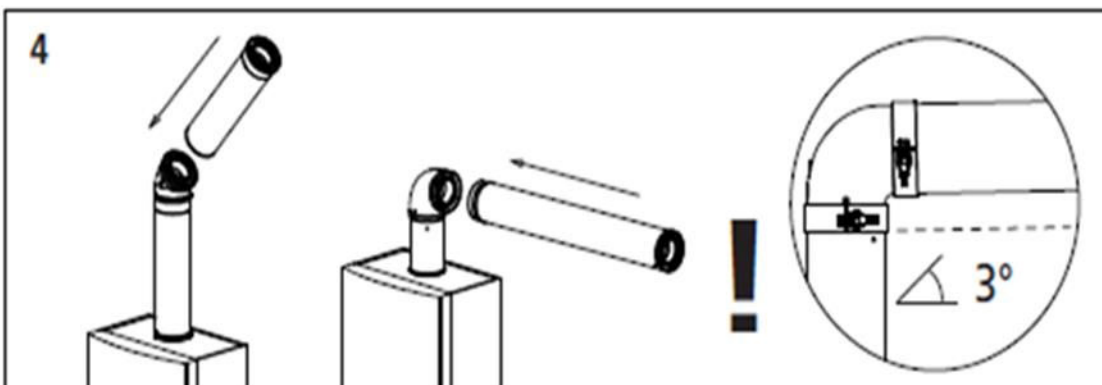
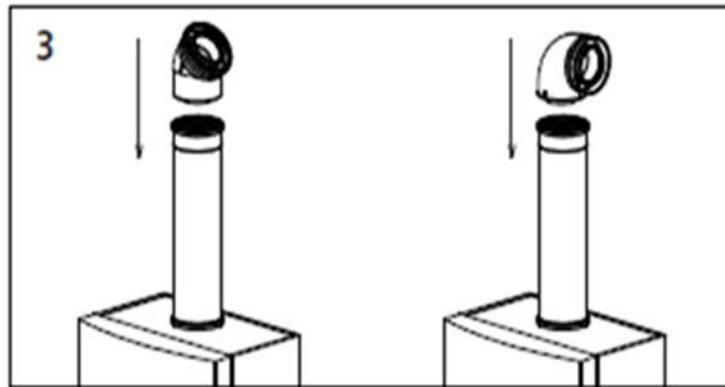
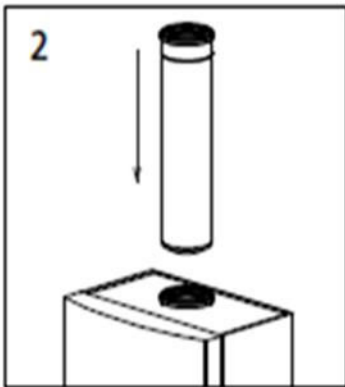
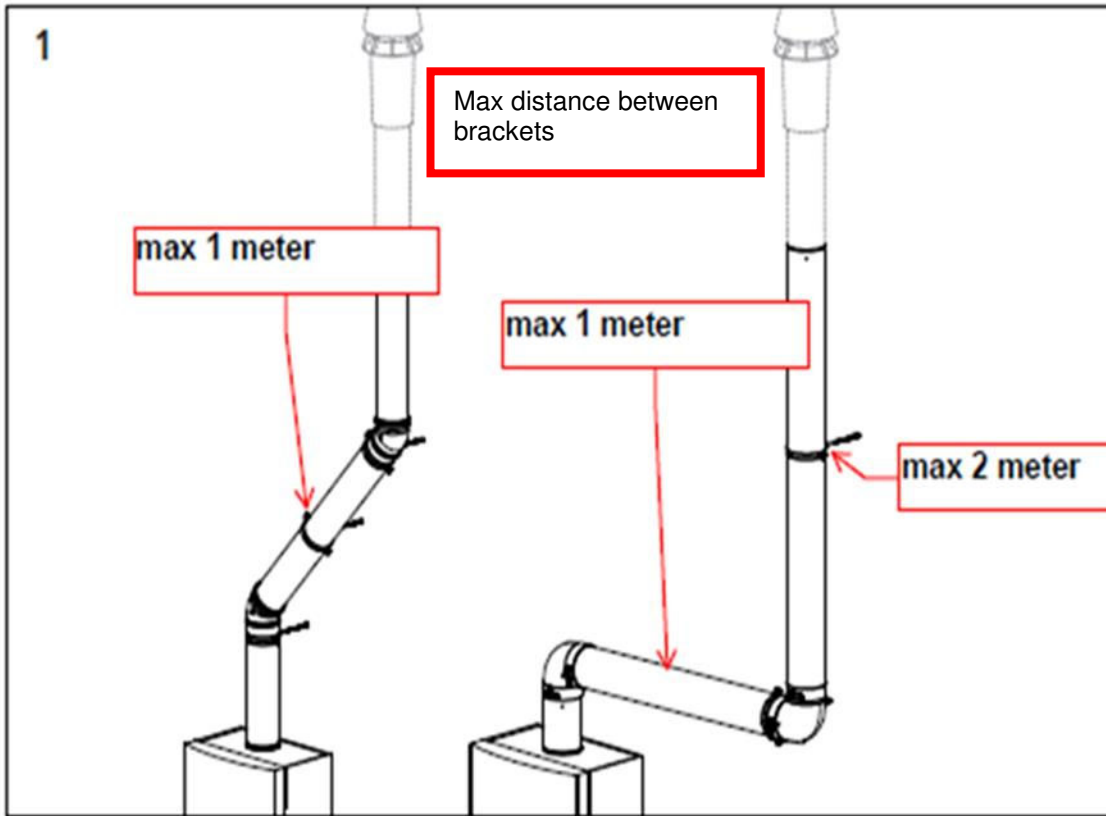

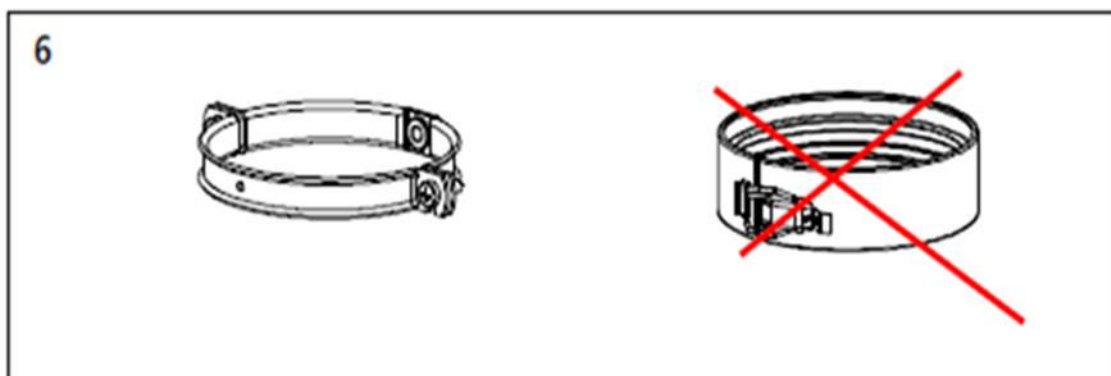
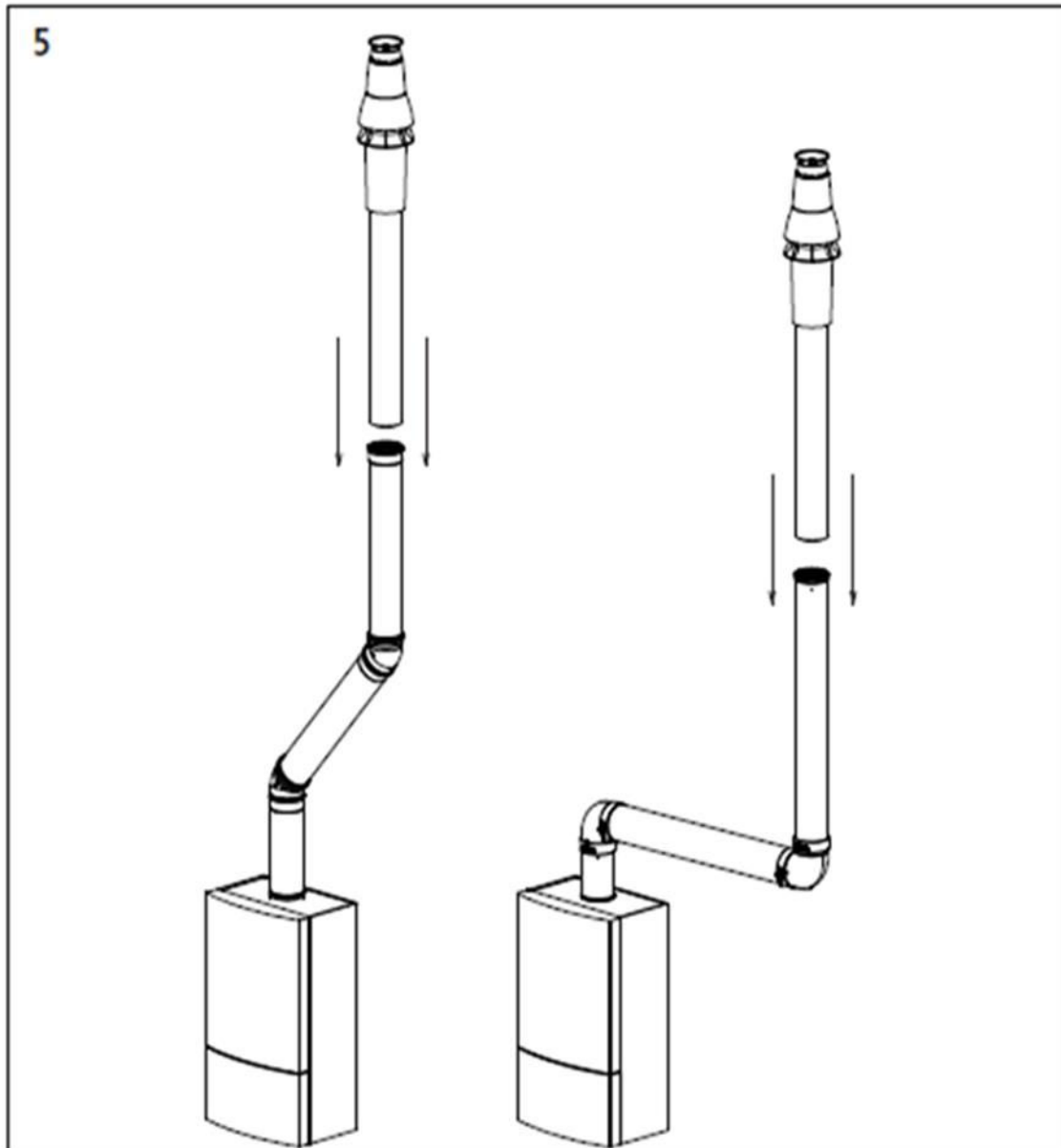

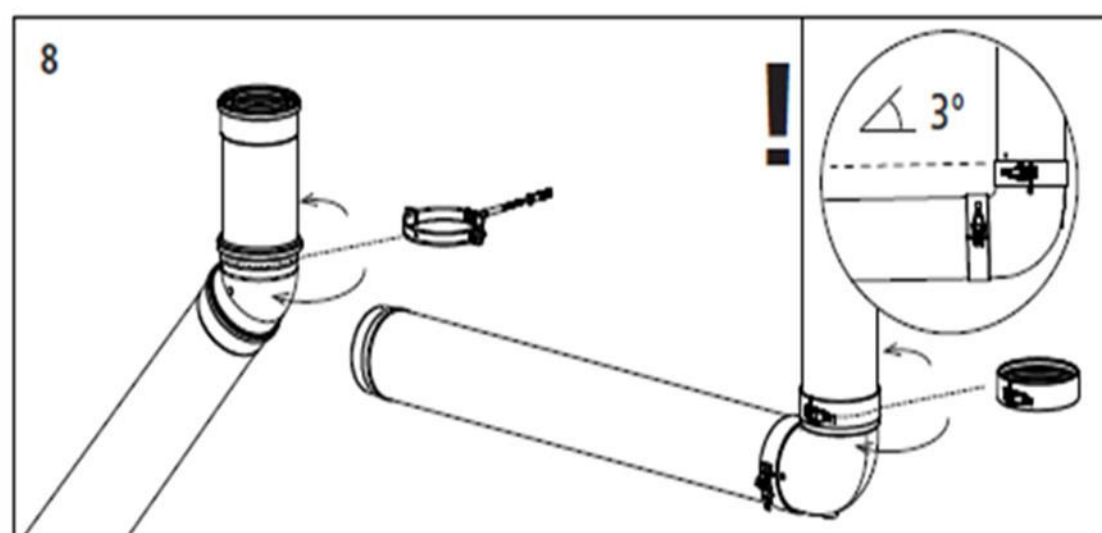
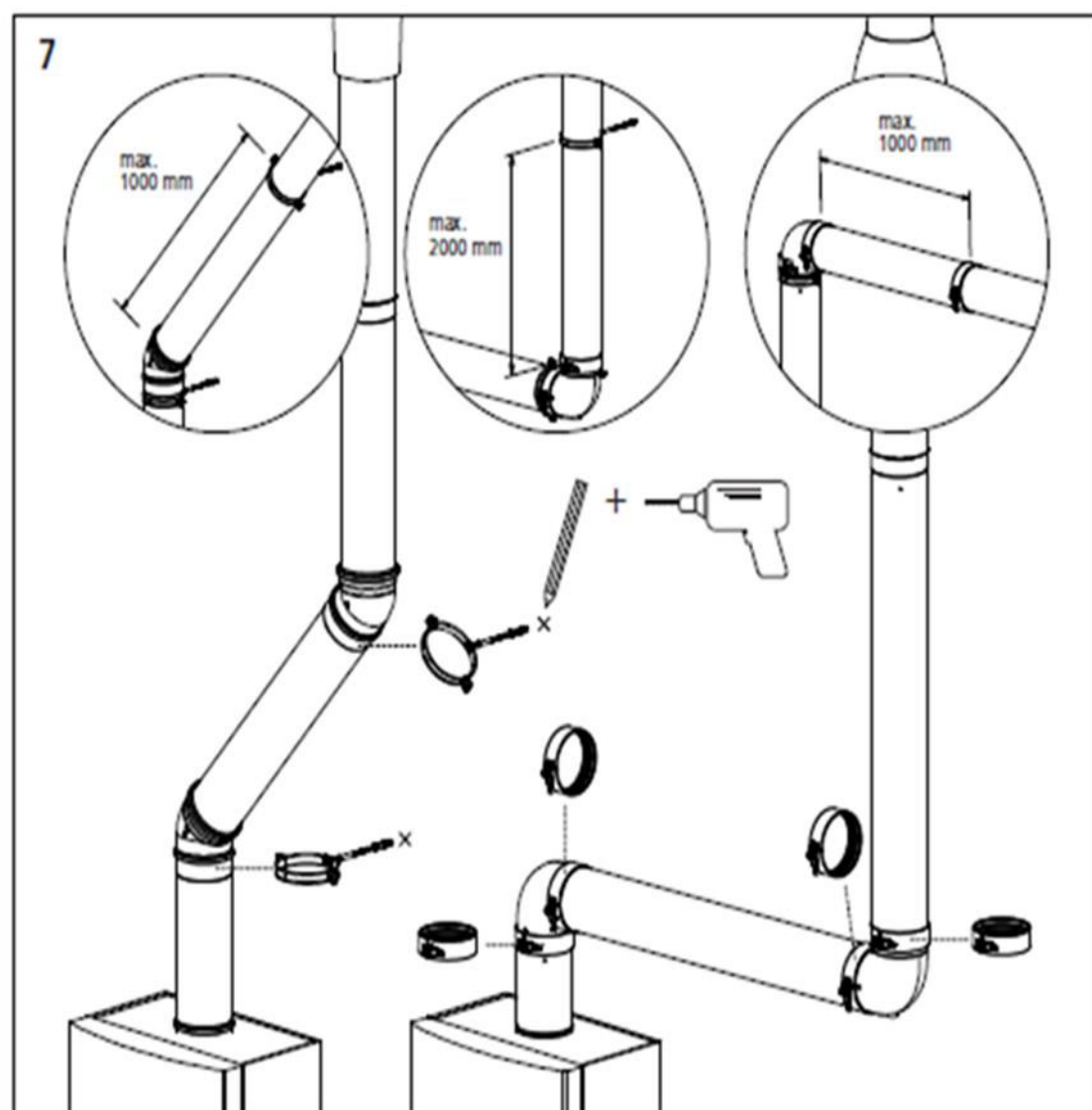

8.6.11 Maximum Length – Concentric Flue

The maximum length of the flue system is determined by the resistance of the components within the flue.



The resistance must not exceed 200 Pa.



The information shown in table 8.6.12 is for the Lochinvar supplied flue system only; other flue system suppliers may have different values.

	CPM 58 (80/125)	CPM 77 (80/125)	CPM 96 (100/150)	CPM 116 (100/150)	CPM 144 (100/150)	CPM 175 (100/150)
Wall terminal	13	22	19	24	40	48
Roof terminal	34	61	39	45	69	86
Straight tube (m)	9	12	8	10	14	16
45° Elbow	5	7	8	9	14	16
90° Elbow	8	13	11	13	22	28

8.6.12 Concentric Flue Component Resistances (Pa)

8.6.13 Worked Example – Concentric Flue

Flue Resistance Calculation Example

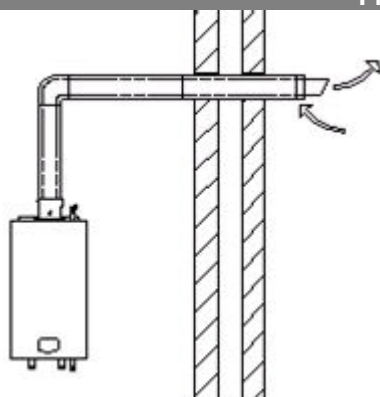

EXAMPLE A

CPM96 BOILER WITH HORIZONTAL CONCENTRIC TERMINAL
3000mm VERTICAL FLUE LENGTH
6000mm HORIZONTAL FLUE LENGTH
90° BEND

EXAMPLE B

CPM144 BOILER WITH HORIZONTAL CONCENTRIC TERMINAL
3000mm VERTICAL FLUE LENGTH
600mm HORIZONTAL FLUE LENGTH
90° BEND

100/150mm Concentric flue

Example A			
Item	Quantity	Resistance	Total
Wall terminal	1	19	19
Roof terminal	0	39	0
Straight tube (m)	9	8	72
45° Elbow	0	8	0
90° Elbow	1	11	11
Total Resistance (Pa)			141
141 < 200 FLUE SYSTEM DESIGN HAS PASSED			
Example B			
Item	Quantity	Resistance	Total
Wall terminal	1	40	40
Roof terminal	0	69	0
Straight tube (m)	9	14	126
45° Elbow	0	14	0
90° Elbow	1	22	22
Total Resistance (Pa)			228
228 > 200 FLUE SYSTEM DESIGN HAS FAILED USE TWIN PIPE OR CONVENTIONAL FLUE INSTEAD			

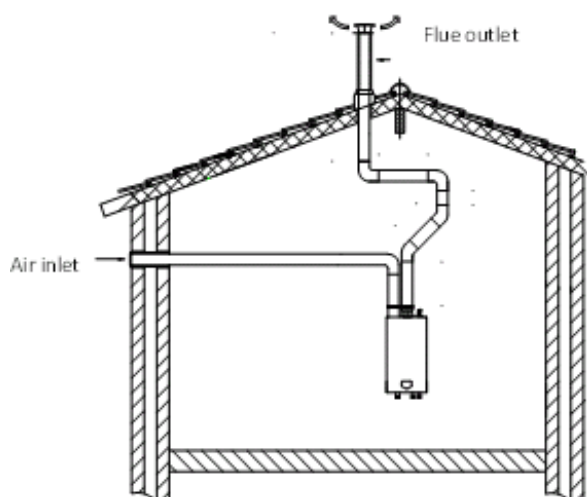

FLUE SYSTEM SPECIFICATION

- MANUFACTURER MUELINK & GROL
- TEMPERATURE CLASS T120
- FLUE GAS MATERIAL PP

VARIOUS FLUE ITEMS ARE AVAILABLE SEE FLUE ASSEMBLY AND ANCILLARIES GUIDE AT WWW.LOCHINVAR.LTD.UK

8.7.1 C₅₃ Twin Pipe Flue System Components

In order to install the CPM boiler in a Twin-pipe configuration models CPM58-CPM116 require a Twin-pipe conversion kit as below, further flue ancillary items are available to complete the installation.

Model	Conversion kit Item number
CPM58	E61-001-162
CPM77	E61-001-163
CPM96	E61-110-164
CPM116	E61-001-164



When installing the boiler as a type C₅₃ appliance, it should be noted that the terminals must not be installed on opposite sides of the building.



Due to the large Flue pipe size required Lochinvar does not supply Twin-Pipe flue components for models CPM144, CPM175. For this installation type a flue system designer/installer should be consulted.

8.7.2 General Twin-Pipe Installation Guidelines

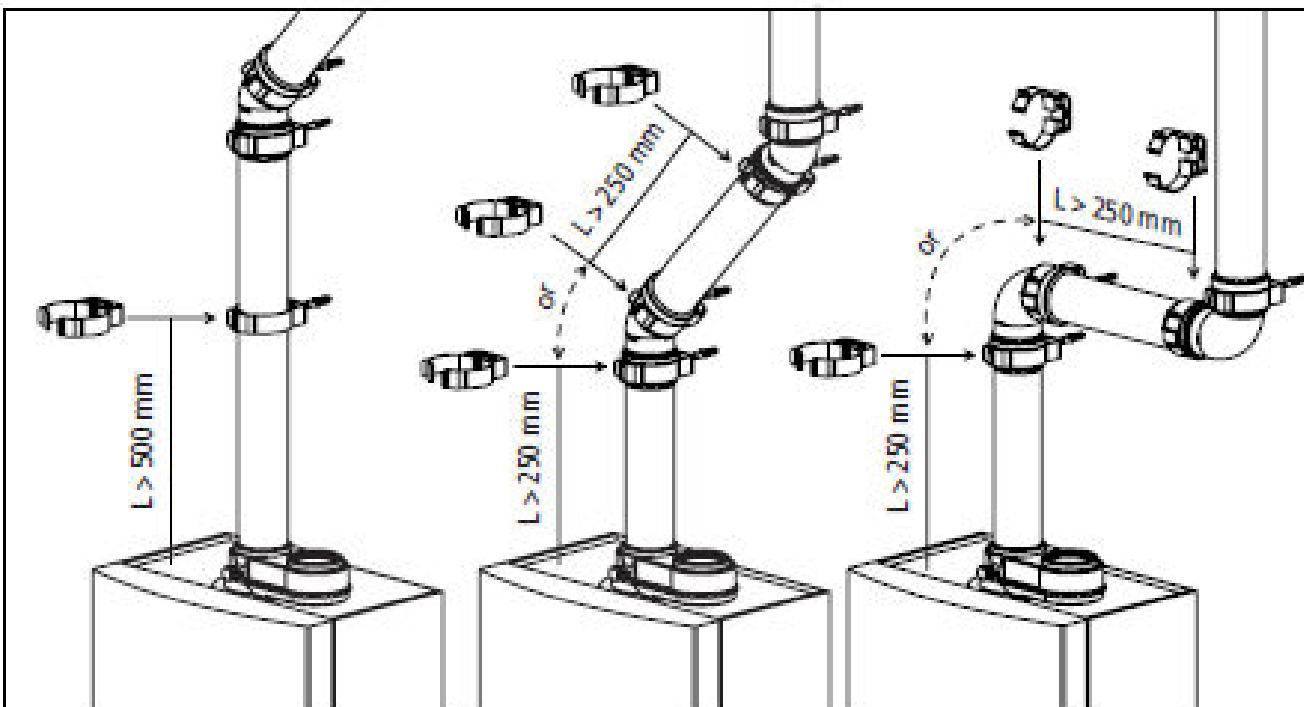
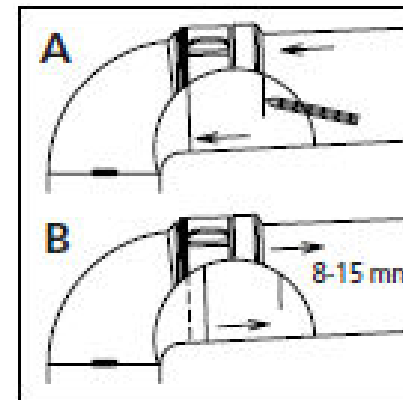
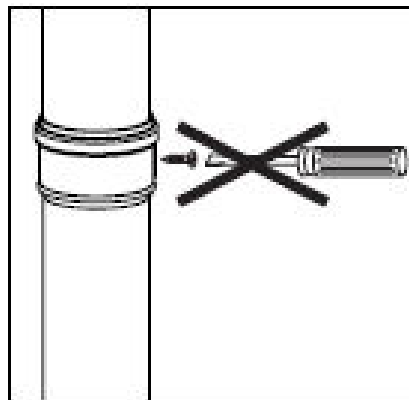
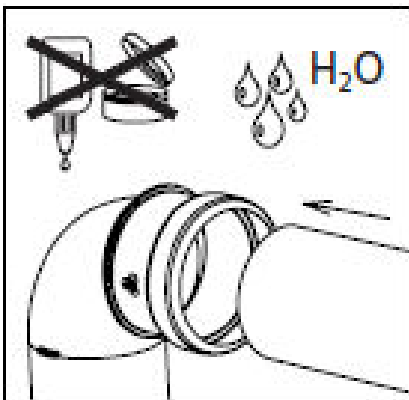
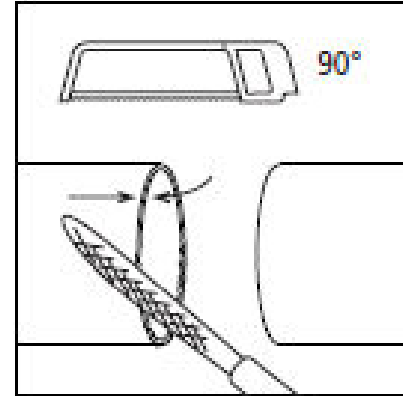
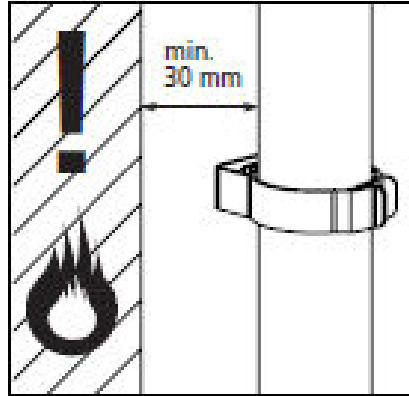
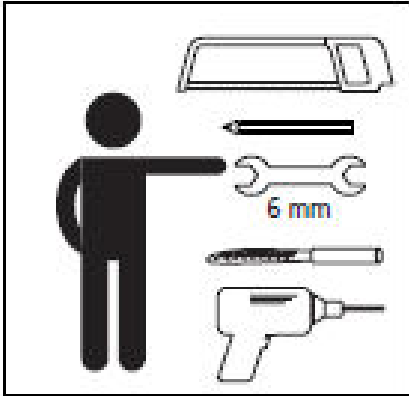

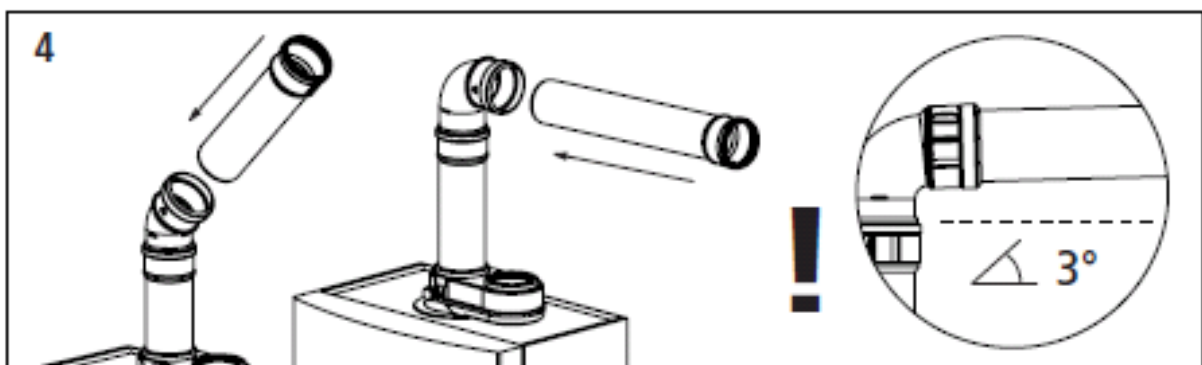
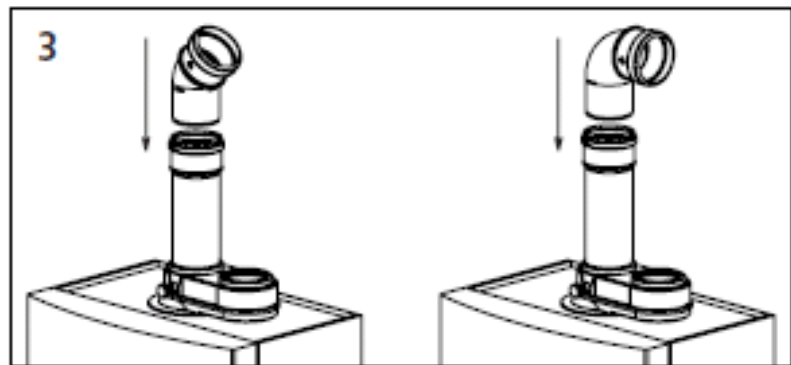
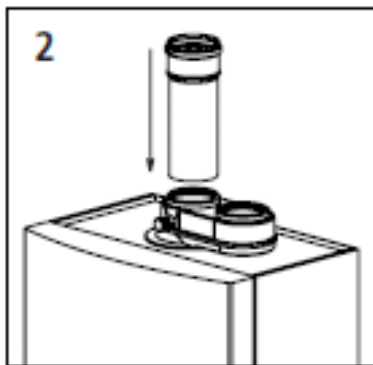
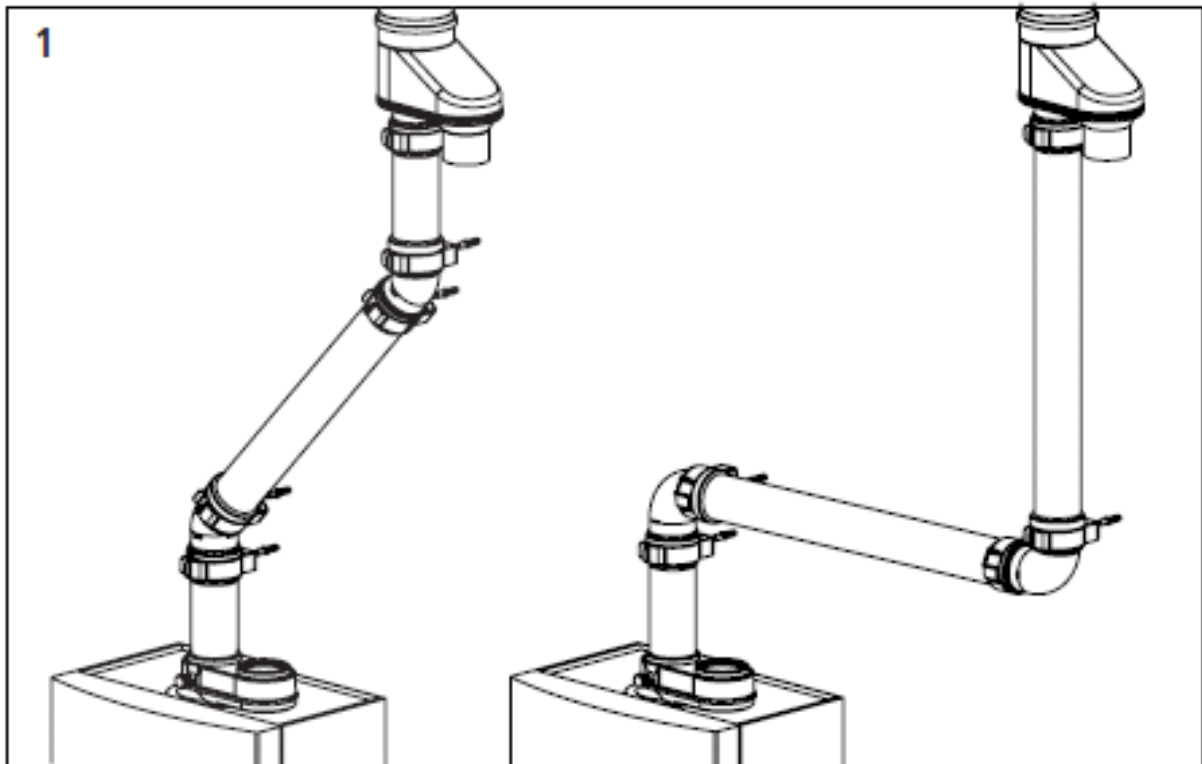

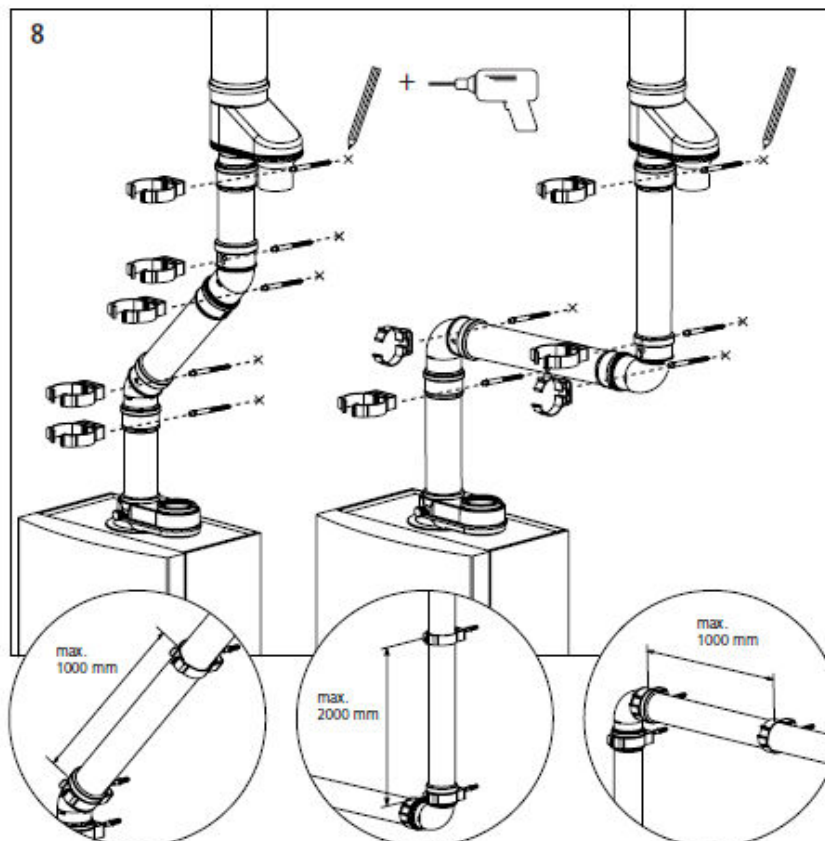
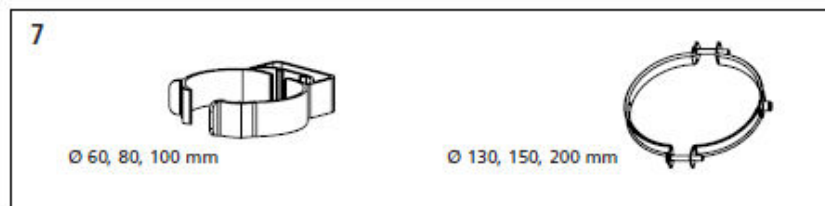
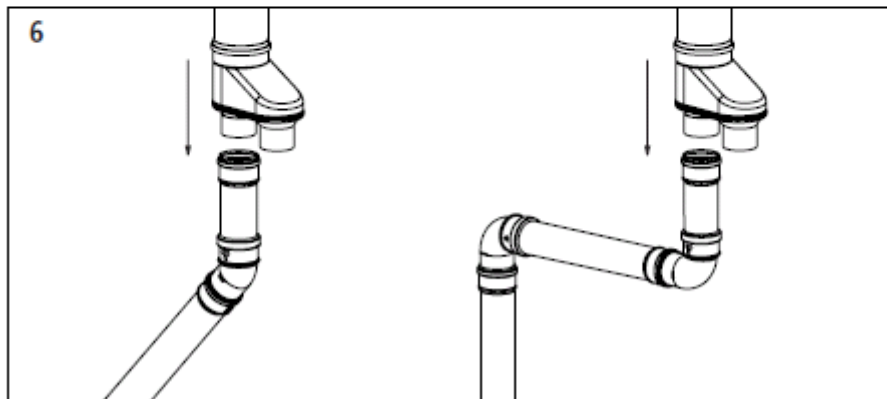
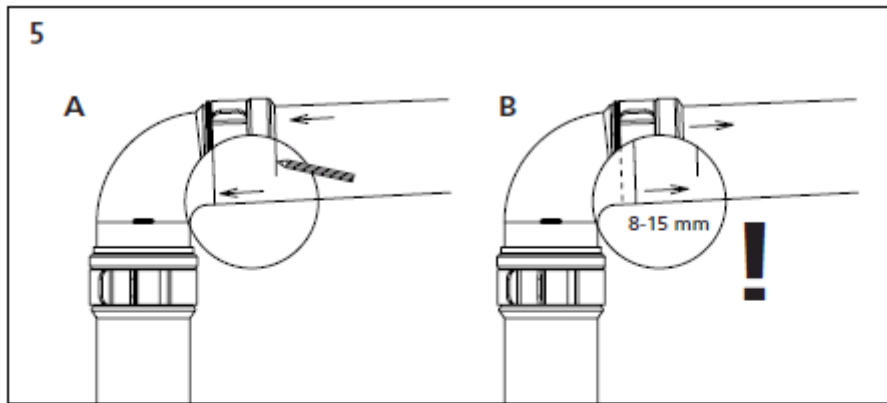

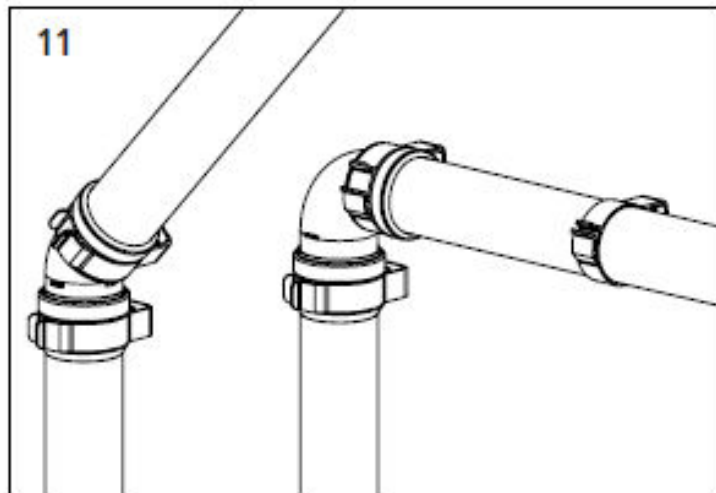
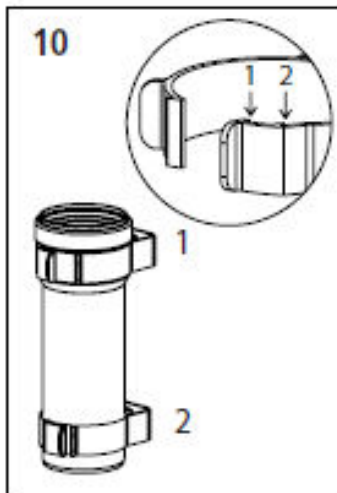
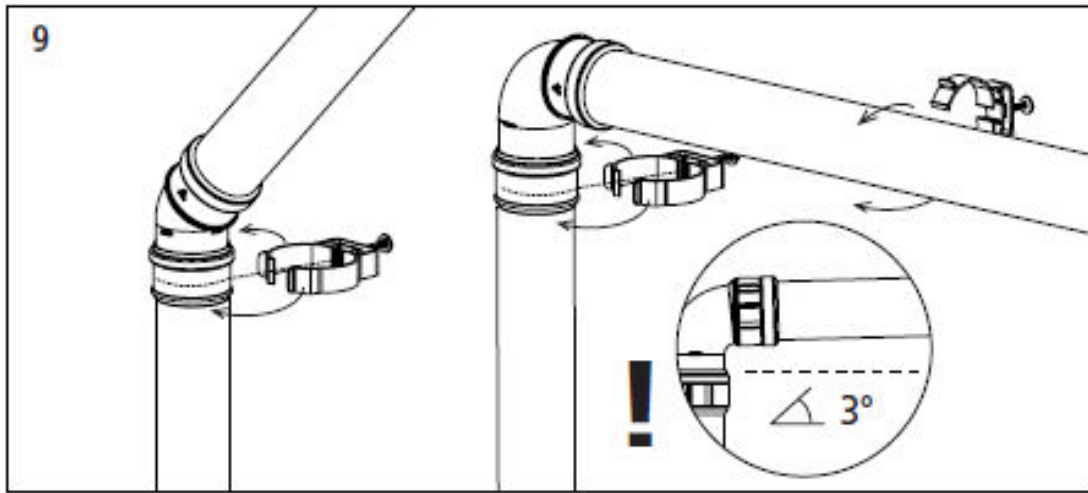

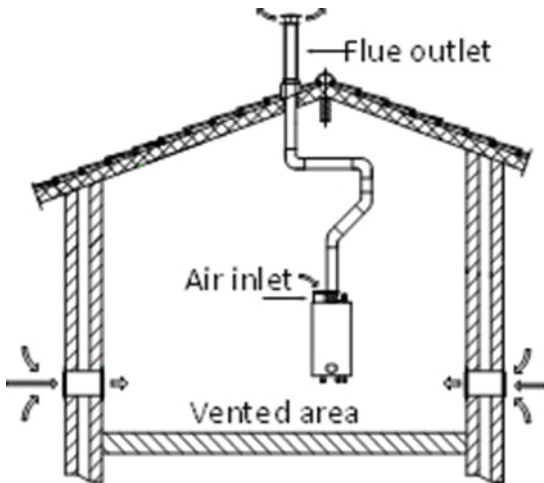

FLUE SYSTEM SPECIFICATION

- MANUFACTURER MUELINK & GROL
- TEMPERATURE CLASS T120
- FLUE GAS MATERIAL PP

VARIOUS FLUE ITEMS ARE AVAILABLE SEE FLUE ASSEMBLY AND ANCILLARIES GUIDE AT WWW.LOCHINVAR.LTD.UK

8.8.1 B₂₃ Conventional Flue System Components

When installing as a fan assisted conventional flue appliance models CPM58-CPM116 require a Twin-pipe conversion kit and additionally require an Air inlet guard as below.

Model	Conversion kit Item number	Air Inlet guard Item number
CPM58	E61-001-162	M73039B
CPM77	E61-001-163	M73039B
CPM96	E61-110-164	M86787B
CPM116	E61-001-164	M86787B

When installing as a fan assisted conventional flue appliance models CPM144-CPM175 are factory supplied in a Twin-pipe configuration so only require an Air inlet guard as below

Model	Air Inlet guard Item number
CPM144	M81660B
CPM175	M81660B



Due to the large Flue pipe size required Lochinvar does not supply conventional flue components for models CPM144, CPM175 except the air inlet guard. For this installation type a flue system designer/installer should be consulted.

8.8.2 Maximum Length – Conventional/Twin-Pipe Flue

The maximum length of the flue system is determined by the resistance of the components within the flue. When a conventional or twin-pipe flue is to be used, the maximum length of the flue system is limited by the combined resistance of the inlet (if used) and outlet flue components as detailed in the following tables.



The resistance must not exceed 200 Pa.



The information shown in table 8.6.12 is for the Lochinvar supplied flue system only; other flue system suppliers may have different values.

Item	Size (mm)	Resistance (Pa)					
		CPM 58	CPM 77	CPM 96	CPM 116	CPM 144	CPM 175
Straight tube (per metre)	80	4.0	7.5	X	X	n/a	n/a
Straight tube (per metre)	100	1.2	3.0	3.5	4.0	n/a	n/a
Straight tube (per metre)	130	0.4	0.7	0.8	1.1	n/a	n/a
45° Elbow	80	2.0	3.5	X	X	n/a	n/a
45° Elbow	100	0.6	1.5	1.7	2.0	n/a	n/a
45° Elbow	130	0.2	0.4	0.4	0.5	n/a	n/a
90° Elbow	80	4.0	7.0	X	X	n/a	n/a
90° Elbow	100	1.2	3.0	3.5	4.0	n/a	n/a
90° Elbow	130	0.3	0.7	0.8	1.1	n/a	n/a
Vertical inlet cap	80	10.4	18.1	X	X	n/a	n/a
Vertical inlet cap	100	4.2	7.4	11.4	16.7	n/a	n/a
Vertical inlet cap	130	1.5	2.6	4.0	5.8	n/a	n/a

8.8.3 Air Inlet Component Resistances (Pa)

Item	Size (mm)	Resistance (Pa)					
		CPM 58	CPM 77	CPM 96	CPM 116	CPM 144	CPM 175
Straight tube (per metre)	80	5.0	8.0	X	X	n/a	n/a
Straight tube (per metre)	100	2.0	3.5	4.0	6.5	n/a	n/a
Straight tube (per metre)	130	0.5	0.8	1.2	1.8	n/a	n/a
45° Elbow	80	2.5	4	X	X	n/a	n/a
45° Elbow	100	1.0	1.7	2	3.2	n/a	n/a
45° Elbow	130	0.2	0.4	1.6	0.8	n/a	n/a
90° Elbow	80	5.0	8.0	X	X	n/a	n/a
90° Elbow	100	2.0	3.5	4.0	6.5	n/a	n/a
90° Elbow	130	0.4	0.8	1.2	1.8	n/a	n/a
Vertical exhaust cap	80	13.8	24.0	X	X	n/a	n/a
Vertical exhaust cap	100	5.6	9.8	15.2	22.1	n/a	n/a
Vertical exhaust cap	130	2.0	3.5	5.3	7.8	n/a	n/a

8.8.4 Exhaust Component Resistances (Pa)

8.8.5 Worked Example – Conventional Flue

Flue Resistance Calculation Example

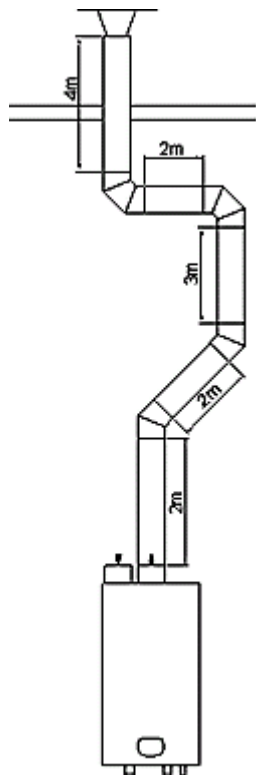

EXAMPLE CPM96 BOILER WITH VERTICAL CONCENTRIC TERMINAL
 11000mm VERTICAL FLUE LENGTH
 2000mm HORIZONTAL FLUE LENGTH
 2X 90° BEND
 2X 45° BEND
 AIR SUPPLY FROM PLANT ROOM

100mm flue pipe

Item	Quantity	Resistance	Total
Straight tube (m)	13	4.0	52.0
45° Elbow	2	2.0	4.0
90° Elbow	1	4.0	4.0
Concentric Vertical terminal	1	86.0	86.0
Total Resistance (Pa)			146
Total Resistance 146<200 FLUE SYSTEM DESIGN HAS PASSED			

8.8.6 WORKED EXAMPLE – TWIN-PIPE FLUE

Flue Resistance Calculation Example

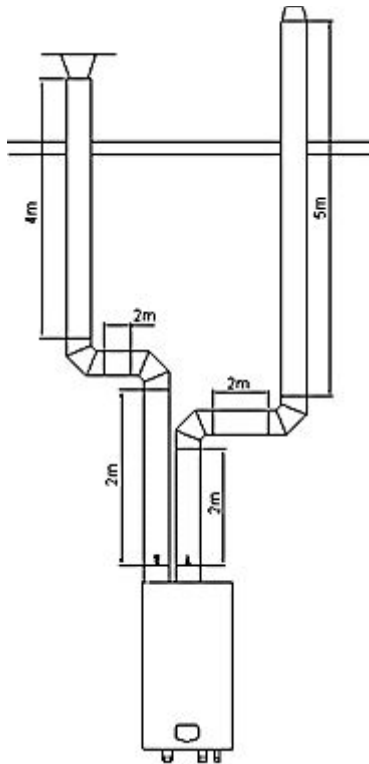

EXAMPLE CPM1116 BOILER
 FLUE EXHAUST
 7000mm VERTICAL FLUE LENGTH
 2000mm HORIZONTAL FLUE LENGTH
 2X 90° BEND
 1X CONCENTRIC FLUE TERMINAL
 AIR INLET
 6000mm VERTICAL LENGTH
 2000mm HORIZONTAL LENGTH
 2X 90° BEND
 1X AIR INLET

110mm flue and air inlet pipe

	Item	Quantity	Resistance	Total
Flue exhaust	Straight tube (m)	9	6.5	58.5
	45° Elbow	0		0
	90° Elbow	2	6.5	13
	Concentric Vertical terminal	1	22.1	22.1
	Total Resistance (Pa)			93.6
Air Inlet	Straight tube (m)	8	4	32
	45° Elbow	0		0
	90° Elbow	2	4	8
	Air Inlet	1	16.7	16.7
	Total Resistance (Pa)			56.7
Total Resistance= 93.6+56.7 = 150.3<200 FLUE SYSTEM DESIGN HAS PASSED				

8.9 FLUE DISCHARGE

The flue system must ensure safe and efficient operation of the equipment to which it is attached, protect the combustion process from wind effects and disperse the products of combustion to open external air.

The flue must terminate in a freely exposed position and be so situated as to prevent the products of combustion entering any opening in a building.

For further information on terminal locations, please refer to **Section 8.3**.

8.10 TYPE B₂₃ (CONVENTIONAL FLUE)

To convert the CPM 58 – CPM 116 to conventional flued operation, the approved air intake grille should be fitted to the concentric flue spigot. The grille will have an opening in the top plate that allows the connection of the flue system to the exhaust port of the boiler.

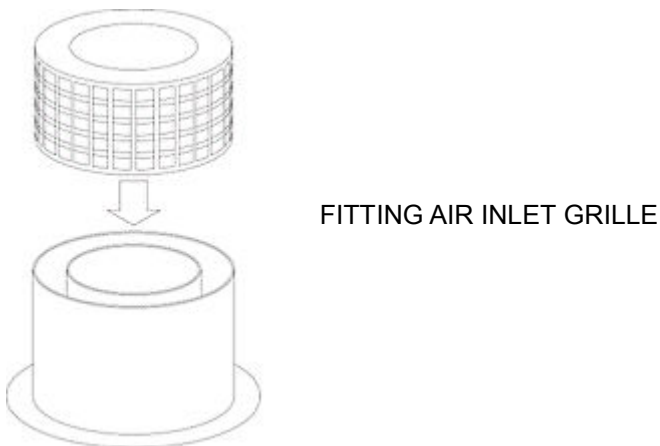

When the heater is installed as a Type B₂₃ appliance, the flue system should be installed in accordance with the flue manufacturer's specific instructions.

8.11 CONVENTIONAL AND TWIN-PIPE FLUE TERMINATION (FLAT AND TILED ROOFS)

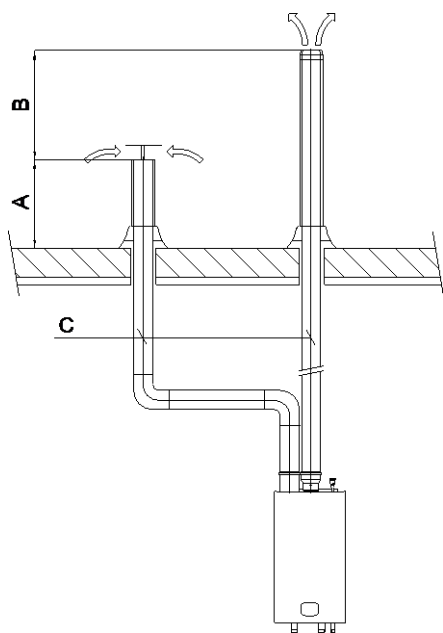

Height A

This is the height of the air inlet. A rain hood should prevent rain-water entering the air supply system.

When the inlet and outlet are mounted on a flat roof, the inlet should be at least 60 cm above the roof surface and at least 30 cm above the maximum snow level.

Example 1:

When the maximum snow level on the roof surface is 45 cm then the air inlet should be at $45+30=75$ cm. 75 cm is more than the minimum 60 so the height will be 75 cm.

Example 2:

When the maximum snow level on the roof surface is 15 cm then the air inlet should be at $15+30=45$ cm. 45 cm is less than the minimum 60 cm so the height will be 60 cm.

Height difference B

This is the distance between the flue outlet and the air inlet.

The flue gas outlet should be at least 70 cm above the air inlet. It is advised to be equipped with a conical outlet.

When no air inlet connection is applied on the roof, the flue outlet should be situated at least 100 cm above the roof surface.

Distance C

The horizontal mutual distance at roof level.

This distance should be at least 70 cm.

8.12 TYPE C₄₃ U DUCT

This appliance can operate on a U-Duct common flue system. The maximum lengths for the interconnecting flue can be calculated using the information in **Section 8.8.2**:

Concrete components of the U-Duct must meet the requirements of **BS EN 1858**

	CPM 58	CPM 77	CPM 96	CPM 116	CPM 144	CPM 175
Flue Gas Mass Rate (G20) 96%(g/sec)	22.6	29.8	37.1	45.1	55.6	67.3
Flue Gas Mass Rate (G20) 25%(g/sec)	5.7	7.5	9.3	11.3	13.9	16.8
Flue Gas Mass Rate (G31) 96%(g/sec)	23.2	30.6	38.8	46.2	57.0	69.0
Flue Gas Mass Rate (G31) 25%(g/sec)	5.8	7.7	9.7	11.6	14.3	17.3

8.12.1 Flue Gas Mass Rates

8.13 COMMON FLUE SYSTEMS

The CPM boiler can be installed on to a common flue system if required. The common flue system should be sized to operate under a negative pressure of -0.03 to -0.10 mbar.

If a positive pressure common flue system is to be used, a proprietary recirculation prevention device must be installed at the flue spigot of each boiler to prevent products of combustion from re-entering the plant room.

A cascaded common flue system which operates on a positive pressure is available from Lochinvar Limited. Further details can be found in the Cascade Flue Systems guide, available from www.lochinvar.Limited.uk.

8.14 FLUE TERMINAL GUARDING

If a Vertical flue terminal is to be fitted less than 2 metres from ground level or in a location where it can be touched from a window, door or balcony, a terminal guard must be fitted.

The terminal guard should be positioned centrally around the terminal and secured using appropriate wall fixings.

8.15 CONDENSATE DRAIN

For flue runs of less than 6 metres, provided that the flue system rises at an angle of at least 3° (50mm per metre), no additional condensate drain will be required. Failure to provide an adequate rise in the flue system may lead to pooling of condensate which may lead to premature failure of the flue system.

If the flue run is greater than 6 metres, it is recommended that an inline condensate drain and trap be fitted. The condensate trap should be connected to a suitable drainage system as described in **Section 6.4**

8.16 C₆₃ CERTIFIED FLUE SYSTEMS

In general boilers are certified with their own purpose supplied Concentric or Twin Pipe flue systems, C63 certified appliances allow the installer to use other flue systems when installing the boiler however they must be of a suitable minimum standard as per **Table 8.16.1**

CE string flue gas material	European standard	Temperature class	Pressure class	Resistance to condensation	Corrosion resistance class	Metal: liner specifications	Soot fire resistance class	Distance to combustible material	Plastics: location	Plastics: fire behaviour	Plastics: enclosure
min. eis PP	EN 14471	T120	P1	W	1		O	30	I of E	C/E	L
min. eis RVS	EN 1856-1	T120	P1	W	1	L20040	O	40			

8.16.1 C₆₃ Flue System Specification

Material	Boiler	d _{nom}	D _{outside}	d _{inside}	L _{insert}
SS	CPM58-CPM77	80	80 +0,3/ -0,7	81 +0,3/ -0,3	50 +2/ -2
SS	CPM96-CPM116	100	100 +0,3/ -0,7	101 +0,3/ -0,3	50 +2/ -2
SS	CPM144-CPM175	130	130 +0,3/ -0,7	131 +0,5/ -0,5	50 +2/ -2
PP	CPM58-CPM77	80	80 +0,6/ -0,6		50 +20/ -2
PP	CPM96-CPM116	100	100 +0,6/ -0,6		50 +20/ -2
PP	CPM144-CPM175	130	130 +0,9/ -0,9		50 +20/ -2



Aluminium flue pipe must not be used on this appliance as it may lead to premature failure of the heat exchanger and will invalidate the warranty.

9 AIR SUPPLY

The following information is based on single boiler installations only. If more than one boiler is being used, **BS6644** should be consulted to calculate the necessary requirements.

9.1 COMBUSTION VENTILATION

When used as a Type C appliance, ventilation for combustion is not necessary as the combustion air is ducted directly from outside.

When used as a Type B appliance, the combustion air requirements are as follows:

Model	Gross Input (kW)	Net Input (kW)	Ventilation (Room) (cm ²)	Compartment (Direct to Outside)		Compartment (To Internal Space)	
				High (cm ²)	Low (cm ²)	High (cm ²)	Low (cm ²)
CPM 58	62.2	56.0	245	277	558	558	1116

9.1.1 Combustion Ventilation Requirements – CPM 58

Model	Gross Input (kW)	Net Input (kW)	Plant Room Summer Use						Enclosure Summer Use					
			Low		Medium		High		Low		Medium		High	
			High (cm ²)	Low (cm ²)	High (cm ²)	Low (cm ²)	High (cm ²)	Low (cm ²)	High (cm ²)	Low (cm ²)	High (cm ²)	Low (cm ²)	High (cm ²)	Low (cm ²)
CPM 77	82.2	74.0	148	296	222	370	296	444	370	740	444	814	518	888
CPM 96	102.2	92.0	184	368	276	458	368	552	458	920	552	1012	644	1104
CPM 116	123.3	111.0	222	444	333	555	444	666	555	1110	666	1221	777	1332
CPM 144	153.3	138.0	276	552	414	690	552	828	690	1377	828	1518	966	1656
CPM 175	184.3	166.0	332	664	498	830	664	996	830	1658	996	1826	1162	1992

9.1.2 Combustion Ventilation Requirements – CPM 77 – CPM 175

9.2 COOLING VENTILATION

When used as a type C appliance, installed in a compartment or an enclosure, cooling ventilation should be provided as follows:

Model	Input (Gross) kW	Input (Net) kW	Enclosure/Compartment (Direct to Outside)		Enclosure/Compartment (To Internal Space)		Boiler Room	
			High (cm ²)	Low (cm ²)	High (cm ²)	Low (cm ²)	High (cm ²)	Low (cm ²)
CPM 58	62.2	56.0	277	277	558	558	N/A	N/A
CPM 77	82.2	74.0	370	370	740	740	148	148
CPM 96	102.2	92.0	458	458	920	920	184	184
CPM 116	123.3	111.0	555	555	1110	1110	222	222
CPM 144	153.3	138.0	690	690	1377	1377	276	276
CPM 175	184.3	166.0	830	830	1658	1658	332	332

9.2.1 Cooling Ventilation Requirements

When used as a type B appliance, provision for cooling ventilation is included in the combustion ventilation allowance.

9.3 MECHANICAL VENTILATION

In situations where combustion air cannot be provided by the means of ventilation grilles, it can be supplied by a fan. The minimum flow rate for the fan should be in accordance with **Table 9.4**.

If required, extract air can also be through the use of a fan. When sizing the extract fan, the extract flow rate should be calculated by subtracting the difference volume (from **Table 9.4**) from the actual supplied volume of inlet air. If therefore, a larger than required inlet volume is provided, the extract flow rate will need to be increased accordingly.

If the ventilation discharge from the plant room is through the means of simple openings relying on thermal effects, the minimum free areas of the openings and any associated grilles should be as specified for natural ventilation (see **Section 9.1**:). The ventilation openings shall be at high level and the air supply shall be at low level.



Ventilation must not be provided through natural inlet and Mechanical extract as this will cause a negative pressure within the plant room and may lead to the products of combustion being drawn into the plant room.

Appliance Type	Flow rate per kW total rated net input (m ³ /h)	
	Minimum Inlet Air (Combustion, Ventilation)	Difference between Inlet and Extract Air (Inlet minus Extract Ventilation)
Without draught diverters. (with or without draught stabilisers)	2.58	1.35 ± 0.18

9.3.1 Mechanical Ventilation Flow Rates

9.3.2 Worked Example – Mechanical Inlet/Natural Discharge

Lochinvar CPM 96

Heat input (net): = 92.0 kW

Minimum combustion air flow rate: = $92.0 \times 2.6 \text{ m}^3/\text{h} = 239.2 \text{ m}^3/\text{h}$

Ventilation grille size (high level): = 184 cm^2

9.3.3 Worked Example – Mechanical Inlet/Service Mechanical Discharge (Minimum Combustion Air Flow Rate)

Lochinvar CPM 96

Heat input (net): = 92.0 kW

Minimum combustion air flow rate: = $92.0 \times 2.6 \text{ m}^3/\text{h} = 239.2 \text{ m}^3/\text{h}$

Difference between inlet and extract air (maximum value): = $92.0 \times (1.35 + 0.18) \text{ m}^3/\text{h} = 140.76 \text{ m}^3/\text{h}$

Difference between inlet and extract air (minimum value): = $92.0 \times (1.35 - 0.18) \text{ m}^3/\text{h} = 107.64 \text{ m}^3/\text{h}$

Extract air (maximum value): = $239.2 \text{ m}^3/\text{h} - 107.64 \text{ m}^3/\text{h} = 131.56 \text{ m}^3/\text{h}$

Extract air (minimum value): = $239.2 \text{ m}^3/\text{h} - 140.76 \text{ m}^3/\text{h} = 98.44 \text{ m}^3/\text{h}$

9.3.4 Worked Example – Mechanical Inlet/Service Mechanical Discharge (Alternate Combustion Air Flow Rate):

Lochinvar CPM 96

Heat input (net): = 92.0 kW

Minimum combustion air flow rate: = $92.0 \times 2.6 \text{ m}^3/\text{h} = 239.2 \text{ m}^3/\text{h}$

Actual combustion air flow rate: = $92.0 \times 3.15 \text{ m}^3/\text{h} = 289.8 \text{ m}^3/\text{h}$

Difference between inlet and extract air (maximum value): = $92.0 \times (1.35 + 0.18) \text{ m}^3/\text{h} = 140.76 \text{ m}^3/\text{h}$

Difference between inlet and extract air (minimum value): = $92.0 \times (1.35 - 0.18) \text{ m}^3/\text{h} = 107.64 \text{ m}^3/\text{h}$

Extract air (maximum value): = $289.8 \text{ m}^3/\text{h} - 107.64 \text{ m}^3/\text{h} = 182.16 \text{ m}^3/\text{h}$

Extract air (minimum value): = $289.8 \text{ m}^3/\text{h} - 140.76 \text{ m}^3/\text{h} = 149.04 \text{ m}^3/\text{h}$

10 ELECTRICAL INSTALLATION

10.1 GENERAL

All wiring is connected to the terminal block within the appliance casing. The terminal block can be found on top of the display panel and can be accessed by removing the boiler front door and the connector protection cover.

- For operation the boiler needs a power supply of 230 Vac 50Hz.
- The boiler connections are not live/neutral sensitive (the boiler is not phase-sensitive).
- All wiring to/from the boiler should be sited through the bottom of the boiler through the cable glands.
- NOTICE: Before starting to work on the boiler, it must be switched off and the power supply to the boiler must be disconnected.
- Wiring external to the equipment must be installed in accordance with the I.E.E. Regulations and any local regulations that apply.



**A suitably competent person MUST check wiring. Normal supply required is 230 volts AC, single phase, 50 Hz. An isolator with a contact separation of at least 3mm in all poles should be sited close to the equipment and must only serve that equipment. The double pole switch must be readily accessible under all conditions.
WARNING: THIS APPLIANCE MUST BE EARTHED**

10.2 ELECTRICAL CONNECTIONS

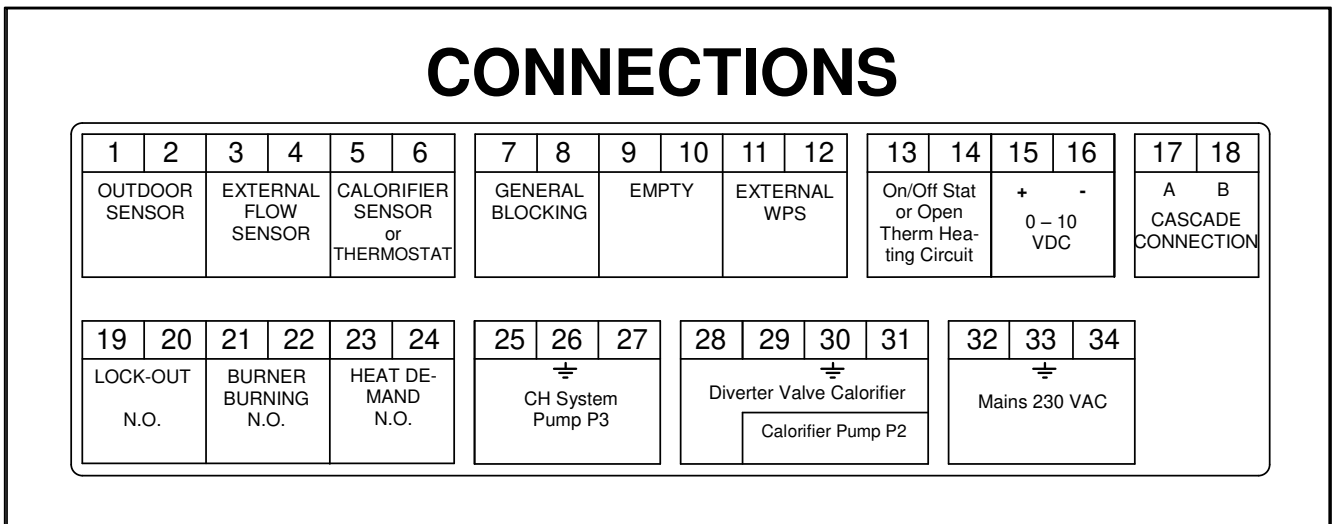

10.3 CONNECTION DETAILS

1-2	OUTDOOR SENSOR
When an outside temperature sensor is connected, the boiler set point will be compensated in relation to the outside temperature. The addition of this sensor will reduce the flow temperature of the boiler in warmer temperatures, increasing energy efficiency. PARAMETER: No parameter settings needed.	
3-4	EXTERNAL FLOW SENSOR
When a low loss header is used, this sensor measures the flow temperature at the system side. The sensor must be mounted on the supply pipe at the system side, just behind the low loss header. NOTICE: The sensor must be used when boilers are cascaded with the internal cascade manager. PARAMETER: No parameter settings needed.	
5-6	INDIRECT DHW CYLINDER SENSOR or THERMOSTAT
When an Indirect DHW Cylinder is installed, a hot water sensor must be connected to these terminals. In case of a DHW heat demand, the set point will be shown in the display. An external on/off thermostat can also be connected to these terminals. When there is heat demand (terminals 5 and 6 are bridged) the flow temperature going to the heating coil(s) will be shown in the display.	

7-8	GENERAL BLOCKING
A heat demand that will start the burner will be blocked when terminals 7 and 8 are not bridged. This connection is for the use of external safety devices (terminals must be bridged to allow burner to fire).	
9-10	EMPTY
11-12	EXTERNAL WATER PRESSURE SWITCH
A water pressure sensor is mounted in the boiler. As an option a water pressure switch can be installed. The sensor can be replaced by the water pressure switch, which can be wired to the terminals. When terminals 11-12 are not bridged, the boiler will lock-out. PARAMETER: A parameter change is needed.	
13-14	ON/OFF STAT OR OPENTHERM HEATING CIRCUIT
OPTION 1: An ON/OFF thermostat can be connected. The boiler will use the set/programmed flow temperature for the heating system when these terminals 13 and 14 are bridged. OPTION 2: An OpenTherm (OT) controller can be connected to the terminals 13 and 14. The boiler software will detect and use this OpenTherm signal automatically.	
15-16	0-10 VDC CONTROL SIGNAL
These terminals are used for an external 0-10 VDC control signal. PARAMETER: A parameter change is needed. NOTICE: Terminal 15 [+] (positive) and terminal 16 [-] (negative).	
17-18	CASCADE CONNECTION
These connections are used when boilers are cascaded with the internal cascade manager. NOTICE: Connect all terminals 17 and all terminals 18 together, do not switch between these terminals.	
19-20	LOCK-OUT OR PUMP ON/OFF
This contact is N.O. (normally open). When the unit is in lock-out this contact will close. This contact can also be used for the switching of a pump with a separate control input connection; then a parameter change is needed.	
21-22	BURNER BURNING OR EXTRA BOILER OR PUMP ON/OFF
This contact is N.O. (normally open). When the unit starts the burner and detects the flame, this contact will be closed. This contact can also be used to control an external boiler or for the switching of a pump with a separate control input connection; in both latter cases a parameter change is needed.	
23-24	HEAT DEMAND OR PUMP ON/OFF
This contact is N.O. (normally open). When the unit receives any heat demand this contact will close. This contact can also be used for the switching of a pump with a separate control input connection; then a parameter change is needed.	
25-26-27	CH SYSTEM PUMP P3
Connections for a central heating system pump (P3). Nominal pump current of P3 may not exceed 2 A, therefore its power may not exceed 458 W, see also § 0.	
28-29-30-31	DIVERTER VALVE INDIRECT DHW CYLINDER
When using a Indirect DHW Cylinder, a 3-way valve or a pump (P2) can be used to divert hot water to the heating coil of the Indirect DHW Cylinder. This 3-way valve will open, when the Cylinder has a heat demand. PARAMETER: A parameter change is needed. 28 = L1 wire (heating position); 29 = Neutral wire; 30 = Ground wire; 31 = L2 wire (hot water position). The inrush current of the 3-way valve may not exceed 3 A, see also § 0.	
29-30-31	INDIRECT DHW CYLINDER PUMP P2
When using a Indirect DHW Cylinder, a 3-way valve or a pump (P2) can be used to divert hot water to the heating coil of the Indirect DHW Cylinder. This pump will start when the Cylinder creates a hot water demand. PARAMETER: A parameter change is needed. Nominal pump current of P2 may not exceed 2 A, therefore its power may not exceed 458 W, see also § 0.	
32-33-34	POWER SUPPLY
The power supply connection of the unit. 32 = Phase wire; 33 = Ground wire; 34 = Neutral wire.	

10.4 ELECTRICAL SCHEMATICS

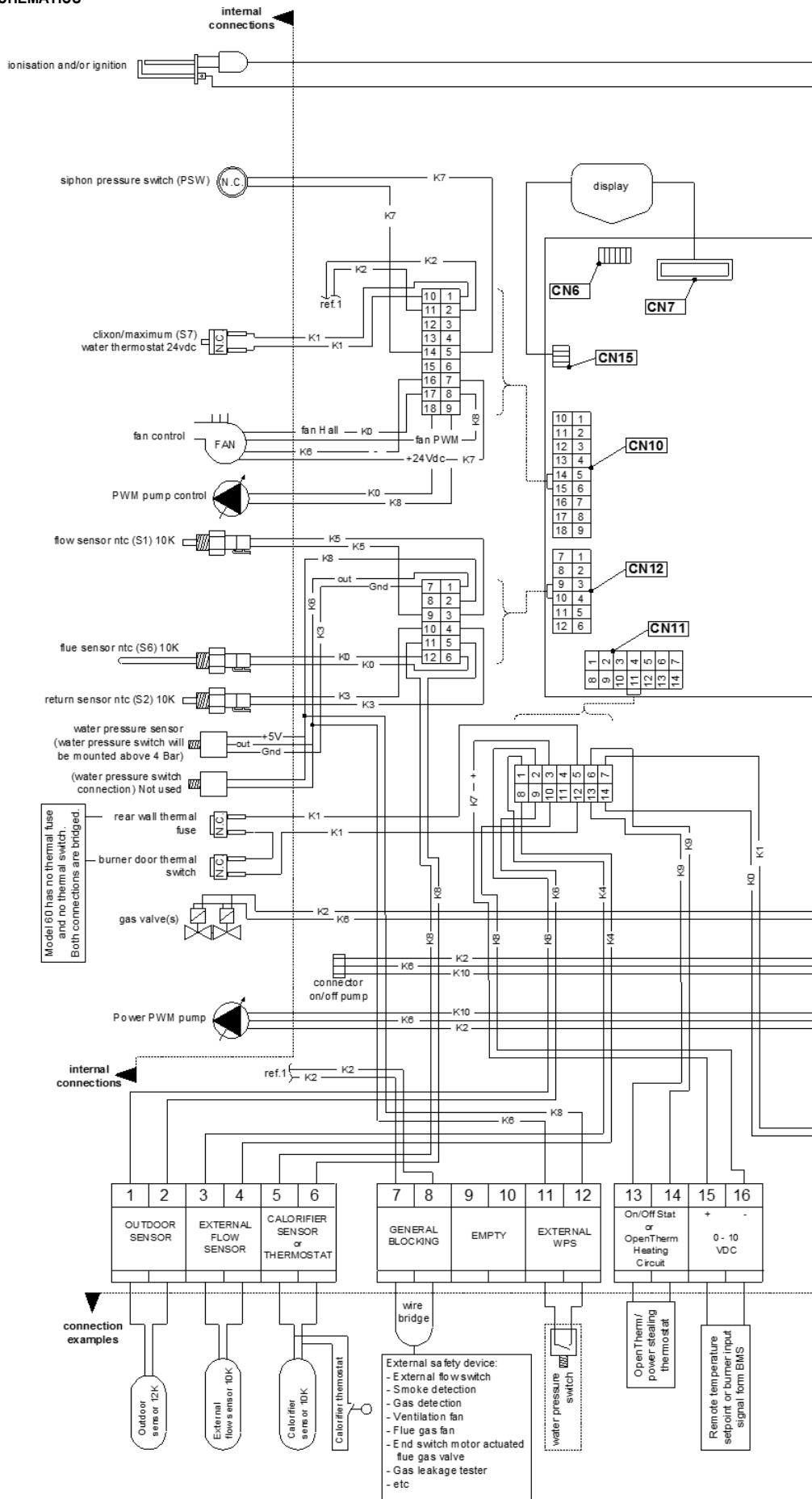

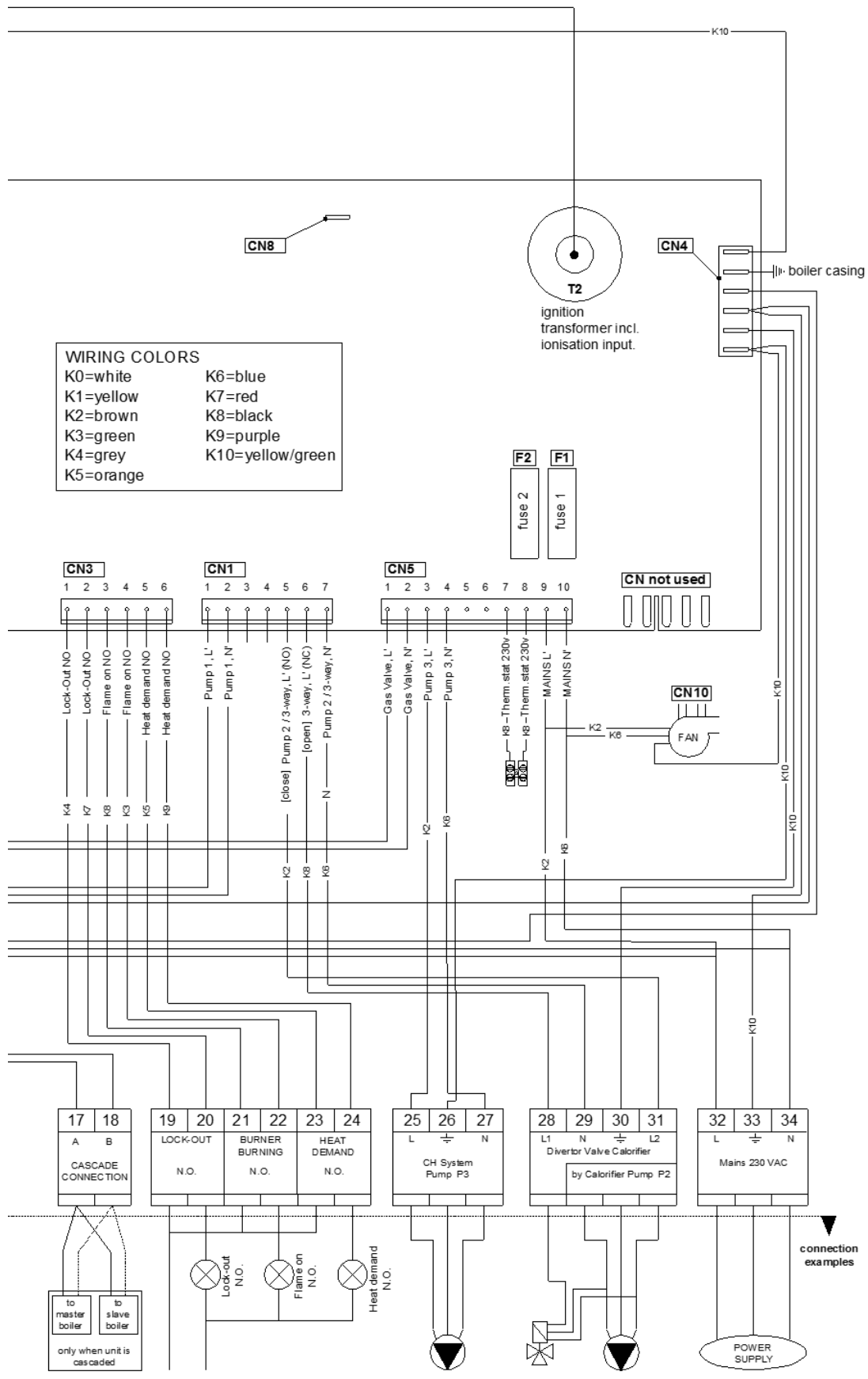

10.5 SENSOR VALUES

SENSOR	SENSOR TYPE	SENSOR VALUE
S1	internal flow sensor	NTC-10K-B3977
S2	internal return sensor	NTC-10K-B3977
S3	external flow sensor	NTC-10K-B3977
S4	Indirect DHW Cylinder sensor	NTC-10K-B3977
S5	outdoor sensor	NTC-12K-B3740
S6	flue gas sensor	NTC-10K-B3977

Temperature (°C)	Resistance (Ω)	Temperature (°C)	Resistance (Ω)
-50		0	36130
-45		5	28577
-40		10	22770
-35		15	18300
-30	171750	20	14770
-25	129770	25	11600
-20	98930	30	9774
-15	75820	35	7754
-10	58877	40	6652
-5	45950	45	5522

10.5.1 Conversion table temperature vs. resistance outdoor sensor NTC-12k B3740

Temperature (°C)	Resistance (Ω)	Temperature (°C)	Resistance (Ω)	Temperature (°C)	Resistance (Ω)	Temperature (°C)	Resistance (Ω)
-30	175203	20	12488	70	1753	116	387
-25	129289	25	9600	75	1481	125	339
-20	96358	30	7759	77	1256	130	298
-15	72502	35	6535	85	1070	135	262
-10	55047	40	5330	90	915	140	232
-5	42158	45	4372	95	786	145	206
0	32555	50	3585	96	677	144	183
5	25339	55	2989	105	586	155	163
10	19873	58	2490	110	508	158	145
15	15699	65	2084	115	443	165	130

10.5.2 Conversion table temperature vs. resistance all sensors except outdoor sensor. NTC-10k B3977

11 USER INTERFACE

11.1 CONTROL PANEL / DISPLAY UNIT

CONTROL PANEL

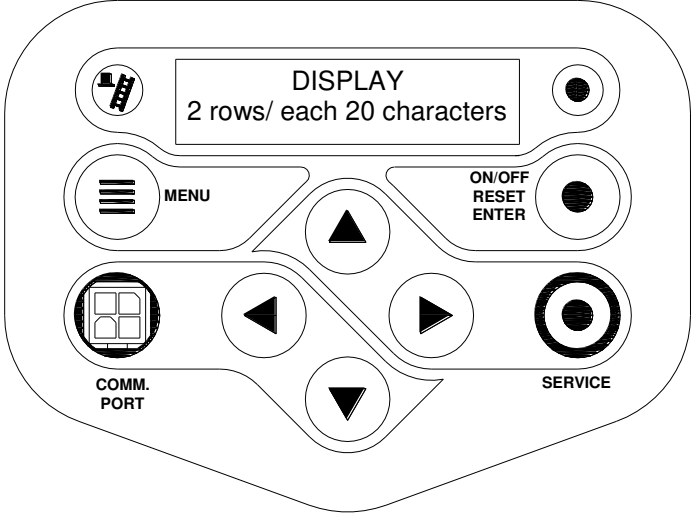











DISPLAY
2 rows/ each 20 characters

MENU

COMM. PORT

**ON/OFF
RESET
ENTER**

SERVICE

 ON/OFF RESET ENTER	<p>Press and hold for three seconds for stand-by/progr. mode Press and hold for six seconds to switch boiler on/off. Is also used as RESET button and ENTER button when programming.</p>
 COMM. PORT	<p>Connector for connecting computer cable.</p>
MENU 	<p>Button is pushed to open MENU.</p>
 	<p>Buttons to toggle through measured temperatures. Also used for navigating through the menus and for changing values.</p>
 	
 SERVICE	<p>Button to activate service function (Hold for three seconds).</p>
	<p>Schornsteinfeger function (only for use in Germany).</p>
	<p>Light: lights when controller detects stable flame signal. Lights when burner is burning.</p>

HOW TO CONFIRM CHANGES

When changes have been made in one of the nine menus below, the user presses ENTER to confirm these changes. To prevent anyone from making changes by mistake, the following happens when changes are made:

Step 1: The user presses [ENTER] to confirm the change made or [MENU] to exit the menu without changes. HINT: First programme all changes planned, then only after that, press [ENTER]
Step 2: The display asks the user to be sure to make these changes. The user can cancel or confirm by using the left and right arrows.

CANCEL = ◀ CONFIRM = ▶

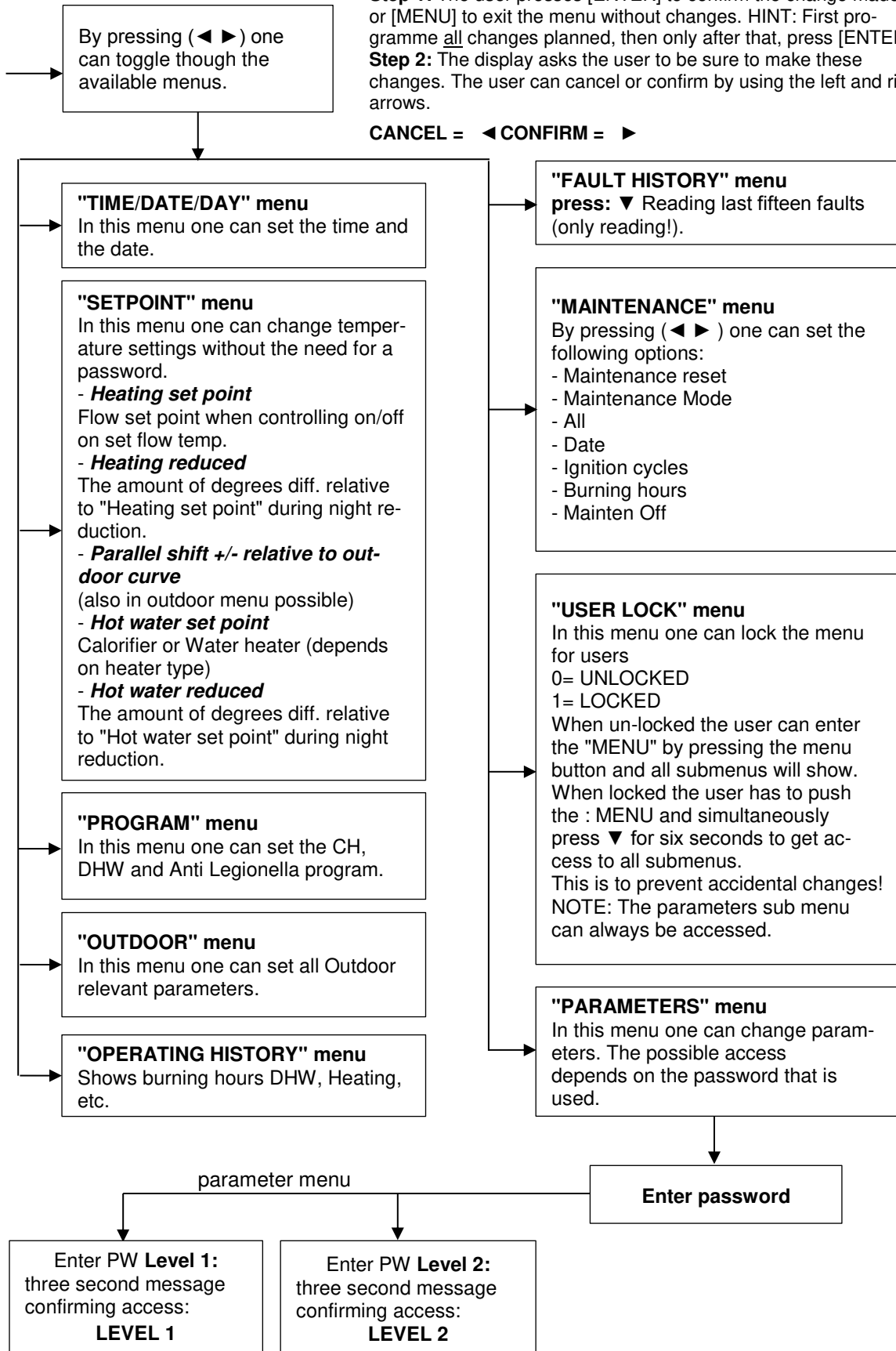

11.3 DISPLAY DURING OPERATION

During normal operation the text in the display shows the status of the boiler. The following pages show the displays that may be seen.

Display at HEATING DEMAND

Heat demand type:				Actual status:			
H	E	A	T	:	N	o	d
>	>	>	:	1	2	3	.
cascade communication indicator				temp. set point		control sensor showing the measured temperature. Can be turned off by P5 BJ	

When heat is required for the Indirect DHW Cylinder the text "HEATING" changes into "HOTWATR".
When there is no heat demand it always shows heating.

Display at HOT WATER DEMAND

Heat demand type:				Actual status:			
H	O	T	W	:	N	o	d
>	>	>	:	1	2	3	.
cascade communication indicator				temp. set point Thermostat > coil flow temp. Sensor > water temp.		control sensor showing the measured temperature Can be turned off by P5 BJ	

Explanation "Actual status" screen

Actual status:
B o i l e r o f f
When boiler is switched off (only text in the display during this status).
N o d e m a n d
No heat demand signal coming from the room thermostat and Indirect DHW Cylinder sensor (open).
S t a n d - b y
Room thermostat & Indirect DHW Cylinder sensor/thermostat detect heat demand but set point is reached.
P r e - p u r g e
The fan is purging before a burner start attempt.
P r e - i g n i t i o n
Ignition starts before opening of the gas valve.
I g n i t i o n
The ignitor is igniting.
P o s t - p u r g e
The fan is purging after burner is switched off.
B u r n i n g 1 0 0 %
When the burner is firing, also the actual rpm% is shown.

Explanation "Cascade communication indicator"

NO CASCADE COMMUNICATION

> > > no.1
Always showing the fixed ">>>"

CORRECT CASCADE COMMUNICATION

> > no.1
> > no.2
Showing alternating no.1 & no.2 with one second interval.

11.4 MONITOR SCREENS

During normal operation and stand-by, the [◀] and [▶] buttons can be used to show some boiler information, including measured temperatures, settings and data. The following pages show the values in the display. When no button is activated for 2 minutes, the display will return to its status display.

Pressing [◀] or [▶] while being at the "operating screen" toggles through the screens below. When pressing [ON/OFF], [RESET], [ENTER] or [MENU] at any time the display returns to the base menu.

SCREEN: 1

T 1	F l o w	1 2 3 , 9 ° C	Measured value by the internal flow sensor.
T 2	R e t u r n	1 2 3 , 9 ° C	Measured value by the internal return sensor.
		O p e n	Shown when controller doesn't detect this sensor.
		S h o r t e d	Shown when sensor wires or sensor itself is shorted.

SCREEN: 2

T 3	E x t e r n a l	1 2 3 , 9 ° C	Measured value by the external sensor.
T 4	C a l o r i f i	1 2 3 , 9 ° C	Measured value by the Indirect DHW Cylinder sensor.
		O p e n	Shown when controller doesn't detect this sensor.
		S h o r t e d	Shown when sensor wires or sensor itself is shorted.

SCREEN: 3

T 5	O u t d o o r	1 2 3 , 9 ° C	Measured value by the outdoor sensor.
T 6	F l u e	1 2 3 , 9 ° C	Measured value by the flue gas sensor.
		O p e n	Shown when controller doesn't detect this sensor.
		S h o r t e d	Shown when the sensor wires or the sensor itself is shorted.

SCREEN: 4

d T F l o w R e t u r n	1 2 3 , 9 ° C	Temp difference between internal flow & return sensor.
d T F l u e R e t u r n	1 2 3 , 9 ° C	Temp difference between flue gas & internal return sensor.

SCREEN: 5

d T E x t R e t u r n	1 2 3 , 9 ° C	Temp difference between external & internal return (ΔT LLH).
S i g n a l	P o w e r	External supplied 0-10 Volt dc signal.
	S e t p o i	"Power" = power input control or "Setpoi" = set point control.

SCREEN: 6

F a n s p e e d	9 9 9 9 r p m	Actual fan speed in rpm.
F a n s p e e d	1 0 0 %	Actual fan speed % of maximum allowable fan speed.



The maximum actual RPM may be lower than the maximum RPM set point. The fan may not be able to reach the maximum RPM set point, because of the unit's resistance, which is still correct according to the design of that specific unit.

SCREEN: 7

F l a m e s i g n a l	1 0 0 μ A	Flame signal given in μA.
W a t e r P r e s s u r e	1 , 0 b a r	Shows water pressure when sensor is connected.

SCREEN: 8

P u m p 1 H e a t e r	O f f	Pump 1 (HEATER PUMP) On or Off.
P u m p 1 S i g n a l	1 0 0 %	Modulating signal Pump 1 in (%).

SCREEN: 9

P u m p 2 C a l o r i	O f f	Shows when the Indirect DHW Cylinder pump is "ON" or "OF".
3 - w a y V a l v e H e a t i n g		Signal to the 3-way valve: "HEATING" or "HOTWATER".

SCREEN: 10

P u m p 3 S y s t e m	O f f	Shows when the system pump is "ON" or "OF".
h h : m m D D / M M / Y Y Y Y D a y		hh=hour; mm=minutes; DD=day; MM=month; YYYY=yr; Day o/t week

SCREEN: 11

C	a	s	c		D	e	s	i	g	n				0						0 = MASTER, 1 11 = SLAVES
C	a	s	i	n	f			0	1	2	3	4	5	6	7	8	9	A	B	Displays number, priority and state of cascade boilers.

DESCRIPTION "CASCINFO" Screen 11

Shows the number of boilers connected with the cascade. The Master/Lead boiler is designated as 0. Slave/Lag boilers will be designated 1, 2, 3, 4, 5, 6, 7, 8, 9, A, B. When a "-" is used instead of a number, then that boiler is either not connected, or in a lockout mode and not available for the cascade. When an "x" is used instead of a number, then that boiler is connected, but in lockout mode.

When a "d" is displayed instead of a number, then that boiler is handling a DHW demand.

When the number is flashing, then that boiler is providing heat to the cascade. When the leading boiler is changed according to the set priority change time, then that boiler's address will be shown first in the row of numbers.

Example 1: "3 4 5 - - - - - 0 1 2"

Six are boilers present and nr. 3 has priority.

Example 2: "3 4 x - - - - - d 1 2"

Six boilers are present and nr. 3 has priority. Boiler 0 is heating up an indirect DHW tank. Boiler 5 is present, but in a lock-out.

SCREEN: 12

C	a	s	c		P	o	w	e	r		9	9	9	%		9	9	9	%	% heat demand of total (cascade) power available (%).
D	u	a	l		B	u	r	n	e	r	:				N	o				Heat exchanger equipped with two burners: "Yes" or "No".

SCREEN: 13

M	a	x		T	h	e	r	m						O	p	e	n			Status of the maximum thermostat: "Open" or "Closed".
G	e	n		B	l	o	c	k						C	l	o	s	e	d	Status of the general blocking contact: "Open" or "Closed".

SCREEN: 14

S	i	p	h	o	n		p	r	e	s	s				C	l	o	s	e	d	Status of the siphon pressure switch: "Open" or "Closed".
N	R	V		C	o	n	t	a	c	t					O	p	e	n			Status of the non-return valve contact: "Open" or "Closed".

* REMARK: at screen 14: No N.R.V used in this type of boiler.

11.5 SERVICE FUNCTION

The following graphs describe how to use the service function.

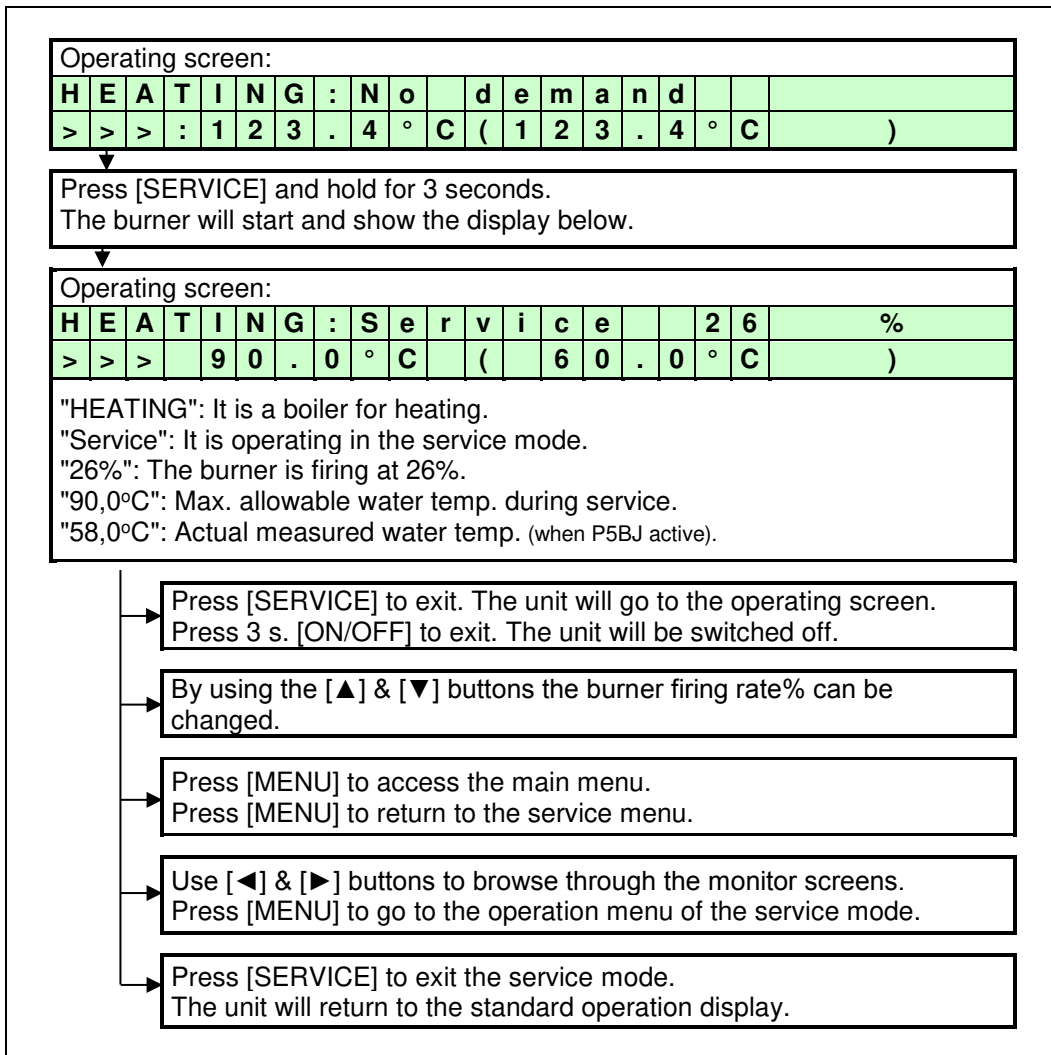

11.6 SCHORNSTEIFEGER FUNCTION (GERMANY ONLY)

Standard factory setting is off, this function is not used in the UK.

11.7 PROGRAMMING IN STANDBY MODE

Standby

Use the standby mode to modifying boiler settings without interacting with the boiler control. Changes are confirmed by leaving standby mode.

Properties of standby mode:

- Keys are active and the menu is accessible.
- Burner does NOT respond to an external heat demand.
- All control functions are active: pumps, fans and cascade are operational, recirculation and frost protection are working.

How to programme the boiler:

- First disconnect or shut down the room thermostat and/or other external controllers from the boiler. The CH pump and fan will stop after a short delay time.
- Switch the boiler into standby mode by pressing [ON/OFF] for three seconds.
- The next display screen should appear:

Display message	H E A T I N G : b o i l e r o f f
	> > > : 1 2 3 . 4 ° C (1 2 3 . 4 ° C)

- Program the boiler at the control panel (see the following sections).
- Terminate programming mode by pressing [MENU], or [ENTER] and NO ◀ or YES ▶.
- Reactivate the boiler by pressing [ON/OFF] for three seconds again.

11.8 SETTING THE TIME & DATE

The following graphs describe how to programme the time and date of the unit.

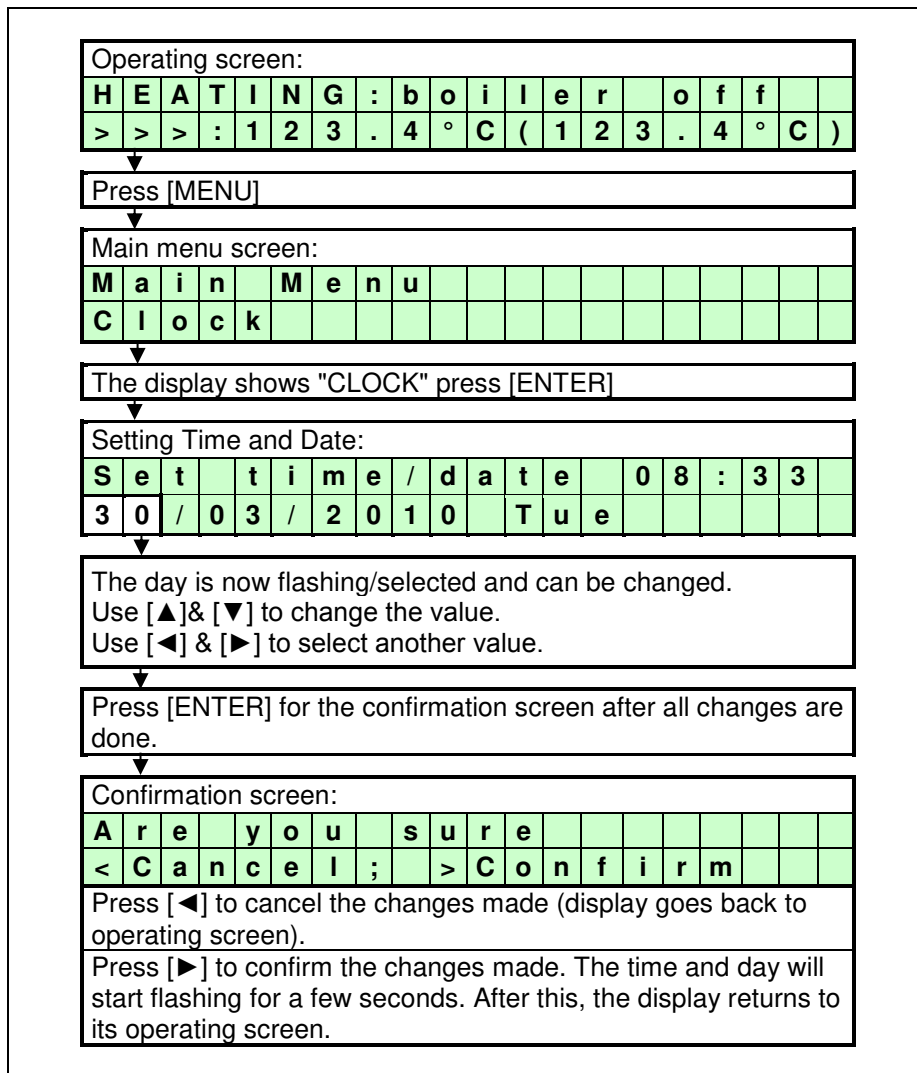

11.9 SET POINTS

The following graphs describe how to program the heating and hot water set points.

NOTICE: The hot water set points are only displayed, when the boiler is programmed as an Indirect DHW boiler. See parameter P4 AA for the exact boiler configuration.

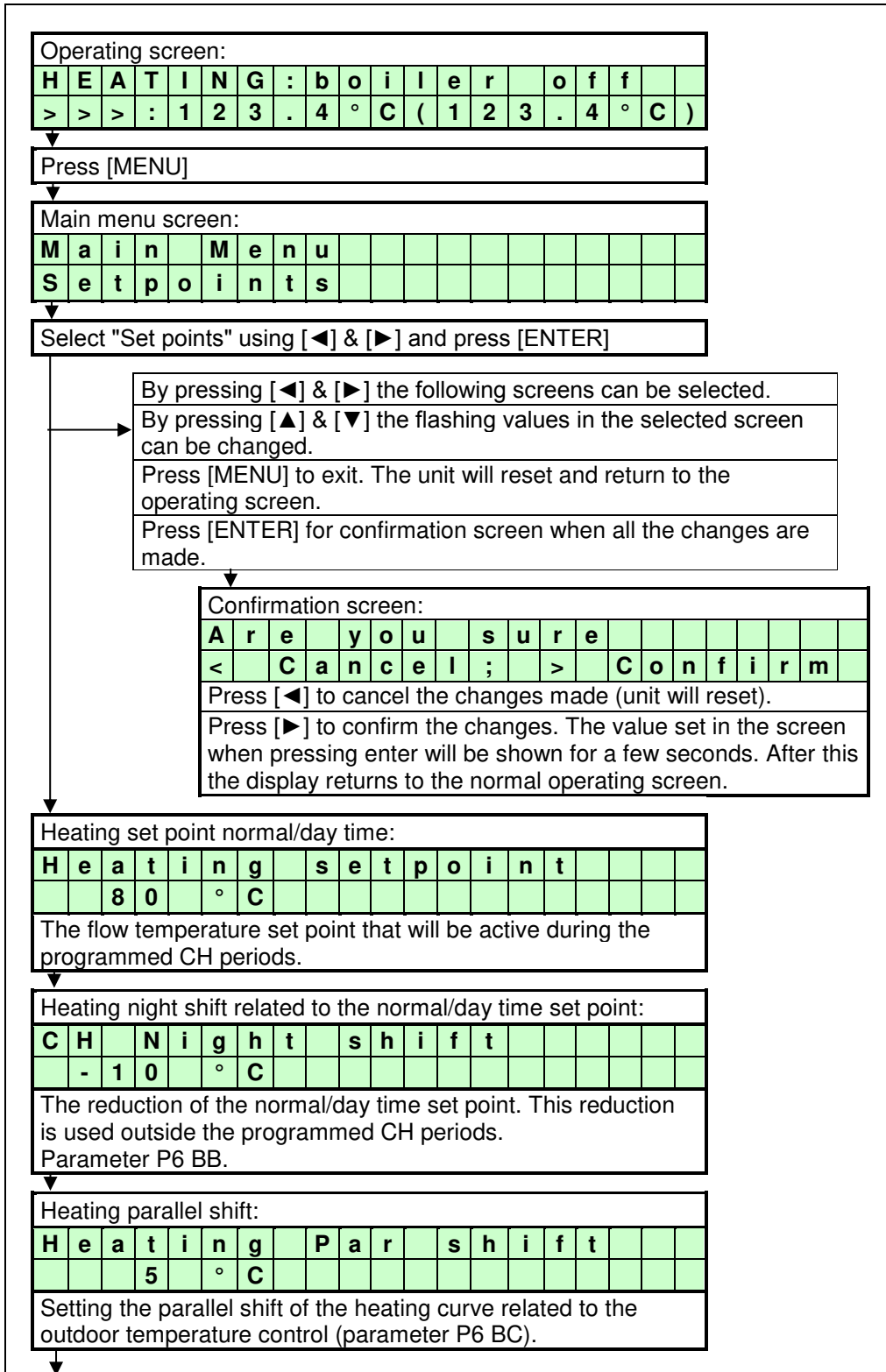

↓

DHW set point normal/day time: (parameter P4 AA = 1/2)												
D	H	W		s	e	t	p	o	i	n	t	
		6	0		°	C						

This is the water temperature set point that is active during the programmed DHW periods (parameter P4 AA = 1/2).

↓

DHW set point reduction: (parameter P4 AA = 1/2)												
D	H	W		R	e	d	u	c	e			
		1	0		°	C						

The reduction of the DHW set point related to normal/day time set point. This reduction is used outside the programmed DHW periods (parameter P4 AA = 1/2).



**The max actual DHW temperature will never exceed the value set at “Heating Setpoint” regardless of the set DHW setpoint.
If a higher DHW setpoint is needed the Heating Setpoint has to be set higher also.**

11.10 SETTING THE TIMER PROGRAMS

Three different programs can be set with the boiler, these are:

- CH program
- DHW program
- Anti-Legionnaires' disease (pasteurisation) program

11.11 HEATING PROGRAM

Three programmed periods each day can be set (period 1, period 2 and period 3). During these periods the unit will use the normal CH and DHW set points. Outside the programmed period(s) the unit will use the reduced temperature as set point. When no time is programmed for a period, it will not be used.

(Example: no time programmed in period 3 on Monday > "**Mon 3 --:-- ---:--**").

Operating screen:

H	E	A	T	I	N	G	:	b	o	i	l	e	r	o	f	f		
>	>	>	:	1	2	3	.	4	°	C	(1	2	3	.	4	°	C)

Press [MENU]

Select "Timer" using [◀] & [▶] and press [ENTER]

Main menu screen:

M	a	i	n	M	e	n	u												
T	i	m	e	r															

Press [ENTER]

Setting CH program times:

P	r	o	g	r	a	m	C	H											
M	o	n	1	0	6	:	0	0	-	2	3	:	0	0					

Press [▶] to browse through the values that can be set at the bottom line. The flashing value can be changed.

Press [▲] & [▼] to change the selected (flashing) value.

Press [ENTER] for confirmation screen when all settings are done.

Confirmation screen:

A	r	e	y	o	u	s	u	r	e									
<	C	a	n	c	e	l	;	>	C	o	n	f	i	r	m			

Press [◀] to cancel the changes made (unit will reset).
 Press [▶] to confirm the changes. The last alternation will be flashing for a few seconds and return to base menu.

Press [MENU] to exit. The boiler will reset and go to the operating screen.

Press [◀] for next SCREEN

Copy programmed day for CH:

C	o	p	y	f	r	o	m	:	C	H					M	o	n
C	o	p	y	t	o	:	C	H							T	u	e

Press [▶] to switch between "Copy from" and "Copy to". The flashing day is selected and can be changed.

Press [▲] & [▼] to change the selected (flashing) value.

Press [ENTER] for confirmation screen when all settings are done.

Confirmation screen:

A	r	e	y	o	u	s	u	r	e									
<	C	a	n	c	e	l	;	>	C	o	n	f	i	r	m			

Press [◀] to cancel the changes made (unit will reset).
 Press [▶] to confirm the changes. The two days will flash for a moment.

Press [MENU] to exit. The boiler will reset and go to the operating screen.

Press [◀] for next SCREEN

>>> Continue on next page HOT WATER program <<<

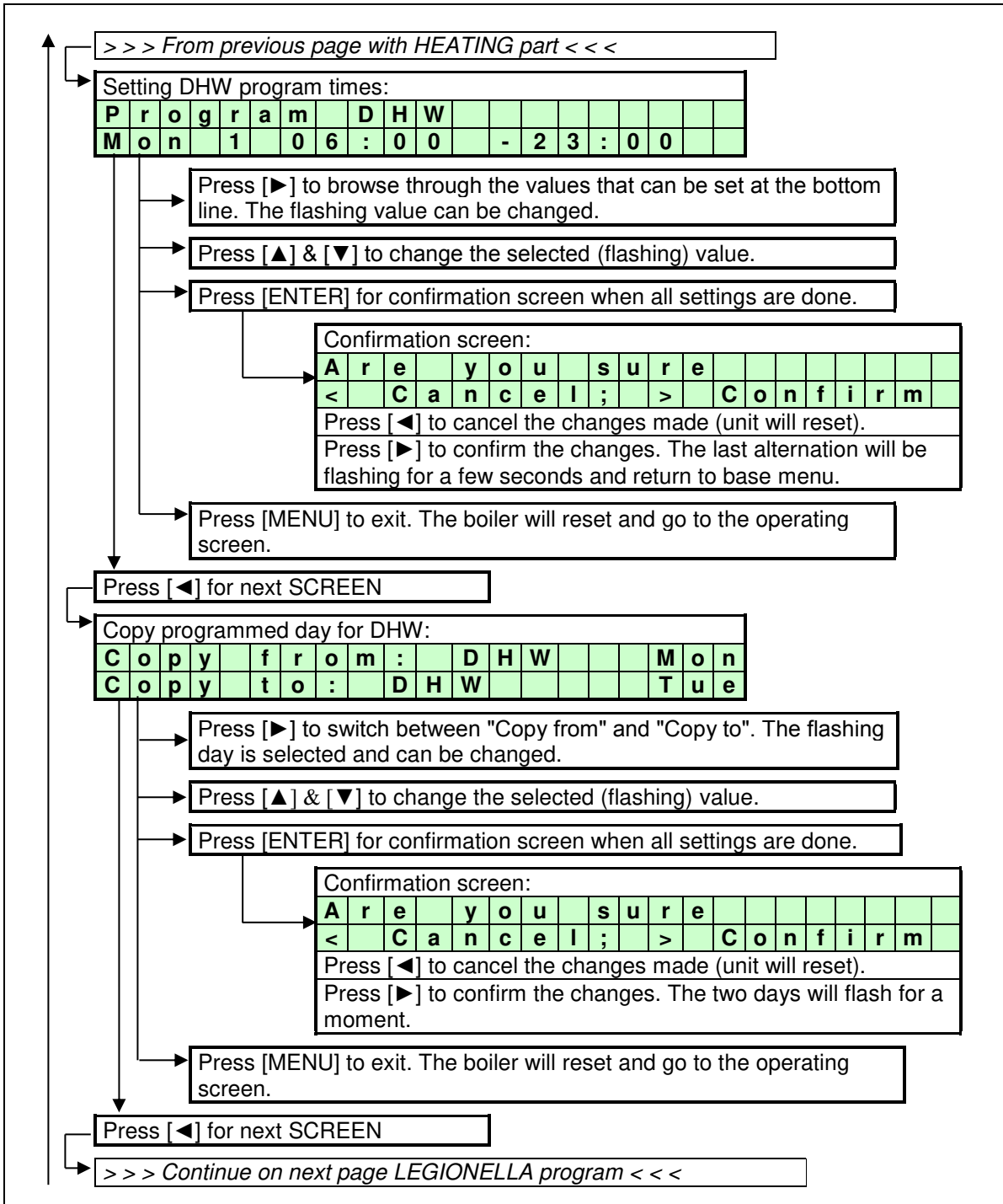

11.13 PASTEURISATION PROGRAM

The pasteurisation program of the boiler can only be used when the boiler is working as an indirect water heater configuration. Only this configuration can activate the day and time program of the pasteurisation function. See the following graphs. The standard factory setting for this function is "OFF".

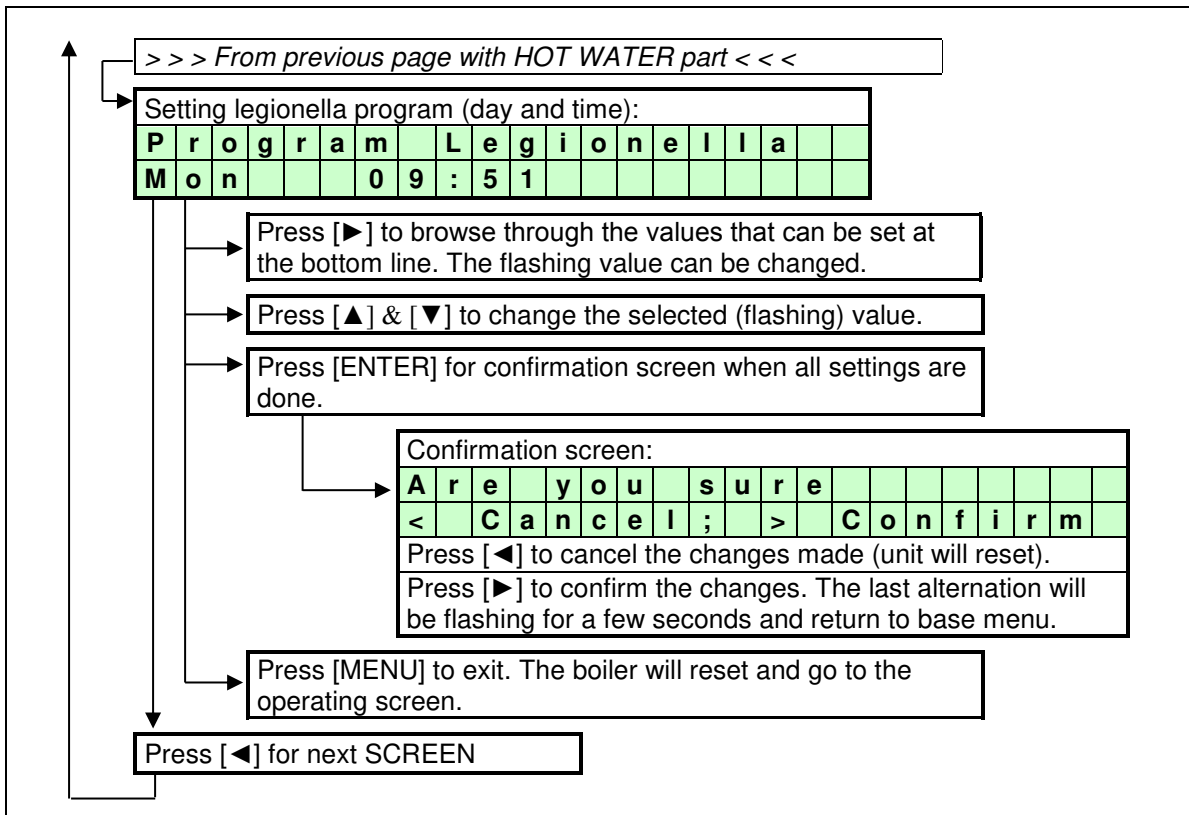

11.14 WEATHER COMPENSATION SETTINGS

11.14.1 Parameters For Setting The Outdoor Graph

When this function is used the flow temperature is calculated based on the measured outdoor temperature. The relation between the outdoor temperature and the flow temperature can be programmed with the following parameters. This setting creates the heating curve.

The boiler will recognise an outdoor sensor when it is connected. When the sensor is detected the boiler controller will control the flow temperature based on the heating curve that is programmed.

P5 AAOutsidPres. (1=On 0=Off)

Outside sensor present.

Setting this parameter to "On" a fault message will be displayed in case of a interrupted connection to the outdoor sensor or if the measured outdoor temperature exceeds 60°C (defective sensor).

0 => No fault message at interrupted outdoor sensor connection. Boiler keeps burning using the value of the external or internal flow sensor instead of the outdoor sensor.

1 => Interrupted sensor wiring causes a fault message to occur at the display Boiler keeps burning using the value of the external or internal flow sensor instead of the outdoor sensor.

OUTDOOR GRAPH (see also next page)

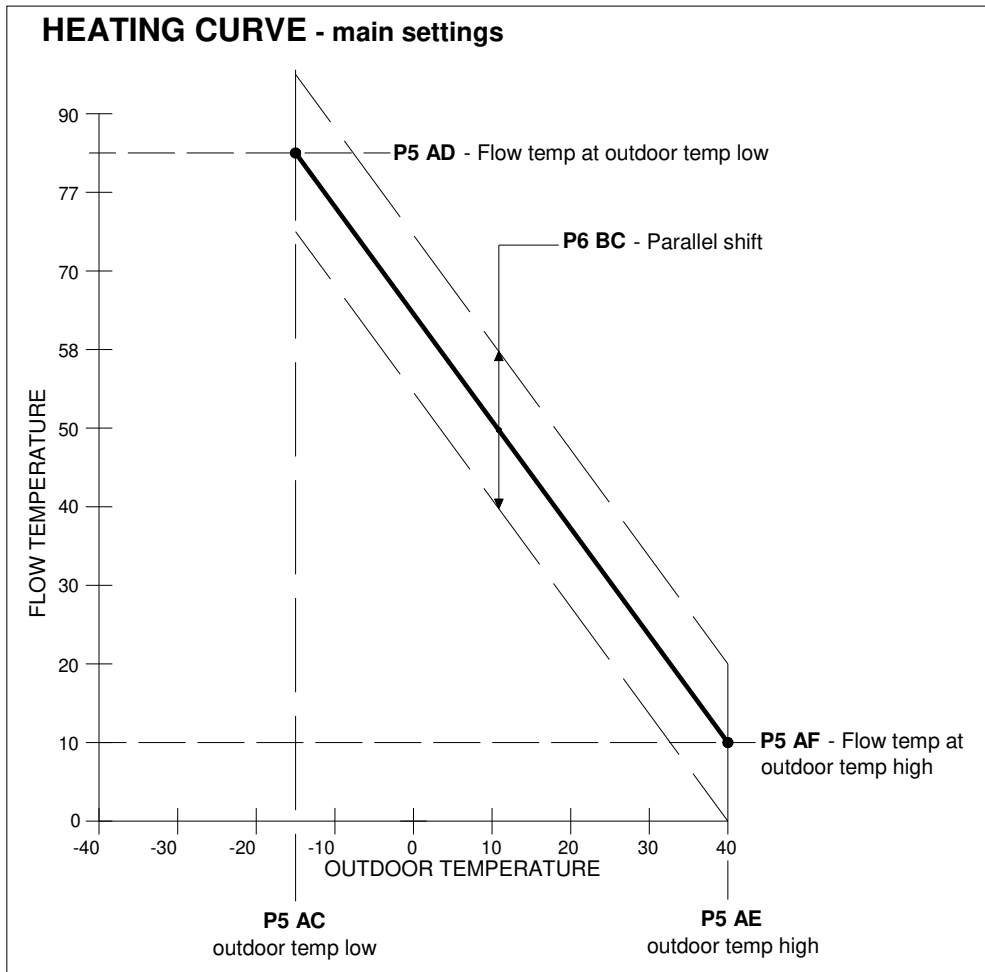

Curve and values only for illustration purposes, programmed parameter values can deviate!

P5 AC Heat curve minimum outdoor temperature (°C)

This sets the minimum outdoor temperature at which one wants the maximum flow temperature that is set.

P5 AD Heat curve flow temperature at minimum (°C)

This sets the desired maximum flow temperature at the set minimum outdoor temperature.

P5 AE Heat curve maximum outdoor temperature (°C)

This sets the maximum outdoor temperature at which one wants the minimum flow temperature that is set.

P5 AF Heat curve flow temperature at maximum (°C)

This sets the desired minimum flow temperature at the set maximum outdoor temperature.

P6 BC Heat curve parallel shift (°C)

The heating curve is set by the parameters. As well as those done by the installer, the end user has the freedom to influence the flow temperature by doing a parallel shift setting. In this parameter the margins are set within which the user can increase and decrease the calculated flow temperature relative to the calculated flow temperature by the heating curve that is set.

Additional settings of the heating curve p.t.o. →

HEATING CURVE - additional settings

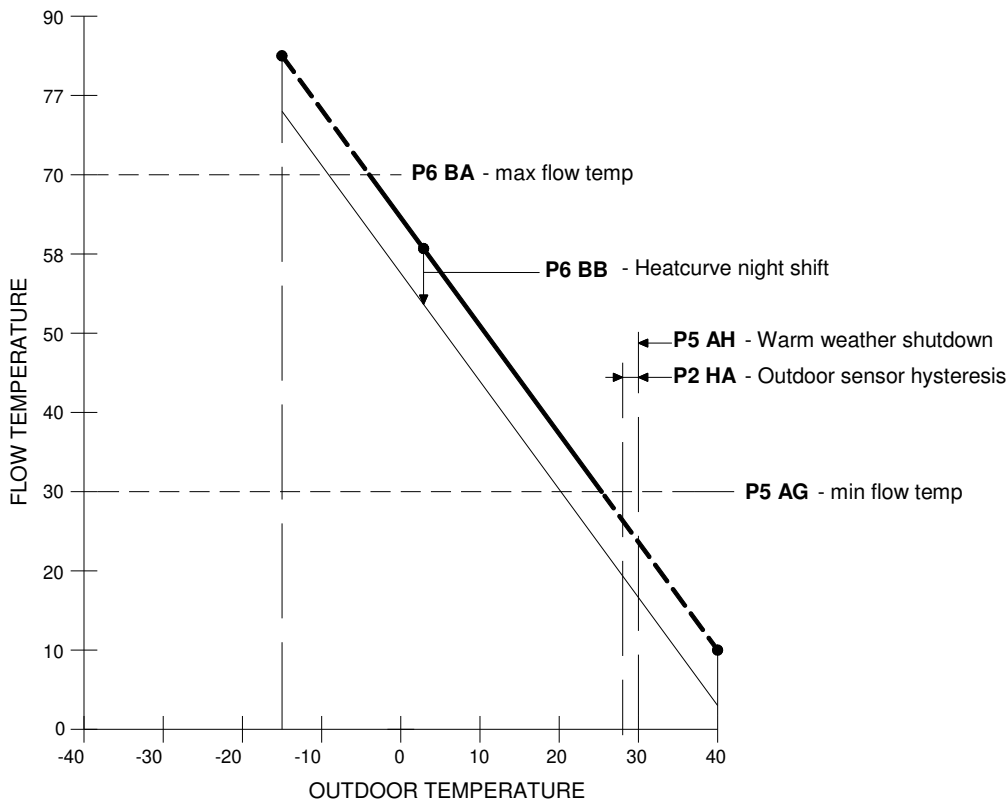

Curve and values only for illustration purposes, programmed parameter values can deviate!

P5 AG Heat curve minimum flow temperature (°C)

The set point will never be lower than the flow temperature set in parameter P5AG. The minimum temperature is limited, even if the calculated set temperature, according to the heating curve, would be lower.

P5 AH Summer outdoor temperature central heating (°C)

If the outdoor temperature is higher than set in P5AH the heat demand for heating will be blocked.

P5AR Outdoor sensor 10K or 12K resistance (1 or 0)

Depending on the type of Outdoor sensor used this parameter can be shifted between 0 and 1. Set to '0' when using a 12k NTC sensor (sensor resistance is 12 kohm at 25°C) Set to '1' when using a 10k NTC sensor (sensor resistance is 10 kohm at 25°C) Default this parameter = 0, it is assumed a 12 kohm sensor will be used.

P2 HA Outdoor sensor hysteresis (°C)

If the outdoor temperature reaches the temperature set in P5 AH (warm weather shutdown) the unit won't start for heating. If the measured outdoor temperature drops P5 AH minus P2 HA the boiler can start up for heating again.

P6 BA CH user setting (°C)

The set point will never be higher than the flow temperature set in parameter P6BA. The maximum temperature is limited, even if the calculated set temperature, according to the heating curve, would be higher.

P6 BB Heat curve night setback (°C)

The temperature reduction during the night, relative to the setting determined by the heat curve

11.15 DISPLAY

The following graphs describe how to program the outdoor graph settings.

Operating screen:																			
H	E	A	T	I	N	G	:	b	o	i	l	e	r	o	f	f			
>	>	>	:	1	2	3	.	4	°	C	(1	2	3	.	4	°	C)
Press [MENU]																			
Select "Outdoor" using [◀] & [▶] and press [ENTER]																			
Main menu screen:																			
M	a	i	n		M	e	n	u											
O	u	t	d	o	o	r													
Press [◀] & [▶] to browse through the screens that are shown below.																			
Press [▲] [▼] to change the flashing value in the selected screen.																			
Press [MENU] to exit. The unit will reset and go to the operating screen.																			
Press [ENTER] for confirmation screen after all changes are made.																			
Confirmation screen:																			
A	r	e		y	o	u		s	u	r	e								
<		C	a	n	c	e	l	;		>		C	o	n	f	i	r	m	
Press [◀] to cancel the changes made (unit will reset).																			
Press [▶] to confirm the changes made. The time and day will start flashing for a few seconds. After this, the display returns to its operating screen.																			
0	1					O	u	t	s	i	d	P	r	e	s				
												0							
P5 AA																			
0	2					H	C	m	i	n	O	u	T	m	p				
											-	1	5	°	C				
P5 AC																			
0	3					H	C	m	i	n	F	I	T	m	p				
											8	5	°	C					
P5 AD																			
0	4					H	C	m	a	x	O	u	T	m	p				
											2	0	°	C					
P5 AE																			
0	5					H	C	m	a	x	F	I	T	m	p				
											2	0	°	C					
P5 AF																			
0	6					H	C	m	i	n	F	I	L	i	m				
											2	0	°	C					
P5 AG																			
0	7					S	u	m	S	h	D	w	n	O	u				
											3	0	°	C					
P5 AH																			
0	8					H	C	m	a	x	F	I	L	i	m				
											8	5	°	C					
P6 BA																			
0	9					H	C	n	g	h	t	s	h	f	t				
											-	1	0	°	C				
P6 BB																			
0	A					H	C	p	a	r	a	s	h	f	t				
												5	°	C					
P6 BC																			
0	B					O	u	t	S	1	2	k	1	0	k				
											0								
P5 AR																			

11.16 CHECKING THE OPERATING HISTORY

The following graphs describe how to check the operating history of the boiler.

Operating screen:

H	E	A	T	I	N	G	:	b	o	i	l	e	r	o	f	f		
>	>	>	:	1	2	3	.	4	°	C	(1	2	3	.	4	°	C)

Press [MENU]

Select "Operate" using [◀] & [▶] and press [ENTER]

Main menu screen:

M	a	i	n		M	e	n	u										
O	p	e	r	a	t	e												

Press [◀] & [▶] to browse through the 5 screens.
 Press [MENU] or [ENTER] to exit. The unit will return to the operating screen.

SCREEN: 1

O	p	e	r	a	t	i	n	g		h	i	s	t	o	r	y					
P	o	w	e	r	O	n				h	r	s				1	3	1	4	0	0

Top line: Shows the operating history menu is activated.
 Bottom line: Total hours the boiler is connected to power supply and switched on.

SCREEN: 2

h	r	s	C	h				T	o	t						1	0	0	0	0	0	0
h	r	s	D	h	w			T	o	t						1	0	0	0	0	0	0

Top line: Total burning hours for heating.
 Bottom line: Total burning hours for domestic hot water.

SCREEN: 3

h	r	s	C	h				<	5	0	%					1	0	0	0	0	0	0
h	r	s	C	h				=	>	5	0	%				1	0	0	0	0	0	0

Top line: Burning hours for heating while the burner was firing less than 50%.
 Bottom line: Burning hours for heating while the burner was firing equal or higher than 50%.

SCREEN: 4

h	r	s	D	h	w			<	5	0	%		:			1	0	0	0	0	0	0
h	r	s	D	h	w			=	>	5	0	%		:		1	0	0	0	0	0	0

Top line: Burning hours for hot water while the burner was firing less than 50%.
 Bottom line: Burning hours for hot water while the burner was firing equal or higher than 50%.

SCREEN: 5

T	i	a		1	0	0	0	0	0	F	i	a				1	0	0	0	0	0	0
S	s	l		1	0	0	0	0	0	S	s	t				1	0	0	0	0	0	6

Top line: Shows Total Ignition Attempts (Tia) & Failed Ignition Attempts (Fia)
 Bottom line: Shows Soft Starts last (Ssl) & Soft Starts Total (Sst)

11.17 CHECKING THE FAULT HISTORY

The following graphs describe how to check the fault history of the boiler.

Operating screen:																			
H	E	A	T	I	N	G	:	b	o	i	l	e	r	o	f	f			
>	>	>	:	1	2	3	.	4	°	C	(1	2	3	.	4	°	C)
Press [MENU]																			
Select "Faulthist" using [◀] & [▶] and press [ENTER]																			
F	a	u	l	t	h	i	s	t						N	o	.	0	1	
2	1	/	0	4	/	2	0	1	0	W	e	d		2	2	:	2	3	A
▲ flashing alternately ▼																			
S	i	p	h	o	n		S	w	i	t	c	h							
S	v	9	9	9	/	C	U	M	9	9	9	/	R	9	9	9	9	,	5
Press [◀] & [▶] to browse through the last ten faults.																			
Press [MENU] or [ENTER] to exit. The unit will return to the operating screen.																			
The fault menu shows the last ten faults. For each fault the display flashes between the two screens shown above. The top line of the top screen shows the fault number and the bottom line of the top screen shows the date, day and time the fault occurred.																			
On the top line of the bottom screen the fault type is displayed. The bottom line shows the following:																			
SV: The total amount of this fault that has occurred after the last time that the service history was erased (after service was done).																			
CUM: The total amount of this fault. The total amount cannot be erased after service; this shows the fault history of the boiler (electronics) since the start of operation.																			
R: Shows the elapsed time in hrs. between the moment the fault occurred and the moment it was reset.																			

11.18 SETTING THE MAINTENANCE PERIOD REMINDER

The following graphs describe how to check and program the maintenance settings. The standard factory setting for this function is "OFF".

IMPORTANT: It is the law within the UK that all gas appliances are serviced at least every 12 months by a competent engineer, the date function below should not be set for more than 12 months.

11.19 MAINTENANCE SETTINGS

The unit can be programmed in such a way that an automatic maintenance message is displayed.

There are three options that can be selected. A maintenance message appears after:

- * A programmed date is reached.
- * An amount of burning hours is reached.
- * An amount of ignition cycles is reached.

One single option can be activated or all three options.

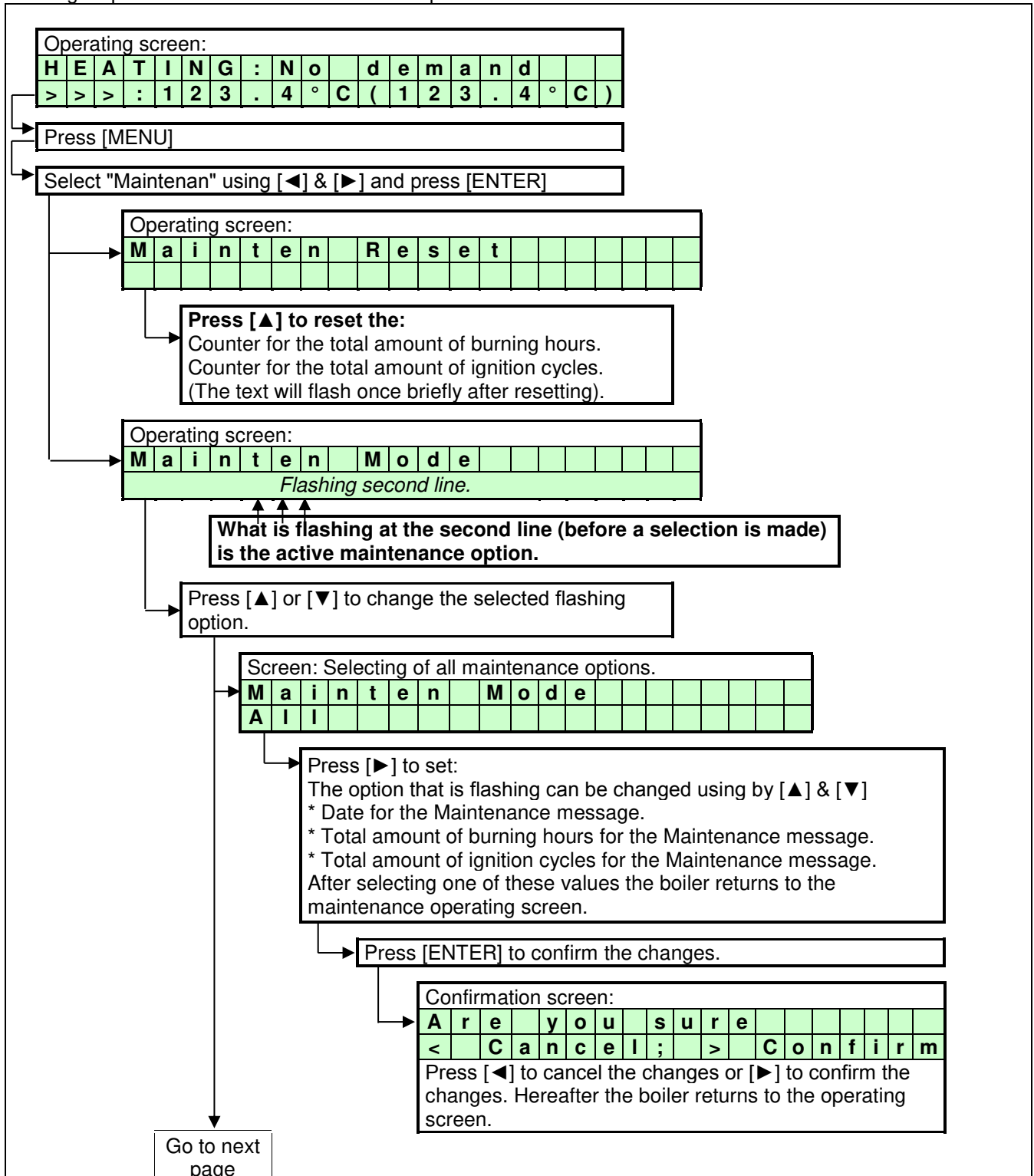

From previous page

Screen: Selecting message at certain date.
M a i n t e n M o d e
D a t e

Press [▶] to set:
The date for the maintenance message.

Press [◀] to:
Return to maintenance mode selection.

Press [▶] to browse through the values that can be set
at the bottom line.
The flashing value can be changed with [▲] & [▼]

Press [ENTER] to confirm the changes.

Confirmation screen:
A r e y o u s u r e
< C a n c e l ; > C o n f i r m
Press [◀] to cancel the changes or [▶] to confirm the
changes. Hereafter the boiler returns to the operating
screen.

Screen: Message after total amount of ignition cycles.
M a i n t e n M o d e
I g n i t i o n c y c l e s

Press [▶] to set:
The total amount of ignition cycles for the Maintenance message.

Press [◀] to:
Return to maintenance mode selection.

The flashing value can be changed with [▲] & [▼]

Press [ENTER] to confirm the changes.

Confirmation screen:
A r e y o u s u r e
< C a n c e l ; > C o n f i r m
Press [◀] to cancel the changes or [▶] to confirm the
changes. Hereafter the boiler returns to the operating
screen.

Go to
next page

From previous page

Screen: Message after total amount of burning hours.

M	a	i	n	t	e	n	M	o	d	e										
B	u	r	n	i	n	g	h	o	u	r	s									

Press [▶] to set:
The total amount of burning hours for the Maintenance message.

Press [◀] to:
Return to maintenance mode selection.

The flashing value can be changed with [▲] & [▼]

Press [ENTER] to confirm the changes.

Confirmation screen:

A	r	e	y	o	u	s	u	r	e										
<	C	a	n	c	e	l	;	>	C	o	n	f	i	r	m				

Press [◀] to cancel the changes or [▶] to confirm the changes. Hereafter the boiler returns to the operating screen.

Screen: No maintenance message will be displayed.

M	a	i	n	t	e	n	M	o	d	e									
M	a	i	n	t	e	n	O	f	f										

Press [ENTER] to confirm the changes.

Confirmation screen:

A	r	e	y	o	u	s	u	r	e										
<	C	a	n	c	e	l	;	>	C	o	n	f	i	r	m				

Press [◀] to cancel the changes or [▶] to confirm the changes. Hereafter the boiler returns to the operating screen.

Note: The [MENU] button will return the display to the operating screen.



It is and remains the responsibility of the end user to have the unit maintained every twelve months. Any warranty claims are dependent on proof the appliance has been serviced correctly.

11.20 SETTING THE USER LOCK

The following graphs describe how to activate the user lock of the display. The standard factory setting for this function is "OFF".

<p>The "USER LOCK" menu. In this menu the boiler can be locked for (end-) users. 0 = UNLOCKED 1 = LOCKED</p>																																																						
<p>When the boiler is unlocked, the user can enter the MENU by pressing the menu button and all screens will show up.</p>																																																						
<p>When the boiler is locked, the user has to push the [MENU] button together with the [▼] button for 5 s. to access all menu screens.</p>																																																						
<p>This function is to prevent accidental changes!</p>																																																						
<p>NOTICE: The PARAMETER screen always accessible.</p>																																																						
<p>Operating screen:</p> <table border="1"> <tr> <td>H</td><td>E</td><td>A</td><td>T</td><td>I</td><td>N</td><td>G</td><td>:</td><td>N</td><td>o</td><td>d</td><td>e</td><td>m</td><td>a</td><td>n</td><td>d</td><td></td><td></td><td></td><td></td><td></td><td></td><td></td><td></td><td></td><td></td> </tr> <tr> <td>></td><td>></td><td>></td><td>:</td><td>1</td><td>2</td><td>3</td><td>.</td><td>4</td><td>°</td><td>C</td><td>(</td><td>1</td><td>2</td><td>3</td><td>.</td><td>4</td><td>°</td><td>C</td><td>)</td><td></td><td></td><td></td><td></td><td></td><td></td><td></td> </tr> </table>	H	E	A	T	I	N	G	:	N	o	d	e	m	a	n	d											>	>	>	:	1	2	3	.	4	°	C	(1	2	3	.	4	°	C)								
H	E	A	T	I	N	G	:	N	o	d	e	m	a	n	d																																							
>	>	>	:	1	2	3	.	4	°	C	(1	2	3	.	4	°	C)																																			
<p>Press [MENU]</p>																																																						
<p>Select "User lock" using [◀] & [▶] and press [ENTER]</p>																																																						
<p>User lock screen:</p> <table border="1"> <tr> <td>S</td><td>e</td><td>t</td><td></td><td>U</td><td>s</td><td>e</td><td>r</td><td>l</td><td>o</td><td>c</td><td>k</td><td>=</td><td>0</td><td></td><td></td><td></td><td></td><td></td><td></td><td></td><td></td><td></td><td></td><td></td><td></td><td></td> </tr> <tr> <td></td><td></td><td></td><td></td><td>0</td><td></td><td></td><td></td><td></td><td></td><td></td><td></td><td></td><td></td><td></td><td></td><td></td><td></td><td></td><td></td><td></td><td></td><td></td><td></td><td></td><td></td><td></td> </tr> </table>	S	e	t		U	s	e	r	l	o	c	k	=	0																		0																						
S	e	t		U	s	e	r	l	o	c	k	=	0																																									
				0																																																		
<p>The "0" is now flashing/selected and can be changed. Use [▲] & [▼] to change the value. 0 = User lock function OFF 1 = User lock function ON</p>																																																						
<p>Press [ENTER] for the confirmation screen after the selection has been made.</p>																																																						
<p>Confirmation screen:</p> <table border="1"> <tr> <td>A</td><td>r</td><td>e</td><td></td><td>y</td><td>o</td><td>u</td><td></td><td>s</td><td>u</td><td>r</td><td>e</td><td></td><td></td><td></td><td></td><td></td><td></td><td></td><td></td><td></td><td></td><td></td><td></td><td></td><td></td><td></td> </tr> <tr> <td><</td><td>C</td><td>a</td><td>n</td><td>c</td><td>e</td><td>l</td><td>;</td><td></td><td>></td><td>C</td><td>o</td><td>n</td><td>f</td><td>i</td><td>r</td><td>m</td><td></td><td></td><td></td><td></td><td></td><td></td><td></td><td></td><td></td><td></td> </tr> </table>	A	r	e		y	o	u		s	u	r	e																<	C	a	n	c	e	l	;		>	C	o	n	f	i	r	m										
A	r	e		y	o	u		s	u	r	e																																											
<	C	a	n	c	e	l	;		>	C	o	n	f	i	r	m																																						
<p>Press [◀] to cancel the changes (the unit will reset and the display returns to the operating screen).</p>																																																						
<p>Press [▶] to confirm the changes. The changed value will be flashing for a few seconds. After this, the display returns to the operating screen.</p>																																																						
<p>NOTICE:</p>																																																						
<p>Using the [MENU] button during the User lock display, will reset the boiler and the boiler will return to the operating screen. Changes will be neglected in this case.</p>																																																						

11.21 SETTING THE PARAMETERS AT THE CONTROL PANEL

The functions of the controller are embedded in the electronics by means of parameters. The values and settings hereof can be programmed by a skilled and trained service engineer with the help of a computer (laptop), the correct software and an interface cable. A selection of these parameters can be programmed at the control panel of the unit itself, without the use of a computer.

The following table gives a list of these last mentioned parameters. NOTICE: Only the password for level 1 is issued in this manual. "More advanced" parameters need to be programmed by a skilled and trained service engineer with access to level 2.

When 'Modify = no', the parameter can only be programmed at level 2

PASSWORD:
1342

MENU	PARAMETER	DESCRIPTION	UNITS	TEXT DISPLAY	LEVEL 1 Modify
HEATING A	1 P5BE	Step modulation (1=on 0=off)	-	S t e p m o d u l	no
	2 P5AO	Blocking offset flow temperature control	°C	H E s O f f 1 3	yes
	3 P5AP	Proportional range temperature control	°C	H E s P r b 1 3	no
	4 P5AL	Hysteresis CH Flow temperature control	°C	H E s c D i f 1 3	yes
	5 P2IC	Integration time temperature control	s	H E s I n t 1 3	no
	6 P2MI	Blocking offset System CH temperature control	°C	H E c O f f 1 3	yes
	7 P2MJ	Proportional range System CH temperature control	°C	H E c P r b 3	no
	8 P2MK	Integration time CH temperature control	s	H E c I n t 3	no
	9 P5AB	Timer Contact (1=on)	-	T i m e r C o n t	yes
DHW B	1 P4AB	DHW Pump Config 0=Pump 1=TWV	-	D H i p m p / t w v	yes
	2 P5CB	Flow temperature DHW tank low	°C	D H i f l o w L O	yes
	3 P5CK	Flow temperature DHW tank hi	°C	D H i f l o w H I	yes
	4 P5CL	Low Flow temperature time DHW	min	D H i L O t i m e	yes
	5 P5CD	Legionella temperature	°C	L e g i o t e m p	no
	6 P5CI	Legionella hyst DHW tank temperature	°C	L e g i o h y s t	no
	7 P5CJ	Legionella hold time (0=off)	min	L e g i o h o l d	no
	8 P2KI	CH interrupt by Legionella (0=yes)(1=no)	-	L e g i o i n t r	no
	9 P2LC	Regulation temperature offset DHWd	°C	D H d s c O f f 2	yes
	A P2MN	Proportional range DHWd modulation	°C	D H d s c P r b 2 3	no
	B P2LD	Regulation temperature hysteresis DHWd	°C	D H d s c D i f 2	yes
	C P2MO	integration time DHWd modulation	s	D H d s c I n t 2 3	no
	D P2ML	Sys temp blocking offset DHW tank	°C	D H d s c O f f 3	yes
	E P2MM	Sys temp blocking hysteresis DHW tank	°C	D H d s c D i f 3	yes
F P5CA	Hysteresis DHW tank temperature	°C	D H i s c D i f 4	yes	
G P2KH	Gradient heat demand detect DHW tank temperature	°C	D H i d e t g r a d	yes	
CASCADE C	1 P2MA	Max number extra boilers	-	M a x C a s c U n t	no
	2 P5DA	Bus address boiler	-	B u s a d r e s s	no
	3 P5DC	Dhw on entire cascade(0) only master(1)	-	D H i c a s / m a s	no
	4 P5DE	Extra Boiler output enable(1)	-	E x t r a u n i t	yes
	5 P5DF	Cascade detection (0=standalone 1=Leader)	-	C a s S i / M a	no
	6 P5BL	Power off total cascade (1)	-	P w r O f f T o C a	no
	7 P5DB	Number of boilers with common flue 0=None	-	C o m F l u N u m	no
GENERAL D	1 P5BB	Analogue input Config (0=off 1=temp 2=power)	-	A n I n p C o n	yes
	2 P5AI	Minimum Temperature 0-10V input	°C	0 - 1 0 M i n T m p	yes
	3 P5BI	Altitude (in amounts of 96 ft.)	96 ft	A l t * 1 0 0 f t	yes
	4 P2LK	Max cooling time	min	M a x C o o l T i m	yes
	5 P5BJ	Temperature display 1=on	-	T e m p O n D i s p	yes
	6 P4AA	DHW 0=off 1=Indirect 2=Direct	-	D H W 1 = i 2 = d	no
	7 P4AD	pressure 0=off 1=sensor and 2=switch	-	c o n f i g	no
	8 P4BD	Gas type values 0-2	-	g a s t y p e	no
	9 P4BE	Soft start type values 0-2	-	c o n f i g	no
	A P5BN	Pump modes 0-3	-	c o n f i g	no

For extensive explanation see Ch. 12: 'Controlling options and settings', page 86 ff.



IMPORTANT: Do not change the parameters P2LC, P2LD, P2ML, P2MM and P5BI; they are present in the controller for different purposes than CH control. Changing these parameters may affect boiler operation negatively.

Parameter screens + concise explanation see next pages →

Operating screen:
H E A T I N G : N o d e m a n d
> > > : 1 2 3 . 4 ° C (1 2 3 . 4 ° C)

Press [MENU]

Select "Parameter" using [◀] & [▶] and press [ENTER]

Parameter menu:
I n s t a l l e r c o d e
0 0 0 0

Enter the 4-digit code with the [◀] & [▶] and the [▲] & [▼] buttons and select [ENTER]
 The code will flash a few seconds and when entered correctly, the following parameters will be displayed.

NOTICE: These codes are user based and give access to a selected amount of parameters, which can be changed (Installer level 1/2).

Menu A: Heating
A 1 S t e p m o d u l 1

Function to activate the step modulation:
 0 = Off
 1 = On

Menu A: Heating
A 2 H E s o f f 1 3
4 ° C

CH supply temperature setting. This parameter is the offset of the programmed CH temperature.

Menu A: Heating
A 3 H E s P r b 1 3
2 5 ° C

Select the CH supply temperature control. This parameter is the proportional range of the selected CH supply temperature.

Menu A: Heating
A 4 H E s c D i f 1 3
1 0 ° C

Select the CH supply temperature control. This parameter is the hysteresis of the selected CH supply temperature.

Menu A: Heating
A 5 H E s I n t 1 3
6 0 S e c

Select the CH supply temperature control. This parameter is the integration time of the selected CH supply temperature.

Menu A: Heating
A 6 H E c O f f 3
4 ° C

Select the cascaded boilers supply temperature control. This parameter is the offset of the selected CH supply temperature of EACH boiler of the total cascade.

The screen texts on these pages are standard within the software and apply to CPM Boiler and also EF direct gas fired water heaters. Not all Parameters will be applicable depending upon appliance type.

Menu A: Heating																		
A	7					H	E			c	P	r	b	3				
										2	5		°	C				
Select the cascaded boilers supply temperature control. This parameter is the proportional range of the selected CH supply temperature of EACH boiler of the total cascade and of the external (cascade) sensor.																		

The screen texts on these pages are standard within the software and apply to CPM Boiler and also EF direct gas fired water heaters. Not all Parameters will be applicable depending upon appliance type.

Menu A: Heating																		
A	8					H	E			c	I	n	t	3				
										8	0		S	e	c			
Select the cascaded boilers supply temperature control. This parameter is the integration time of the selected CH supply temperature of EACH boiler of the total cascade and of the external (cascade) sensor.																		

Menu A: Heating																		
A	9					T	i	m	e	r	C	o	n	t				
										0								
Function to activate "external time controller": 0 = Off 1 = On Connect to 13-14. Contact closed = daytime setting, Contact open = night-time setting.																		

Menu B: Hot water																		
B	1					D	H	i	p	m	p	/	t	w	v			
										1								
Hot water function of the boiler by: 0 = pump 1 = 3-way valve																		

Menu B: Hot water																		
B	2					D	H	i	f	l	o	w	L	O				
										2	5		°	C				
Hot water function of the boiler. This parameter is the CH supply temperature LOW level with an indirect hot water demand.																		

Menu B: Hot water																		
B	3					D	H	i	f	l	o	w	H	I				
										8	5		°	C				
Hot water function of the boiler. This parameter is the CH supply temperature HIGH level with an indirect hot water demand.																		

Menu B: Hot water																		
B	4					D	H	i	L	O	t	i	m	e				
										1		M	i	n				
Hot water function of the boiler. This parameter is the selectable time period after which the boiler switches from LOW to HIGH set point with an indirect hot water demand.																		

Menu B: Hot water												
B	5			L	e	g	i	o	t	e	m	p
								8	5	°	C	
Pasteurisation function of the boiler. This parameter is the selected hot water temperature during the pasteurisation function of the boiler.												

Menu B: Hot water												
B	6			L	e	g	i	o	h	y	s	t
								2		°	C	
Pasteurisation function of the boiler. This parameter is the selected hysteresis during the pasteurisation function of the boiler.												

Menu B: Hot water												
B	7			L	e	g	i	o	h	o	l	d
								2		M	i	n
Pasteurisation function of the boiler. This parameter is the selected time period for the pasteurisation function of the boiler.												

Menu B: Hot water												
B	8			L	e	g	i	o	i	n	t	r
								0				
Pasteurisation function of the boiler. This parameter controls if the CH demand can be interrupted by the pasteurisation function of the boiler. 0 = Yes 1 = No												

Menu B: Hot water												
B	9			D	H	d	s	c	O	f	f	2
								4		°	C	
Function for the direct hot water boiler. This parameter is de off set of the selected HW temperature of the boiler.												

Menu B: Hot water													
B	A			D	H	d	s	c	P	r	b	2	3
								2	0		°	C	
Function for the direct hot water boiler. This parameter is the proportional range of the selected HW temperature of the boiler.													

Menu B: Hot water													
B	B			D	H	d	s	c	D	i	f	2	
								1	0		°	C	
Function for the direct hot water boiler. This parameter is the hysteresis of the selected HW temperature of the boiler.													

The screen texts on these pages are standard within the software and apply to CPM Boiler and also EF direct gas fired water heaters. Not all Parameters will be applicable depending upon appliance type.

Menu B: Hot water																							
B	C					D	H	d	s	c	I	n	t	2	3								
														2	0	0	S	e	c				
Function for the direct hot water boiler. This parameter is the integration time of the selected HW temperature of the boiler.																							

The screen texts on these pages are standard within the software and apply to CPM Boiler and also EF direct gas fired water heaters. Not all Parameters will be applicable depending upon appliance type.

Menu B: Hot water																							
B	D					D	H	d	s	c	O	f	f	3									
														4		°	C						
Function for the cascaded direct hot water boilers. This parameter is the offset of the selected HW temperature of the cascaded boilers.																							

Menu B: Hot water																							
B	E					D	H	d	s	c	D	i	f	3									
														8		°	C						
Function for the cascaded direct hot water boilers. This parameter is the hysteresis of the selected HW temperature of the cascaded boilers.																							

Menu B: Hot water																							
B	F					D	H	i	s	c	D	i	f	4									
														5		°	C						
Function for the indirect hot water supply of the boiler (tank). This parameter is the hysteresis of the selected HW temperature of the Indirect DHW Cylinder.																							

Menu B: Hot water																							
B	G					D	H	i	d	e	t	g	r	a	d								
														3		°	C						
Function for the indirect hot water supply of the boiler (tank). This parameter detects an (an accelerated) hot water demand, when a larger (water) amount is being used.																							

Menu C: Cascade																							
C	1					M	a	x	C	a	s	c	U	n	t								
														1	1								
Function for the cascading of the boiler(s). This parameter sets the total amount of cascaded boilers. (Max. 12 boilers).																							

Menu C: Cascade																							
C	2					B	u	s		a	d	d	r	e	s	s							
														0									
Function for the cascading of the boiler(s). This parameter determines the address of the boiler for the total cascading control. Master = 0, Slave 1 = 1 etc.																							

Menu C: Cascade																							
C	3					D	H	i	c	a	s	/	m	a	s								
														0									
Function for the cascading of the boiler(s). This parameter determines if only the Master boiler or all boilers of the cascade are used for indirect hot water. 0 = All 1 = Master																							

Menu C: Cascade															
C	4					E	x	t	r	a		u	n	i	t
												0			
Function for the cascading of the boiler(s). This parameter is activated when an external (extra) boiler is connected to the Master boiler. Connect to the Master connections 21-22.															

The screen texts on these pages are standard within the software and apply to CPM Boiler and also EF direct gas fired water heaters. Not all Parameters will be applicable depending upon appliance type.

Menu C: Cascade															
C	5					C	a	s		S	i	/	M	a	
												0			
Function for the cascading of the boiler(s). This parameter sets the function of the boiler at a cascade alignment 0 = Single / Slave unit 1 = Master unit															

Menu C: Cascade															
C	6					P	w	r	O	f	T	o	C	a	
												0			
Function for the cascading of the boiler(s). This parameter determines the function of the Slave boilers when the Master boiler is switched off. 0 = Slave boiler(s) continue operation 1 = Slave boiler(s) switch off															

Menu C: Cascade															
C	7					C	o	m	F	l	u	N	u	m	
												0			
Function for the cascading of the boiler(s). This parameter determines the number of cascaded boilers that are implemented with a common flue system.															

Menu D: General															
D	1					0	-	1	0	V	c	o	n	t	r
												0			
Function for the external control of the boiler by using a 0-10 Volt signal (Connections 15-16). 0 = No external control 1 = Control based on temperature setting 2 = Control based on power setting															

Menu D: General															
D	2					0	-	1	0	M	i	n	T	m	p
										2	0	°	C		
Function for the external control of the boiler by using a 0-10 Volt signal (Connections 15-16). Control based on temperature (setting 1). The minimum (desired) CH water temperature when supplying a 1,4 Volt signal.															

Menu D: General															
D	3					A	i	t		*		1	0	0	f
											0				
Function for setting the location height (above sea level) of the boiler. NOTICE: dimensions in English feet. One unit = 96 ft. Use this function only in consultation with the supplier / manufacturer.															

Menu D: General												
D	4											
Function for setting the maximum overrun time of the fan (maximum 10 minutes). 0 = Switch off												

The screen texts on these pages are standard within the software and apply to CPM Boiler and also EF direct gas fired water heaters. Not all Parameters will be applicable depending upon appliance type.

Menu D: General												
D	5											
Function to show the (measured) temperature of the boiler at the display.												

Menu D: General												
D	6											
Function to set up the CH and HW boiler options. 0 = CH only (direct) 1 = CH/HW function (indirect) 2 = HW only (direct)												

Menu D: General												
D	7											
Function for the setting of the water pressure. Up to 4 bar a sensor is used, up to 6 bar a switch. 0 = off 1 = sensor 2 = switch												

Menu D: General												
D	8											
Function to select the gas type* 0 = G20, G25 and for Poland G27, G2.350 1 = G31 2 = B/P *According to EN437												

Menu D: General												
D	9											
Function for setting the 'soft start' option 0 = normal start-up 1 = reduced fan ramp-up speed (I) 2 = reduced fan ramp-up speed (II)												

Menu D: General												
D	A											
Function: Pump mode 0 = normal 1 = relay 1, connector 19 and 20 (lock-out) 2 = relay 2, connector 21 and 22 (burner burning) 3 = relay 3, connector 23 and 24 (heat demand)												

11.22 FAULT CODES DISPLAY

The following graphs describe the lock out codes of the boiler. A lock out code can only be removed by a manual resetting of the boiler.



Before resetting the boiler always check the boiler, central heating system and all components corresponding to the related lock out description. Never just reset the boiler, before analysing the possible cause of failure.

11.22.1 Lock-out codes

Having a lockout means that the boiler needs a manual reset to start operating again. When the boiler is in lockout the backlight of the display is flashing on and off.

Explanation >

9	9	9	,	5	:	h	r	s
---	---	---	---	---	---	---	---	---

 = time elapsed after fault & message.

Explanation >

P	u	m	p	1	o	n
---	---	---	---	---	---	---

 = status of the pump during fault.

Display message	F l o w s e n s o r e r r o r
F0	p u m p o n 9 9 9 , 5 h r s
Reason	Flow sensor not detected by the boiler caused by faulty connection/sensor.

Display message	F l o w h i g h T e m p
F1	p u m p o n 9 9 9 , 5 h r s
Reason	Flow temperature exceeds the limit which has been set in the parameters.

Display message	R e t u r n h i g h T e m p
F1	p u m p o n 9 9 9 , 5 h r s
Reason	The maximum return temperature as set in the parameters is exceeded.

Display message	R e t u r n s e n s o r e r r o r
F3	p u m p o n 9 9 9 , 5 h r s
Reason	Return sensor not detected by the boiler caused by faulty connection/sensor.

Display message	F l u e s e n s o r e r r o r
F6	p u m p o n 9 9 9 , 5 h r s
Reason	Flue gas sensor not detected by the boiler caused by faulty connection/sensor.

Display message	F l u e t e m p t o o h i g h
F7	p u m p o n 9 9 9 , 5 h r s
Reason	Flue gas temperature exceeds the limit which has been set in the parameters more than 3 times within the set timeframe.

Display message	F a i l e d b u r n e r s t a r t
F8	p u m p o n 9 9 9 , 5 h r s
Reason	Boiler does not start after 4 start attempts.

Display message	F	l	a	m	e	l	o	s	t								
F9	p	u	m	p	o	n				9	9	9	,	5	h	r	s

Reason Flame detected during normal operation, but was lost while running.

Display message	F	a	i	s	e	f	l	a	m	e	s	i	g	n	a	l		
F10	p	u	m	p	o	n					9	9	9	,	5	h	r	s

Reason Flame signal is detected when no heat demand is present.

Display message	F	a	n	s	p	e	e	d	i	n	c	o	r	r	e	c	t	
F11	p	u	m	p	o	n					9	9	9	,	5	h	r	s

Reason Incorrect fan speed detected.

Display message	p	r	o	g	r	a	m	m	i	n	g	e	n	d				
F12	p	u	m	p	o	n					9	9	9	,	5	h	r	s

Reason Software parameters have been programmed successfully.

Display message	P	a	r	a	m	/	H	a	r	d	w	f	a	u	l	t		
F13	p	u	m	p	o	n					9	9	9	,	5	h	r	s

Reason Fault during programming of the boiler software parameters.

Display message	C	l	i	x	o	n	F	a	u	l	t							
F15	p	u	m	p	o	n					9	9	9	,	5	h	r	s

Reason Heat exchanger fuse or burner door clixon exceeded maximum allowed value.

Display message	F	l	o	w	R	e	t	u	r	n	d	t	f	a	u	l	t	
F16	p	u	m	p	o	n					9	9	9	,	5	h	r	s

Reason Temperature difference between flow and return exceeds limitation value, or 'dT block or delta direct block' has occurred three times.

Display message	W	a	t	e	r	h	i	g	h	l	i	m	i	t				
F17	p	u	m	p	o	n					9	9	9	,	5	h	r	s

Reason High temperature limit thermostat has exceeded its value

Display message	S	i	p	h	o	n	s	w	i	t	c	h						
F19	p	u	m	p	o	n					9	9	9	,	5	h	r	s

Reason The pressure switch detects a high pressure in the flue/condensate drain system.

11.22.2 Blocking codes

Blocking codes signify that a situation is present under which the boiler is not safe to operate but once the situation clears, operation can safely continue. When a blocking of the boiler is active, the display is constantly illuminated.

When a blocking occurs, the display will show a description of the condition in the top line of the display; the bottom line of the display will show the time that has elapsed since the blocking occurred.

Display message	A	n	t	i	c	y	c	l	e	t	i	m	e				
											9	9	9	,	5	h	r

Reason The controller received a new heat demand too quick after the last ended demand.

Display message	F	l	u	e	t	e	m	p									
											9	9	9	,	5	h	r

Reason Flue gas temperature has exceeded the limit, as set in the parameters.

Display message	F	l	o	w	t	e	m	p									
											9	9	9	,	5	h	r

Reason Flow temperature has exceeded the blocking temperature, as set in the parameters but the flow temperature has not exceeded the lock-out value.

Display message	R	e	t	u	r	n	t	e	m	p							
											9	9	9	,	5	h	r

Reason Return temperature has exceeded the blocking temperature, which is set in the parameters, but the return temperature has not exceeded the lock-out value.

Display message	T	2	-	T	1												
											9	9	9	,	5	h	r

Reason Temperature difference T2-T1 has exceeded the blocking value as set in the parameters.

Display message	D	e	a	i	r	a	t	i	o	n							
											9	9	9	,	5	h	r

Reason The boiler starts its de-aeration function and after will return to normal operation. This function can be activated by parameter P4AJ.

Display message	W	a	t	e	r	p	r	e	s	s	u	r	e	f	a	u	l	t
											9	9	9	,	5	h	r	s

Reason Water pressure is too low or too high.

Display message	O	u	t	d	o	o	r	s	e	n	s	o	r	f	a	i	l
											9	9	9	,	5	h	r

Reason Outdoor temperature has exceeded the blocking temperature which is set in the parameters.

Display message	d	T	B	l	o	c	k										
											9	9	9	,	5	h	r

Reason Temperature difference between flow and return exceeds the blocking value but not the lock out value.

Display message	C	a	s	c	a	d	e	B	l	o	c	k					
											9	9	9	,	5	h	r

Reason Connection failure with one of the Cascade boilers

Display message	L	i	n	e	f	a	u	l	t								
											9	9	9	,	5	h	r

Reason Incorrect/faulty power supply

Display message	G	e	n	B	l	o	c	k									
											9	9	9	,	5	h	r

Reason The general blocking circuit is activated during operation = contact 7-8

11.23 MESSAGES

The following graphs describe the messages at the boiler display. Depending on the selected and activated options for the boiler, it is possible that some messages will show up at the display of the boiler. For example a maintenance message after a certain programmed date has been reached. The boiler will operate independently of these messages.

11.23.1 Maintenance Attention Function

The display shows alternating the base screen and this message, while the backlight is flashing.

The boiler is operating, but will count the hours since the reminder started.

A parameter must be changed, after service, to remove this message.

Display message	N	e	e	d	s	M	a	i	n	t	e	n	a	n			0	.	0
	I	g	n	i	t	i	o	n	c	y	c	l	e	s			h	r	s

Reason Maintenance option of total amount of ignition cycles has been reached.

Display message	N	e	e	d	s	M	a	i	n	t	e	n	a	n			0	.	0
	D	a	t	e												h	r	s	

Reason Maintenance option of the date has been reached.

Display message	N	e	e	d	s	M	a	i	n	t	e	n	a	n			0	.	0
	B	u	r	n	i	n	g	h	o	u	r	s				h	r	s	

Reason Maintenance option of total amount of burning hours has been reached.

Display message	N	e	e	d	s	M	a	i	n	t	e	n	a	n			0	.	0
	A	i	l													h	r	s	

Reason One of the above mentioned maintenance options has been reached.

12 CONTROL OPTIONS AND SETTINGS

12.1 GENERAL

The following paragraphs describe some general functions of the boiler and their possible use.

12.1.1 Extra boiler control

When all units (cascaded) are firing at their maximum it is possible to start an extra “external” heating source. This unit can be connected to the “Burner Burning” contacts (connection 21-22).

P5DE Extra Boiler output enable (1) (display C4)

When this parameter is set 1, the contact “Burner Burning” will close, but only when all units are firing at a certain (programmable) input percentage. The standard factory setting for this function is “OFF”.

12.1.2 Max cooling time

The fan will cool down the heat exchanger according to the temperature settings (parameters) of the software. With this cooling parameter the maximum run time of the fan can be programmed.

P2LK Max cooling time (display D4)

This function is not used for central heating boilers.

12.1.3 Temperature display on/off

Selection for showing the measured temperatures at the operation display of the boiler.

P5BJ Temperature display 1=on (display D5)

The measured temperature at the operation display.

0 = not visible

1 = visible

12.1.4 Water pressure

P4AD pressure 0=off, 1=sensor, 2=switch.

When the water pressure exceeds 4 bar a pressure switch must be used instead of the sensor (suitable for up to 4 bar). With the external switch, the pressure can go up to 6 bar.

If required to operate at more than 4 bar remove the pressure sensor and replace it with the pressure switch. Now set the parameter at the control panel by changing “D7 config” from 1 into 2.

12.1.5 Gas type selection

Settings for gas types: natural gas, propane or butane-propane mixture (B/P).

P4 BD Gas type (0=standard, 1=propane, 2=B/P) (display D8)

This parameter is set 0 for the common used gas types such as natural gas G20 or G25.

By setting this parameter 1 for propane, fan speed is reduced.

Set this parameter 2 for B/P.

0 = standard gas (e.g.: natural gas), Lw, Ls (Lw and Ls only for Poland)

1 = propane

2 = B/P

On each setting the relevant Soft start settings are automatically adjusted, depending on its main setting P4BE, see next section § 12.1.6.



In case of gas conversion, paste the corresponding sticker at the appropriate position in the water heater and mark the square for the used gas type. Also mark the square, indicating that the correct value has been set for parameter P4BD.

(In the example on the right, 'propane' and 'P4BD = 1' have been marked).

G31 P	PROPANE PROPAN PROPANO PROPAAN	<input type="checkbox"/>	P4BD = 1	<input type="checkbox"/>
G30/G31 B/P	BUTANE/PROPANE BUTAN/PROPAN BUTANO/PROPANO BUTAAN/PROPAAN	<input type="checkbox"/>	P4BD = 2	<input type="checkbox"/>

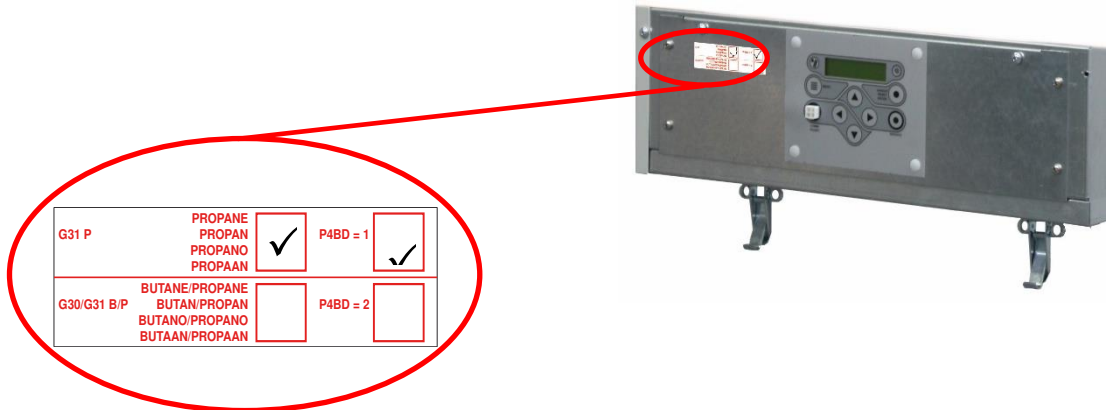

12.1.6 Soft start option

Start parameters can be modified to achieve better start behaviour, in case of noise or other difficulties. This is done by reducing the fan ramp-up speed. Two reduced settings are available (I and II).

P4 BE Soft start (0=normal, 1=reduced fan ramp-up speed (I), 2=reduced fan speed ramp-up (II)) (display D9).

- 0 = normal start-up
- 1 = reduced fan ramp-up speed (I)
- 2 = reduced fan ramp-up speed (II)

12.1.7 Pump mode (EC technology)

When using a pump with Electronic Commutation technology and start-stop function, with a separate control connection, this parameter determines the relay for switching the pump on and off.

P5 BN Pump mode (0=modulating, 1=relay1, 2= relay2, 3= relay3) (display DA)



Do not use the 230 Vac relay for the main power supply of the pump, but directly connect the pump to an external power supply.

A modulating pump with PWM control: the power supply is directly connected to the mains, the PWM connection is connected to CN10, contacts 9 and 18.

Pumps with an on/off control can be switched by one of the relay connections "lock-out", "burner burning" or "heat demand". Choose a connection which is not yet used.

- 0 = PWM 0-96% modulating pump, connection **CN10**, connectors 9 and 18
- 1 = Start-stop through relay 1, connectors 19 and 20 (lock-out)
- 2 = Start-stop through relay 2, connectors 21 and 22 (burner burning)
- 3 = Start-stop through relay 3, connectors 23 and 24 (heat demand)

12.2 HEATING

The following paragraphs describe the different functions of the boiler and their related “controlling behaviour settings” as a central heating boiler.

12.2.1 Controlling behaviour settings

Factory settings should not be changed without consulting Lochinvar Limited.

P5 AO Blocking offset flow temperature control (display A2)

The amount of degrees the measured temperature exceeds the active flow temperature set point before the heat demand stops. Only active when the unit is controlled by the internal flow sensor (S1) and used for single unit control.

P5 AL Hysteresis CH flow temperature control (display A4)

The amount of degrees that the measured temperature must drop, relative to the active flow temperature set point + Offset (Parameter P5 AO), before the heat demand starts. This function is active when the unit is controlled by the internal flow sensor (S1) and used for single units. When controlling cascaded units with an external flow sensor (S3), this sensor will be used.

P5 AP Proportional range single heating boiler (display A3)

The proportional range for controlling the flow temperature of the boiler. This function is active when the unit is controlled by the internal flow sensor (S1) and used for single units. When controlling cascaded units with an external flow sensor (S3), this sensor will be used.

P2 MI Blocking offset system CH temperature control (display A6)

The amount of degrees the measured temperature exceeds the active flow temperature set point before heat demand stops. Only active when the unit is controlled by an external flow sensor (S3).

The following graph shows the relation between the several parameters.

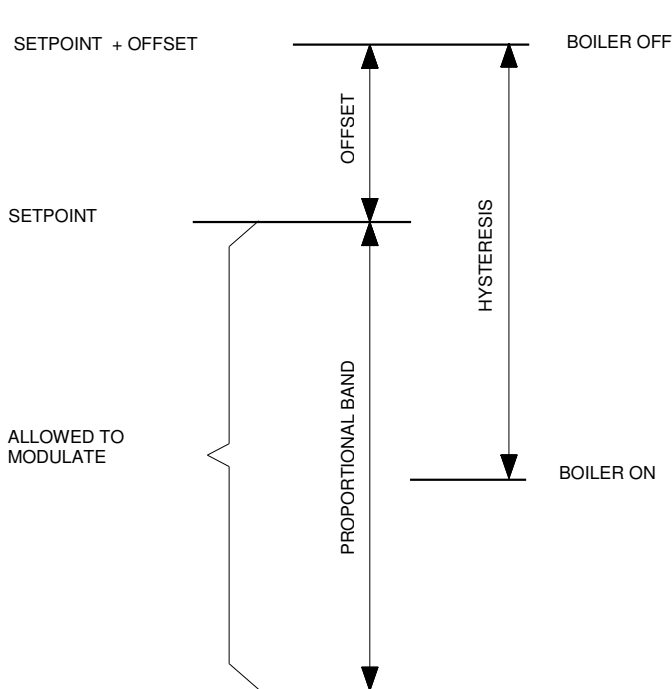

WHEN CONTROLLING ON INTERNAL FLOW SENSOR

Settings:		
P5 AO	Offset	= 5°C
P5 AP	Proportional band	= 15°C
P5 AL	Hysteresis	= 10°C
	Temp. set point	= 50°C

Burner starts at 45°C
 Set point + Offset - Hysteresis = 50+5-10= 45°C

Burner stops at 55°C
 Set point + Offset = 50 + 5 = 55°C

WHEN CONTROLLING ON EXTERNAL FLOW SENSOR

Settings:		
P2 MI	Offset	= 5°C
P5 AP	Proportional band	= 15°C
P5 AL	Hysteresis	= 10°C
	Temp. set point	= 70°C

Burner starts at 65°C
 Set point + Offset - Hysteresis = 70+5-10= 65°C

Burner stops at 75°C
 Set point + Offset = 70 + 5 = 75°C



Curve and values only for illustration purposes, programmed parameter values can deviate

12.2.2 Room thermostat on/off

A room thermostat with a fixed set point and using an ON/OFF control can be connected to the boiler (Connections 13-14). Changing the flow temperature set point and activation of a timer program can be provided by this room thermostat or by programming the boiler settings. See chapter 11.10

12.2.3 Room thermostat OPENTHERM

An RC OpenTherm controller can be connected to the boiler for temperature reading(s) and remote programming (connections 13-14).

12.2.4 Outdoor temperature related flow control

The flow temperature can be calculated by using the measured outdoor temperature for controlling the boiler. See Section 11.14

12.2.5 0-10 Vdc remote flow temperature set point

The flow temperature is controlled by connecting an external 0-10 Vdc signal to the boiler (connections 15-16).

P5 BB Analogue input config (0=off 1=temperature 2=power) (display D1)

This parameter must be set at "1" so the supplied 0-10 Vdc signal will control the temperature set point. Possible settings are:

- 0 = 0-10 V control off
- 1 = 0-10 V temperature set point control active
- 2 = 0-10 V burner input control active

P5 AI Minimum temperature 0-10V input (display D2)

The standard starting temperature of the heat demand, when the minimum voltage signal is sent to the boiler. The factory settings for all heating applications are working fine and it is therefore advised not to change these settings. Always consult the manufacturer for advice if parameter changes are needed.

See also the following graph for the relation between the temperature and the control signal

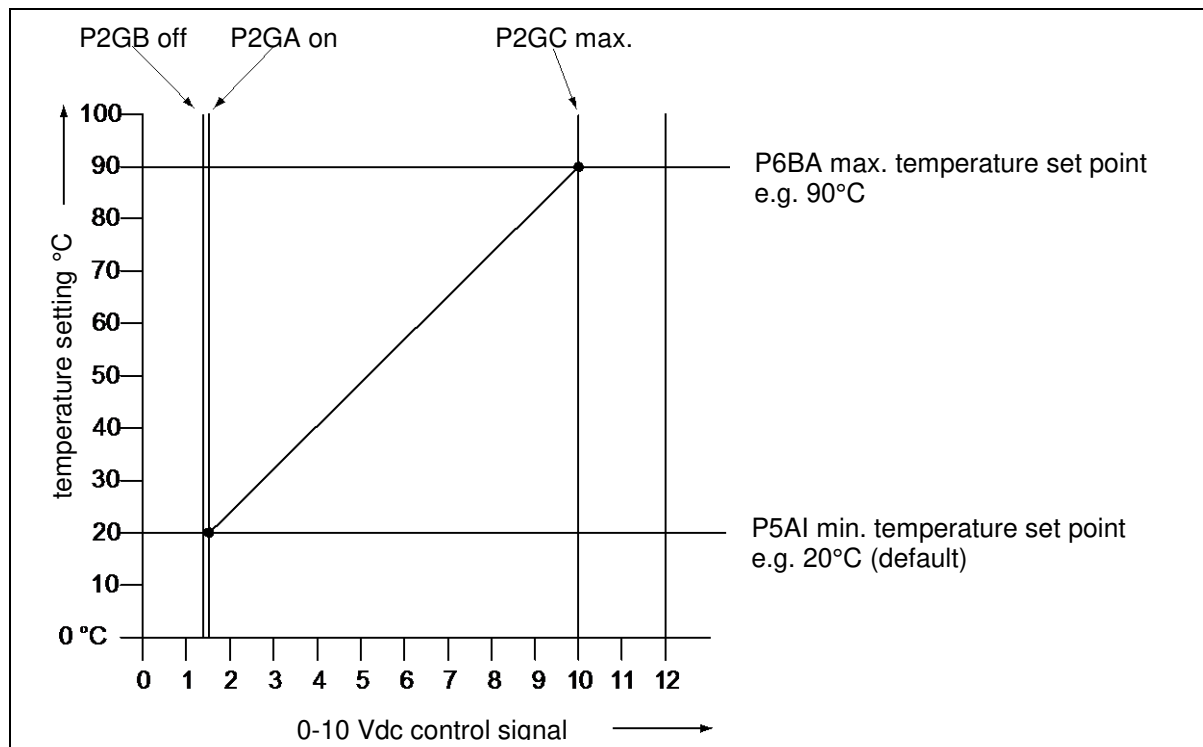

Curve and values only for illustration purposes, programmed parameter values can deviate

12.2.6 0-10 Vdc Remote burner input control

The burner input is controlled by connecting an external 0-10 Vdc signal to the boiler (connections 15-16).

P5 BB Analogue input config (0=off 1=temperature 2=power) (display D1)

This parameter must be set at "2" so the supplied 0-10V dc signal will control the burner input. The standard factory setting is "1", temperature set point control. Possible settings are:

- 0 = 0-10V control off
- 1 = 0-10V temperature set point control active
- 2 = 0-10V burner input control active

See also the following graph for the relation between the burner input and the control signal.

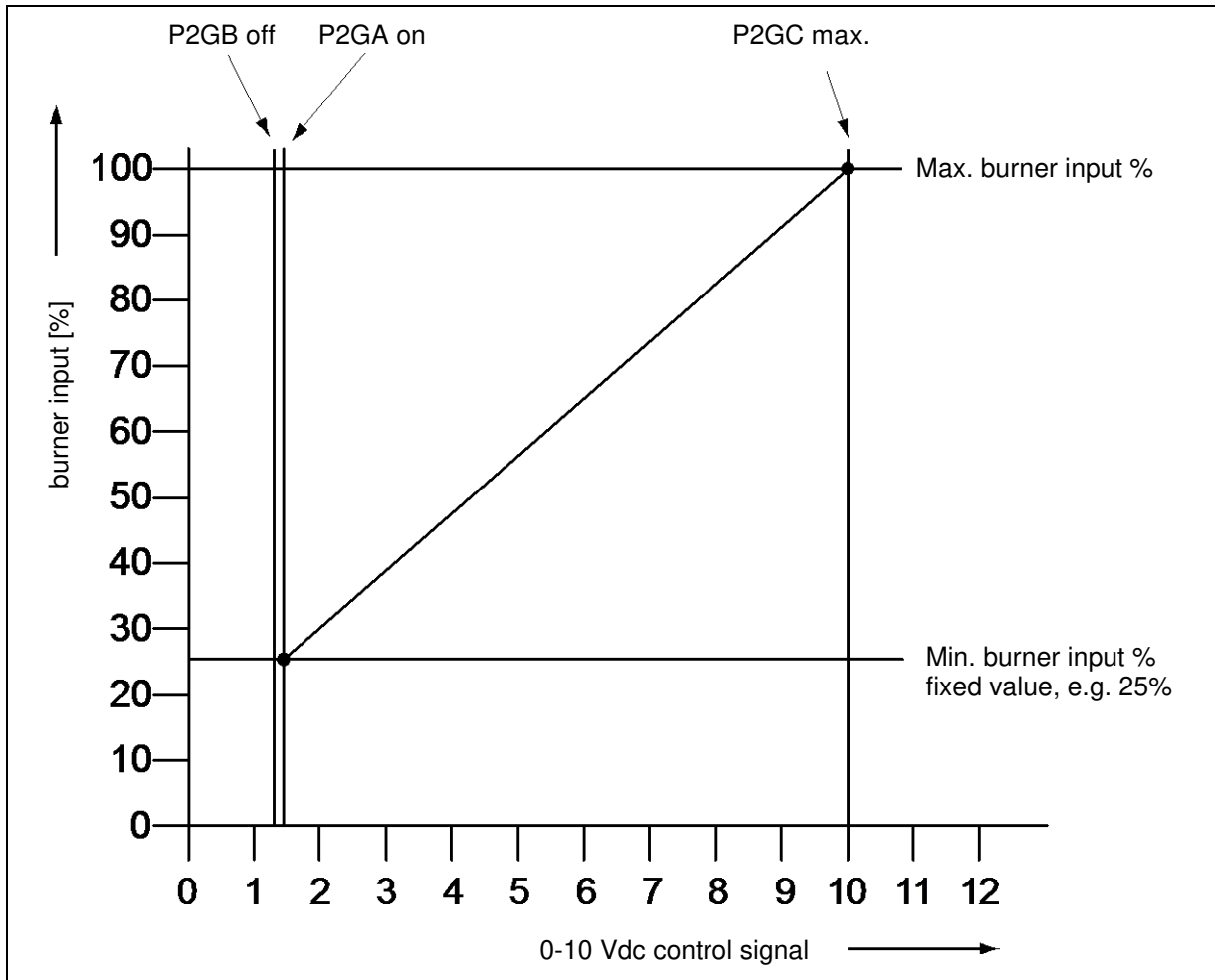

Curve and values only for illustration purposes, programmed parameter values can deviate

12.2.7 Timer contact function

This function can be activated when using an external night setback timer for heating. This timer contact can be connected to the thermostat terminals (connections 13-14).

P5 AB Timer contact (1=on) (display A9)

When this parameter is activated and...

- ...the thermostat terminals are bridged (timer contact closed), the normal daytime temperature is used as set point.
- ...the thermostat terminals are not bridged (timer contact open), the night reduced temperature is used as set point.

12.3 INDIRECT DHW CYLINDER

The following paragraphs describe the functions and setting when the CPM Boiler is used for Indirect DHW production.

12.3.1 Pump and 3-way valve control

When the boiler is used as an indirect boiler for both central heating and hot water function, this hot water function can be activated by using a DHW pump (Indirect DHW Cylinder pump (pump 2)) or a 3-way valve.

P4 AB DHW Pump config 0=Pump 1=TWV (display B1)

With this parameter it is programmed if the flow to the indirect water tank (Indirect DHW Cylinder) is controlled by a pump (0 = pump) or a 3-way valve (1 = TWV).

12.3.2 Cylinder thermostat

An external thermostat can be connected to the boiler (connections 5-6). When there is a hot water demand and the tank thermostat closes, the boiler will start for the hot water demand. The Indirect DHW Cylinder pump will be activated or in case of a 3-way valve, this valve will turn to the position to supply heat to the tank coil(s). In case of a heat demand and hot water demand, the (central) heating pump will switch off until the hot water demand ends.

P4 AB DHW pump Config 0=Pump 1=TWV (display B1)

With this parameter it is programmed if the flow to the indirect water tank (Indirect DHW Cylinder) is controlled by a pump (0 = pump) or a 3-way valve (1 = TWV).

12.3.3 Cylinder sensor

A tank sensor can be connected to the boiler. The tank (hot water) set point and related controlling parameters are set in the boiler controller. A hot water demand is detected by the boiler, when the sensor (water) temperature drops below the set point. The Indirect DHW Cylinder pump will be activated or in case of a 3-way valve, this valve will turn to the position to supply heat to the tank coil(s). In case of a heat and hot water demand at the same time, the heating pump will switch off until the hot water demand is stopped (water temperature is reached).

P5 CA Hysteresis DHW tank temperature (display BF)

The amount of degrees that the hot water temperature in the Indirect DHW Cylinder needs to drop relative to the hot water set point, before a heat demand is sent to the boiler.

12.3.4 Low/high flow temperature to tank coil

This function can only be used for an "indirect" programmed boiler (parameter **P4 AA** = 1).

Normally for a regular Indirect DHW Cylinder a fixed flow temperature of 85°C is supplied to the Indirect DHW Cylinder heat exchanger in case of a heat demand. This hot water flow will indirectly heat up the water in the Indirect DHW Cylinder tank.

The parameters for this function can be configured for both low and high Indirect DHW Cylinder operation.

This function operates as follows:

When there is a heat demand, the boiler supplies water to the heat exchanger of the Indirect DHW Cylinder, according to the flow temperature set in parameter **P5 CB**. When the heat demand remains for the period set in parameter **P5 CL**, the flow temperature set point will change to a higher temperature, which is set in parameter **P5 CK**. This situation continues until the heat demand ends.

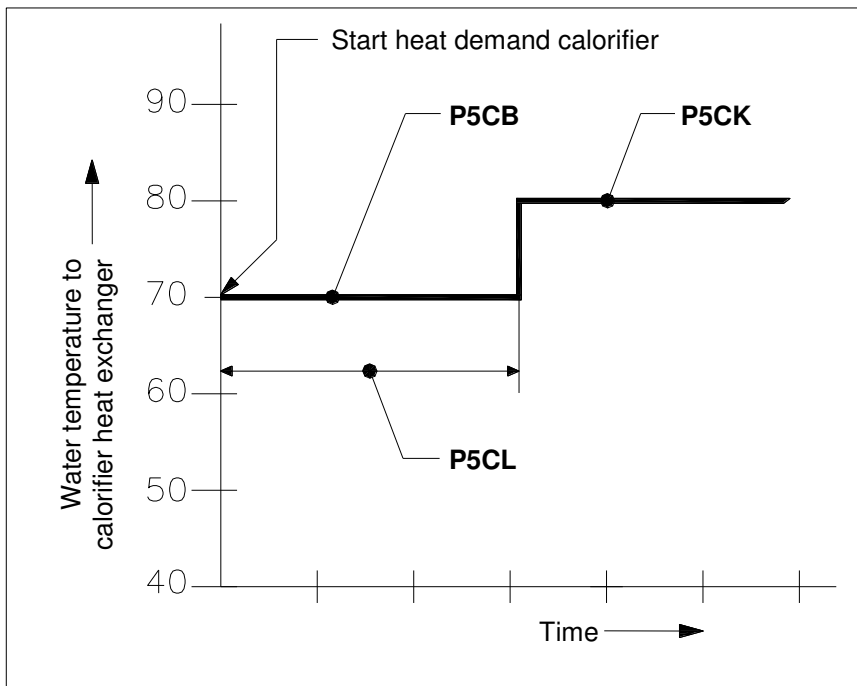

This function allows the boiler to stay in condensing mode for longer if the heating set point is low enough (say for underfloor heating) Eventually the flow temperature set point will change to a higher setting to make sure that the hot water set point is reached.

P5 CB Flow temperature DHW tank low (display B2)

The low level flow temperature to the tank coil(s) in case of an Indirect DHW Cylinder/indirect hot water demand. This “two staged” function is added to keep the boiler in the condensing mode as long as possible.

P5 CK Flow temperature DHW tank high (display B3)

The high level flow temperature to the tank coil(s) in case of an Indirect DHW Cylinder/indirect hot water demand.

P5 CL Low flow temperature time DHW (display B4)

The programmed period for changing the set point of the water flow temperature from low to high. The standard factory setting for this function is “OFF”.

12.3.5 Heating and hot water switching time

This function can only be used for an “indirect” programmed boiler (parameter **P4 AA** = 1).

In case there is a heating demand and the unit is operating for this heating demand, also a hot water demand can be activated. A hot water demand always has priority, this means that the unit will switch to hot water operation. When the hot water demand remains for a longer period, there will be no heat supply for/to the central heating system during this period. Not supplying any heat for/to the central heating system might cause undesirable temperature fluctuations. The following parameters can be used to program the preferred settings.

P5 CL Low flow temperature time DHW (display B4)

The period during which the set point of the water flow temperature (to the heating coil(s) of the Indirect DHW Cylinder) will switch from “low” to “high”.

P5 CF Max runtime DHW during CH demand

The programmed period for the boiler to operate for DHW demand in case of a CH demand. After this period the boiler will switch to operate for CH demand, even when there is still a DHW demand.

P5 CM Max runtime CH during DHW demand

The programmed period for the boiler to operate for CH demand in case of a DHW demand. After this period the boiler will switch to operate for DHW demand, even when there is still a CH demand.

The standard factory setting for this function is that the hot water demand always has priority and that no switching between the heat and hot water demand happens, when both are active.

12.3.6 Heating And Hot Water Switching At Sudden Temperature Drop

This function can be used to detect an Indirect DHW Cylinder heat demand in case of a sudden temperature drop within the range between the set point and the (minimum) value at which the boiler is normally switched on. The value chosen for this parameter is the level of the temperature drop detected within one second, at which an immediate indirect hot water demand is activated.

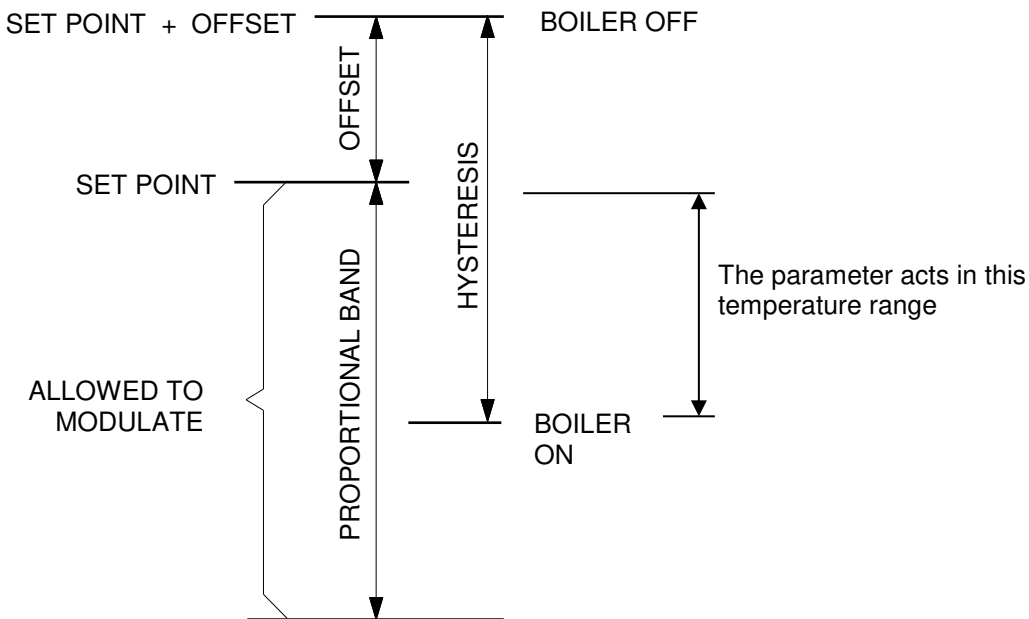

P2KH Gradient heat demand detect Dhw tank temperature (display BG)

See the given explanation. The standard factory setting for this function is “OFF”.

12.3.7 Pasteurisation Programme

This function can only be used for an “indirect” programmed boiler (parameter **P4 AA** = 1), on which a DHW program is active.

The boiler (software) provides a function for heating up the hot water storage tank (once a week) to a higher water temperature than the normal active hot water set point. Also the period, that this “higher” water temperature function must be active, can be programmed.

NOTICE: The standard factory setting for this function is “OFF”. To activate this function some parameters must be programmed by the manufacturer/supplier. The starting day and time of this function can be programmed at the control panel of the boiler.

There are several parameters being used for this function. Three of these parameters are shown in the following graph.

With parameter P2 KI the heating (CH) demand can be interrupted to provide heat for the anti-Legionnaires’ disease demand. When no interruption is activated the boiler will wait for the end of the heat demand before the anti-Legionnaires’ disease function starts. The standard factory setting for this function is “OFF”.

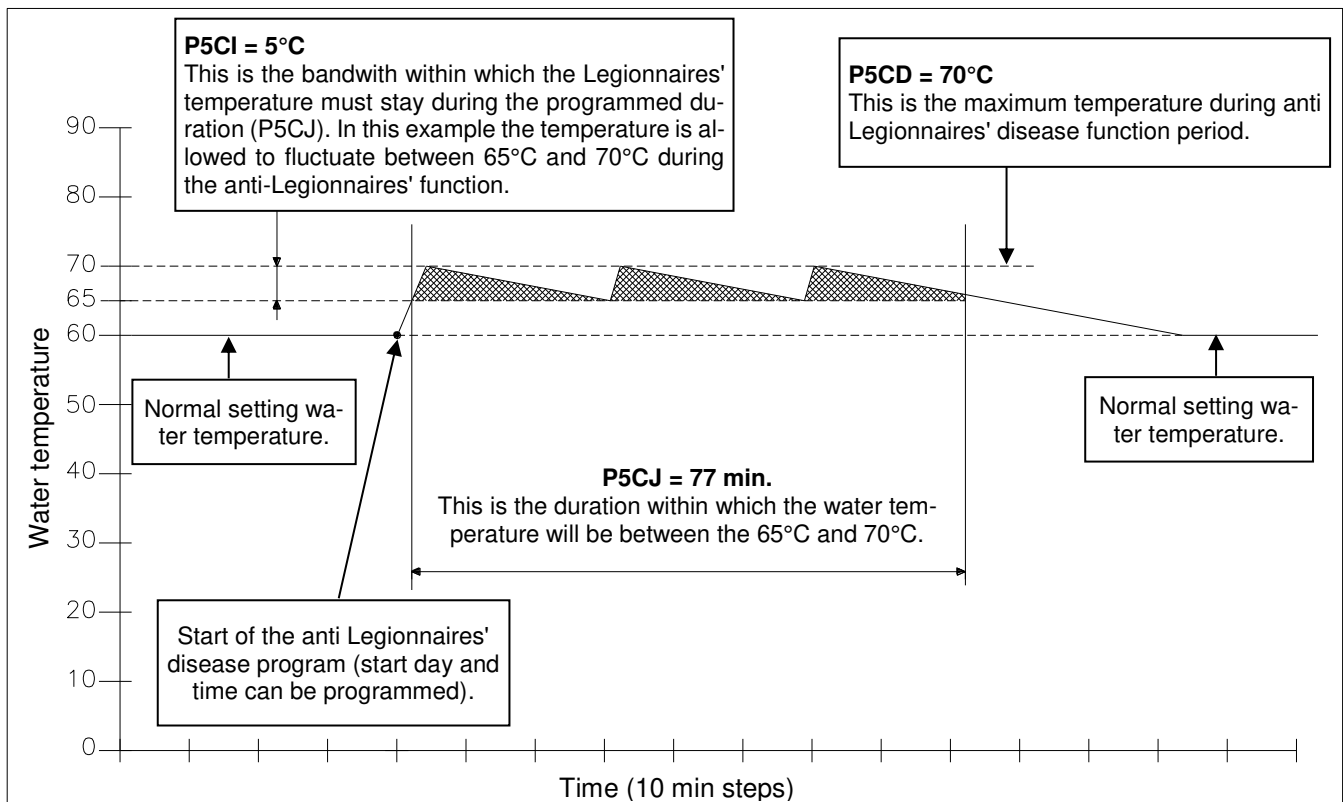

Curve and values only for illustration purposes, programmed parameter values can deviate!

The settings of these parameters **P5 CI**, **P5 CJ** and **P5 CD** must be programmed according the recommendations and requirements within L8.

The setting of these parameters can only be done by the manufacturers commissioning engineer or by a technician with access to programming level 2 at the control panel of the unit without the use of a computer.



The use and activation of this function cannot guarantee a Legionnaires’ disease free installation. The responsibility for monitoring the installation remains with the end-user/owner who should fully comply with the guidance given in L8.

12.4 CASCADE CONTROL

Before commissioning a cascade installation, a number of parameters have to be changed. These parameters can be programmed on the unit itself, without the use of a computer.



Changes in parameter may only be carried out by a skilled commissioning/service engineer, who has had specific training for setting up the CPM range boilers. They will be able to check whether the installation functions correctly after the parameter change has been done.

For programming **all parameters** of the boilers one needs to have a laptop with the appropriate Lochinvar Limited software and an interface cable for connecting the laptop to the boiler control. This software is used for programming but also shows all measured temperatures and cascade behaviour during operation and service/fault history.

12.4.1 Parameter Settings For Cascaded Boilers

Before programming the cascaded boilers, make sure that all boilers are connected (wire) with each other. Use connection 17 and 18 of each boiler.



Do not swap these connections, 17 must always go to 17 and 18 must always go to 18

After connection every boiler must be programmed. This can be done at the control panel. Press the [MENU] button and select the [PARAMETER] menu. See graphics below.

Operating screen:																			
H	E	A	T	I	N	G	:	S	T	A	N	D	-	B	Y				
>	>	>	:	1	2	3	.	4	°	C	(1	2	3	.	4	°	C)

↓
Press [MENU]

Main menu screen:																			
M	a	i	n		M	e	n	u											
S	e	t		p	o	i	n	t	s										

↓
Select "Parameter" using [◀] & [▶] and press [ENTER]

After this, use the password for installer's level 2.

Parameter menu:																			
I	n	s	t	a	l	l	e	r		c	o	d	e						
									0	0	0	0							

↓
Enter the 4-digit code with the [◀] & [▶] and the [▲] & [▼] buttons and select [ENTER]
The code will flash a few seconds and when entered correctly, the following parameters will be displayed.

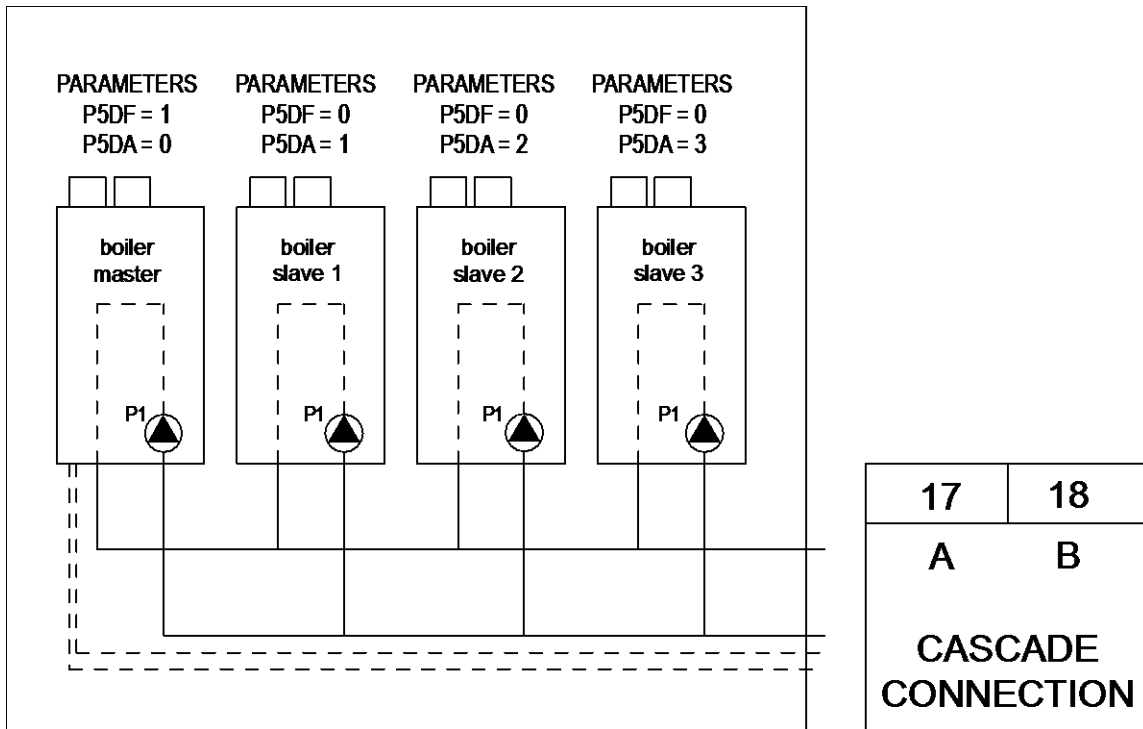

Now for every single boiler of the cascade the following two parameters must be selected and programmed according to the above drawing.

Master:

C5 P5 DF1
C2 P5 DA 0

Slave 1:

C5 P5 DF0
C2 P5 DA 1

Slave 2:

C5 P5 DF0
C2 P5 DA 2
And so on.

Menu C: Cascade																				
C	5					C	a	s	S	i	/	M	a							
										0										
Function for the cascading of the boiler(s). This parameter sets the function of the boiler at a cascade alignment 0 = Single / Slave unit 1 = Master unit																				

Menu C: Cascade																				
C	2					B	u	s	a	d	d	r	e	s	s					
											0									
Function for the cascading of the boiler(s). This parameter determines the address of the boiler for the total cascading control. Master = 0, Slave1 = 1, etc.																				

When the correct parameter is set, this must be confirmed at the confirmation screen. After activation, the value will flash for a few seconds while the parameter is programmed into the boiler.

When cascade connection is programmed correctly the boiler display will show the following.

Explanation "Cascade communication indicator"

NO CASCADE COMMUNICATION

> > > no.1

Always showing the fixed ">>>"

CORRECT CASCADE COMMUNICATION

> > > no.1

> > > no.2

Showing alternating no.1 & no.2 with 1 second interval.

12.4.2 Monitor Screens

To obtain cascade information, see 11.4.

12.4.3 Output Control And Boiler Sequence

The total cascade set-up will act as one single big boiler, switching on- and off boilers, depending on the total load necessary to adjust and keep the flow temperature at the calculated value.

When the heat demand rises, more boilers are switched on, and when heat demand falls, one or more boilers will be switched off. The boiler that was switched on last, will be switched off first, see table below.

To distribute operating hours equally over all boilers, the working sequence of the boilers will change every two hours.

Hour	Switching ON sequence	Switching OFF sequence
X	Master – Slave 1 – Slave 2 – Slave 3 – Slave 4 – Slave 5 – Slave 6 – Slave 7	Slave 7 – Slave 6 – Slave 5 – Slave 4 – Slave 3 – Slave 2 – Slave 1 – Master
X+2	Slave 7 – Master – Slave 1 – Slave 2 – Slave 3 – Slave 4 – Slave 5 – Slave 6	Slave 6 – Slave 5 – Slave 4 – Slave 3 – Slave 2 – Slave 1 – Master – Slave 7
X+4	Slave 6 – Slave 7 – Master – Slave 1 – Slave 2 – Slave 3 – Slave 4 – Slave 5	Slave 5 – Slave 4 – Slave 3 – Slave 2 – Slave 1 – Master – Slave 7 – Slave 6
X+6	Slave 5 – Slave 6 – Slave 7 – Master – Slave 1 – Slave 2 – Slave 3 – Slave 4	Slave 4 – Slave 3 – Slave 2 – Slave 1 – Master – Slave 7 – Slave 6 – Slave 5
.....

Table: boiler sequence example of an eight boiler cascade.

In this table a total of eight boilers (one master, seven slaves) is mentioned as an example, in practice the maximum number in a cascade, without extra (external) control, is twelve boilers.

13 COMMISSIONING THE BOILER

13.1 FIRST: FLUSHING THE BOILER WITH WATER

The system should be thoroughly flushed in accordance with CIBSE Commissioning Codes B & W and BSRIA AG1/2001.1: Pre-commission cleaning of pipework systems.

Check the system for leaks and repair as necessary. If the system is configured in a sealed arrangement, check the expansion vessel cushion pressure and pressurisation unit settings.

13.2 SECOND: FILLING & VENTING THE BOILER AND THE SYSTEM

After flushing the boiler and the installation the system can be filled with fresh water. Fill the boiler and the heating system by using the appropriate filling valve. The water pressure of the system normally lies between 1.5 and 2.0 bar – see § 6.18 'Water pressure' on page 18.

Use the following aspects to prevent corrosion of the central heating system:



Ensure that any plastic pipes used within the system are oxygen diffusion-proof in accordance with DIN 4726/4729. If not, make sure that the boiler circuit is separated from the heating circuit by a plate heat exchanger to prevent oxygenated water circulating around the boiler(s)

The boiler has an automatic air vent situated on top. This vent must be opened during the filling of the boiler and the heating system to make sure that no air/oxygen is trapped in the heat exchanger of the boiler.



Check that the screw cap has been loosened at least one twist. Shortly after putting the boiler into operation, check the water pressure and add water if required to obtain the required pressure.



Make sure that no water can enter the boiler and make contact with the electrical parts.

13.3 THIRD: CHECK THE WATER FLOW

Before the boiler is started for the first time please ensure that the boiler pump is functioning and that there is a water flow over the heat exchanger. Check the electrical power supply of the boiler; if this is connected correctly, the display will show:

Display message	B o i l e r o f f
------------------------	-------------------

Reason Boiler is not active. To activate the boiler press [ON/OFF] button for six seconds.

Display message	H E A T I N G : b o i l e r o f f
	> > > : 1 2 3 . 4 ° C (1 2 3 . 4 ° C)

Reason Boiler is standby. To activate the boiler press [ON/OFF] button for three seconds.

Activate the boiler by pressing the [ON/OFF] button for six resp. three seconds. After this the following display will appear:

Display message	H E A T I N G : N o d e m a n d
	> > > : 1 2 3 . 4 ° C (1 2 3 . 4 ° C)

Reason Boiler is active, but there is no heat demand.

When no water is present in the boiler or the water pressure is too low or high, the boiler will go into lock-out and will show a corresponding message in the display.

Display message	W a t e r p r e s s u r e f a u l t
	9 9 9 , 5 h r s

Reason Water pressure is too low or high.

By pressing the [SERVICE] button of the boiler, the boiler can be started without a heating demand. The boiler will start to fire and also the pump will start to run. Firing of the boiler without water flow (but filled with water!) will cause “boiling noises”. Check during this “service function” operation also the flow and return temperatures of the boiler by pressing the [◀] button once. The temperature difference of the flow and return must be between 13°C and 25°C at high fire. This temperature difference indicates that there is a sufficient water flow over the boiler; this water flow protects the heat exchanger against possible damage caused by a thermal overload.

Another safety feature of the boiler, to make sure that there is enough water flow over the boiler, is the monitoring of the flow and return temperatures (T1 and T2). When the temperature difference (delta T) between the flow and return exceeds a certain (set) value, the following warning messages will be shown in the display.

Display message	T 2 - T 1	h i g h																
										9 9 9 , 5	h r s							

Reason Temperature difference T2-T1 has exceeded the blocking value, as set in the parameters.

Display message	d T	B l o c k																
										9 9 9 , 5	h r s							

Reason Temperature difference between flow and return has exceeded the blocking value, but not the lock out value.

When the T1-T2 value exceeds the lock-out setting, the boiler will switch off and the following lock out code will be shown at the display.

Display message	F l o w R e t u r n	d t	f a u l t															
	F16	p u m p o n								9 9 9 , 5	h r s							

Reason Temperature difference between flow and return exceeds limitation value, or ‘dT block or delta direct block’ has occurred three times.

When these messages appear and/or the boiler locks out, it shows that there is not enough flow over the boiler. Check that the built in pump is working correctly.

The boiler has no built in water-flow switch. If there is the possible risk of a water-flow blockage of the (external) heating system, the following pre-cautions can be taken to ensure a water flow over the boiler:

- Separate the boiler circuit from the (external) heating circuit by using a low loss header or plate heat exchanger.

During and after the commissioning of the boiler, the operation of the boiler pump must be checked, before leaving the installation room.



Always check the pump is working correctly before firing the boiler.

14 STARTING THE BOILER

14.1 GENERAL

Check the gas pressure available at the gas connection pipe of the boiler. Use the pressure nipple (3) of the gas safety valve for this measurement.

The graphs on page 106 show the position of the test nipple (3) for the complete boiler range.

The gas input pressure for the boiler to operate properly under the correct load, must be at high fire more or equal to the minimum gas inlet pressure for the supplied gas type, as stated in the technical specification data table on page 7.

14.2 FIRING FOR THE FIRST TIME

After the commissioning of the boiler and the described previous actions, the boiler display will show the following graph.

Display message	H	E	A	T	I	N	G	:	N	o	d	e	m	a	n	d				
Reason	>	>	>	:	1	2	3	.	4	°	C	(1	2	3	.	4	°	C)

The display describes:

- The actual operation for heating or hot water
- If there is a heat demand activated
- The temperature setting
- The temperature measured



When mounting the bottom part of the siphon, before commissioning the boiler and/or after maintenance, it must ALWAYS be completely filled with water.

This is a safety measure: the water in the siphon keeps the flue gases from leaking out of the heat exchanger via the condensate drain.

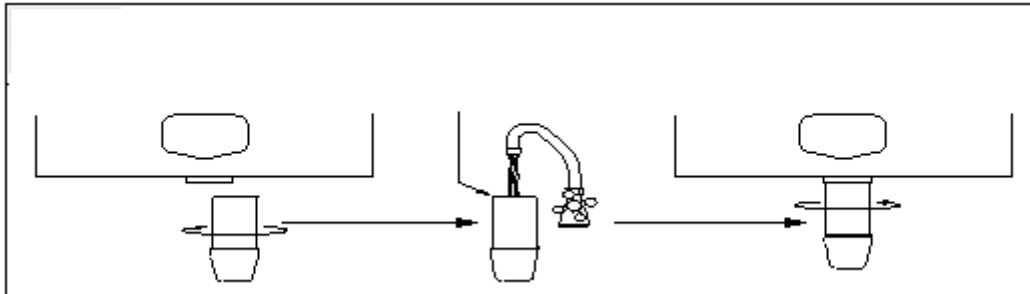

When the boiler receives a heat demand the electronics will start the operation of the boiler. Before the boiler is used, the boiler burner must be adjusted and set at the minimum and maximum load.

15 ADJUSTING AND SETTING THE BURNER



Before carrying out any adjustments to the burner, carefully read this complete chapter.

15.1 INTRODUCTION

The burner must always be adjusted when:

- A.** - A new boiler is installed
 - As part of a service/maintenance check, in case the CO₂ values turn out to be incorrect

Adjustment procedures for the above can be found in § 15.2.

- B.** - The gas control safety valve has been (re)placed
 - Another type of gas is applied: gas conversion

Adjustment procedures for the above can be found in § 15.3.

In either of the four cases described in **A** and **B**, always check the gas/air ratio of the combustion figure (CO₂) at maximum and minimum input. First set the boiler at maximum load and subsequently at minimum load, and repeat if necessary.

Gas types and valves

The right type of valve must be selected, depending on the gas type. Gas types G20, G25 and G31 are commonly used; the boilers are equipped as standard with the A+C-class valves required for these types of gas.

Set-up of this chapter:

First, all necessary values are given in three tables in § 15.1.1. A drawing of the gas valve(s) and setting screws is given in § 15.1.3 on the next page. In § 15.1.5 a general scheme to ensure you fully comply with these instructions using the correct procedure, A or B. After that, in §§ 15.2 and 15.3, a thorough description is given of how to proceed in cases **A** and **B** respectively. In § 15.4, finally, two main procedures used in the previous sections are described in detail.

15.1.1 Adjustment tables

Table 1 CO₂ values for maximum and minimum load

boiler type	load	output	gas type:		
			Natural gas G20 ¹ , G25 ¹ ,	propane ³ G31 ¹	butane (B/P) ³ G30 ¹ /G31 ¹
CPM 58-116 ²	max. load	CO ₂ (%)	9.0 - 9.2	10.3 - 10.5	10.4 - 10.6
		O ₂ (%)	4.5 - 4.8	4.9 - 5.2	5.1 - 5.4
	min. load	CO ₂ (%)	8.5 - 8.7	9.1 - 9.3	9.1 - 9.3
		O ₂ (%)	5.4 - 5.7	6.7 - 7.0	7.0 - 7.3
CPM 144 ²	max. load	CO ₂ (%)	9.0 - 9.2	10.4 - 10.6	10.5 - 10.7
		O ₂ (%)	4.5 - 4.8	4.7 - 5.0	4.9 - 5.2
	min. load	CO ₂ (%)	8.5 - 8.7	9.1 - 9.3	9.1 - 9.3
		O ₂ (%)	5.4 - 5.7	6.7 - 7.0	7.0 - 7.3
CPM 175 ²	max. load	CO ₂ (%)	9.0 - 9.2	10.5 - 10.7	10.6 - 10.8
		O ₂ (%)	4.5 - 4.8	4.6 - 4.9	4.8 - 5.1
	min. load	CO ₂ (%)	8.5 - 8.7	9.1 - 9.3	9.1 - 9.3
		O ₂ (%)	5.4 - 5.7	6.7 - 7.0	7.0 - 7.3

¹ Cf. EN437.

² All values are measured without boiler door fitted. The CO₂ / O₂ values should always be between the values set in this table. Nominal values can be found in Technical specifications datasheet page

³ Fan settings must be changed by altering parameter P4BD (display D8) (only by a skilled Service Technician)

15.1.2 Adjustment values

To make adjustments easier, values of table 1 are presented in the following figures. The CO₂ / O₂ values should always be between the values set in this figure. Nominal values can be found in the Technical specifications datasheet at the beginning of this manual. All values are measured **without** boiler door fitted.

Gas type G20

The CO₂ level may never be in the hatched area.

CPM58-CPM116

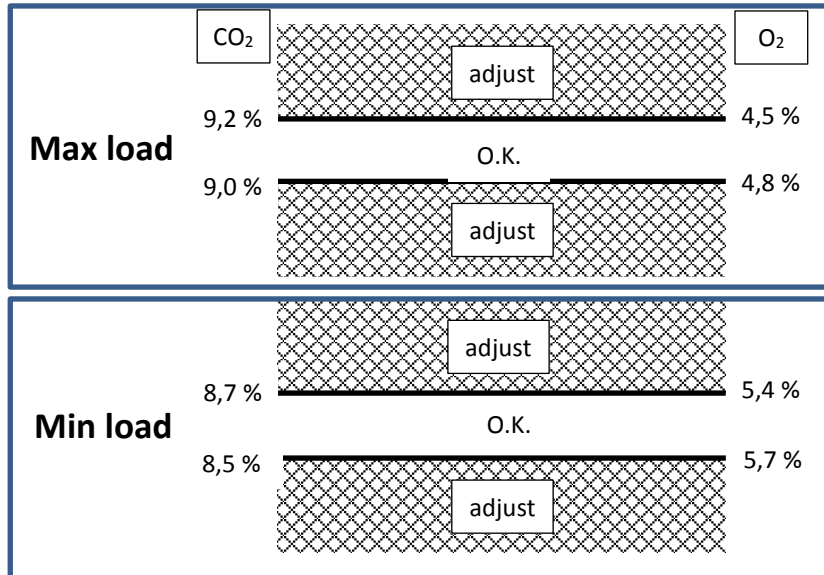

Propane G31:

Fan settings must be changed by altering parameter P4BD (display D8). (only by a skilled Service Technician). The CO₂ level may never be in the hatched area.

CPM58-CPM116

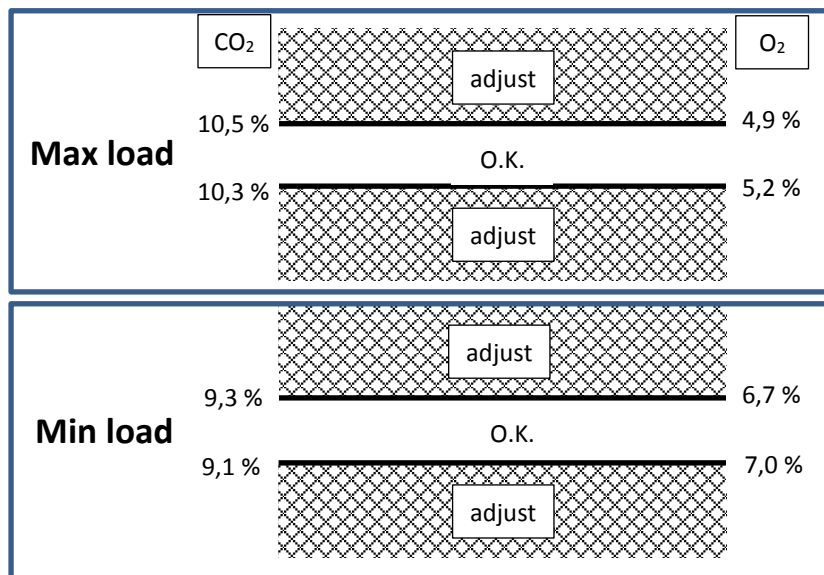

>>> cont. Propane G31:

The CO₂ level may never be in the hatched area.

CPM144

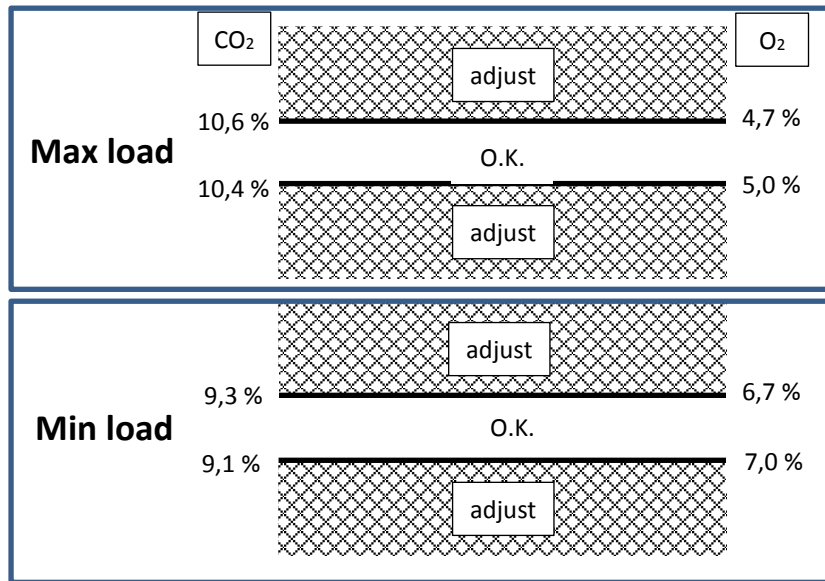

CPM175

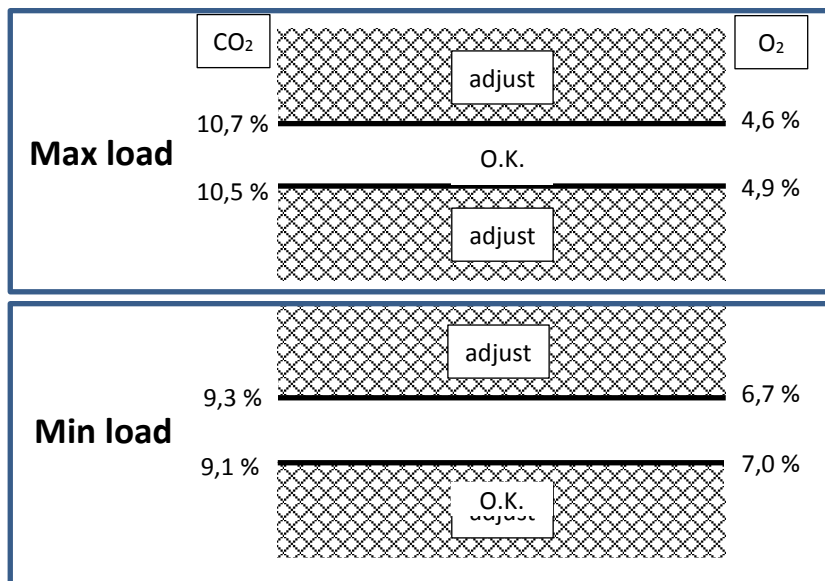

B/P: propane/ butane mixture G30/ G31:

Fan settings must be changed by altering parameter P4BD (display D8). (only by a skilled Service Technician).
The CO₂ level may never be in the hatched area.

CPM58-CPM116

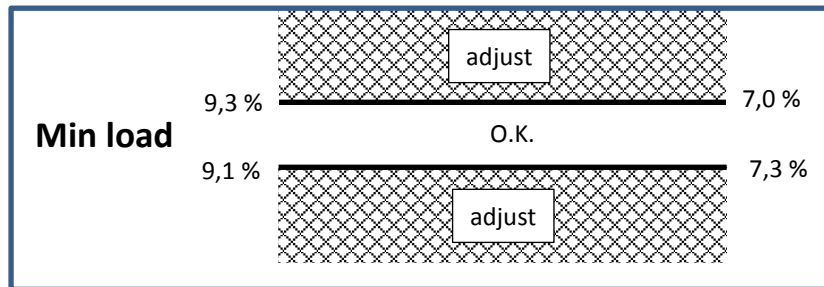
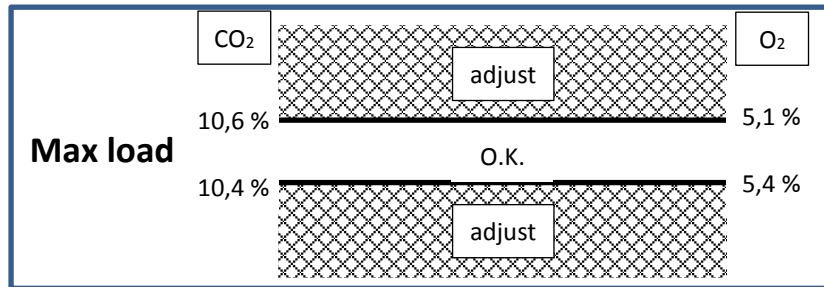

CPM144

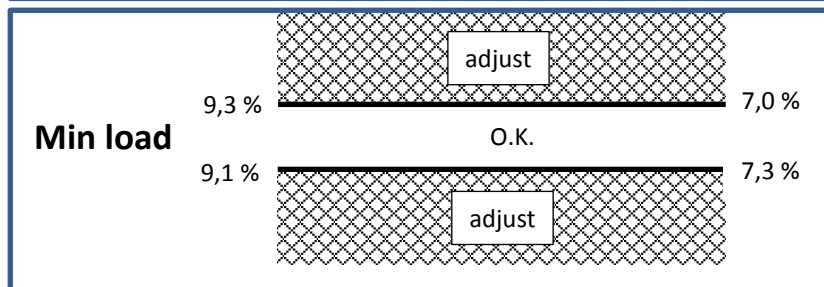
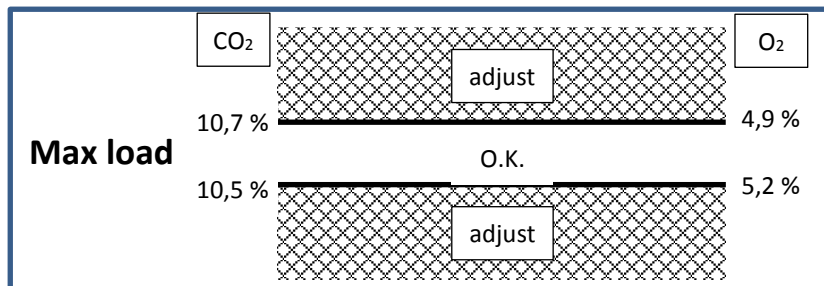

CPM175

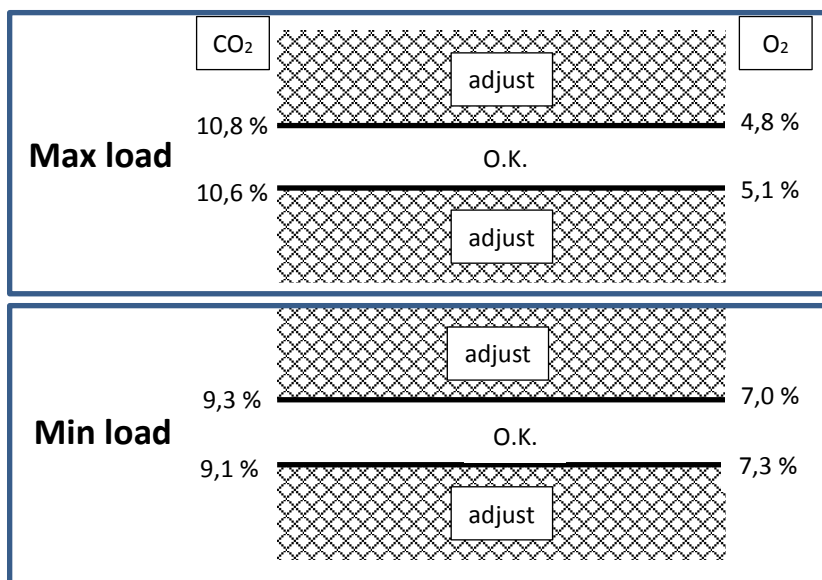

Table 2 pre adjustment settings gas valves

boiler type	number of turns open (counter clockwise)		
	nat. gas G20 / G25	propane G31	butane G30/G31 (B/P)
CPM 58	1	0.5	0.25
CPM 77	1.5	0.75	0.5
CPM 96	3.5	1.5	1.25
CPM 116	2.25 *	1 *	0.75 *
CPM 144	2.25 *	1 *	0.75 *
CPM 175	4.25 *	2.25 *	2 *

* Both gas valves must be opened this number of turns.

Table 3 Pressure adjustment settings LEFT valve

boiler type	"p-out" pressure at gas valve		
	nat. gas G20 / G25	propane G31	Butane/Propane B/P G30/G31
CPM 116	-2 to 0 Pa	-4 to -2 Pa	-5 to -3 Pa
CPM 144	-2 to 0 Pa	-7 to -5 Pa	-8 to -6 Pa
CPM 175	-2 to 0 Pa	-7 to -5 Pa	-8 to -6 Pa



Maximum fan speed has to be reduced to convert the boiler into a propane or B/P appliance. Setting of parameter P4BD.

A sticker has to be pasted after converting the boiler into a propane or B/P appliance. Mark the used gas and the parameter setting on this sticker.

G31 P	PROPANE PROPAN PROPANO PROPAAN	<input type="text"/>	P4BD = 1	<input type="text"/>
	G30/G31 B/P	BUTANE/PROPANE BUTAN/PROPAN BUTANO/PROPANO BUTAAN/PROPAAN	<input type="text"/>	P4BD = 2

15.1.3 Setting screws gas valve(s): drawings

NOTICE: Do NOT mistake the screw marked 'PILOT' for screw 2.
 → Screw 2 is the SMALL screw immediately next to the pilot screw.

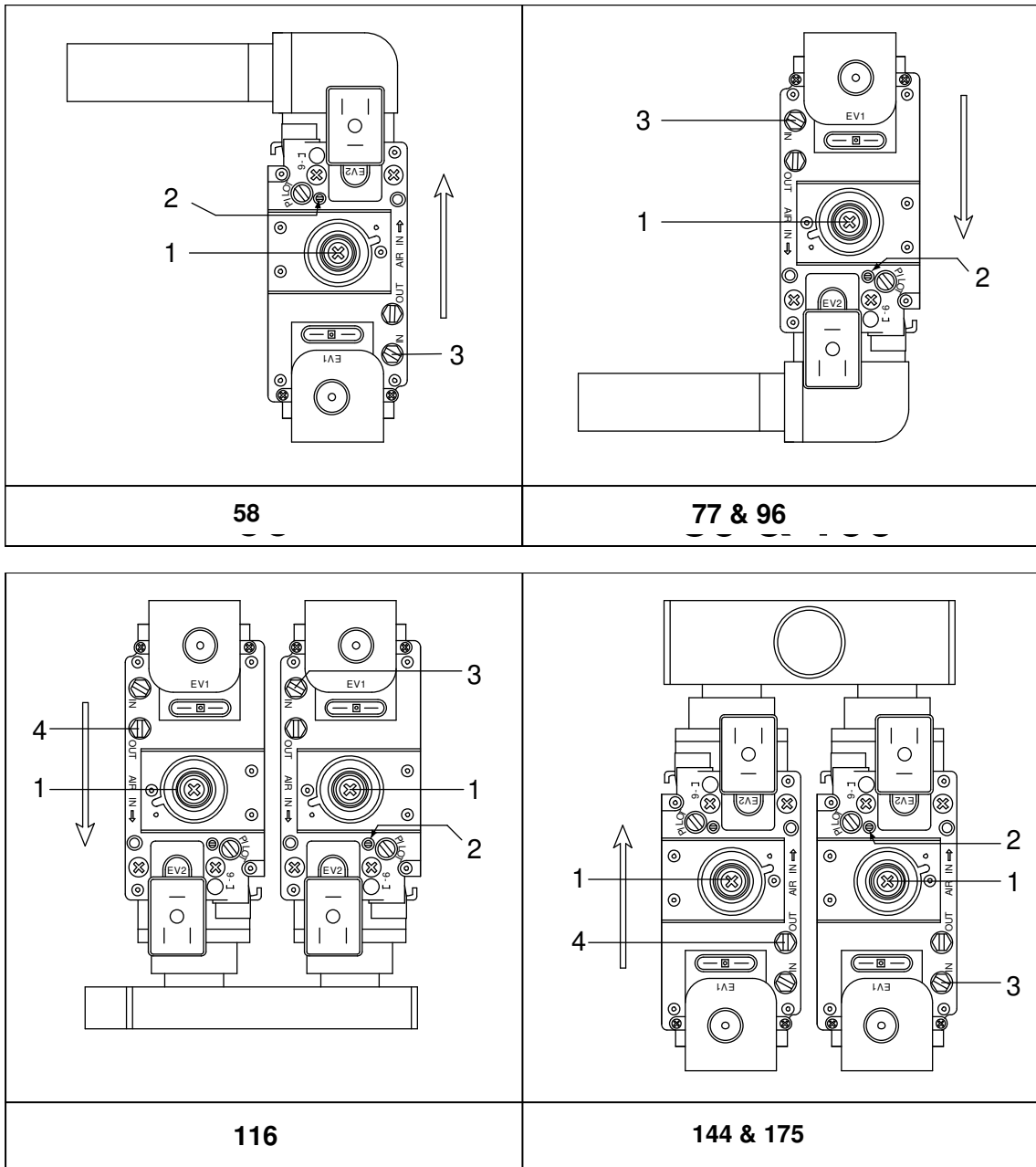

15.1.4 Gas valve classes A+C and B+J (For the UK the gas valve should be the a+c type)

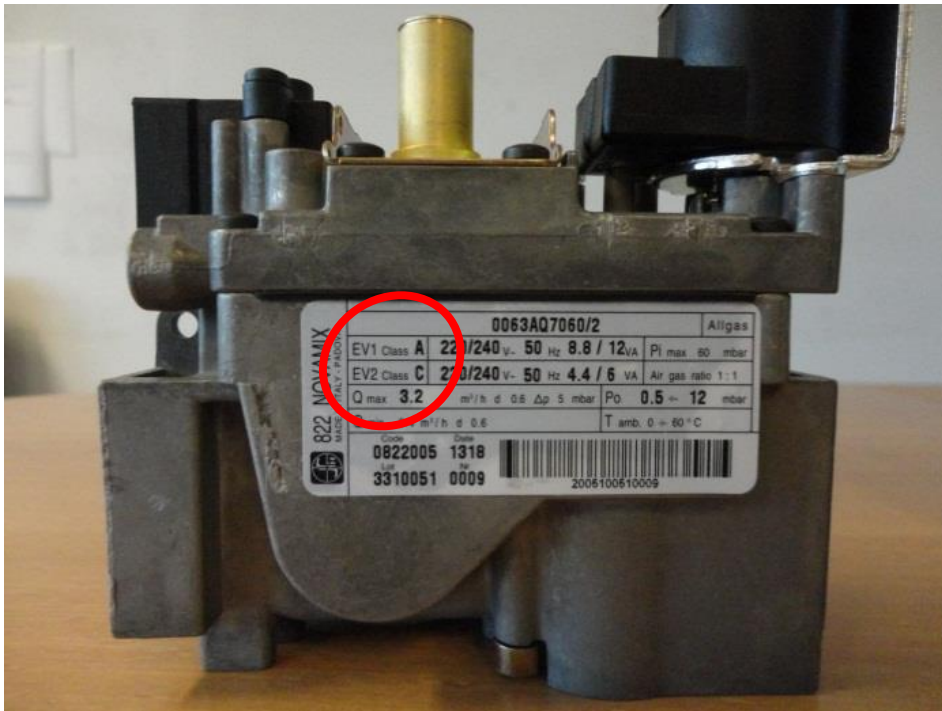

These pictures show the difference between an A+C and a B+J valve. Notice the class being denoted on the ID plate of the valve.

15.1.5 Adjustment actions: general scheme

General scheme for adjustment of the gas valve(s). Check this scheme for an overview.

To complete all necessary adjustments in right order, follow case **A** or **B** top-down through the scheme (**B** involves a few extra steps (grey text blocks)):

GENERAL SCHEME SETTING STEPS							
	case A new boiler or service check	case B valve replacement or gas conversion					
	continue ↓	first close (both*) screw(s) [2], then set them in accordance with table 2					
	SWITCH TO SERVICE MODE						
	continue ↓	If burner doesn't start, open (RIGHT*) screw[2] ¼ turn extra					
	setting at maximum load						
procedure 1	[▲] set burner at maximum load						
	measure CO ₂ at flue gas outlet; use (RIGHT*) screw [2] to Adjust as per table 1 or figures						
	<table border="1" style="margin-left: auto; margin-right: auto;"> <tr> <td style="text-align: center;">CO₂ ↓</td> <td style="text-align: center;">[2]</td> </tr> <tr> <td style="text-align: center;">CO₂ ↑</td> <td style="text-align: center;">[2]</td> </tr> </table>			CO ₂ ↓	[2]	CO ₂ ↑	[2]
CO ₂ ↓	[2]						
CO ₂ ↑	[2]						
	setting at minimum load						
	continue ↓	only → CPM 116, 144, 175	[▼] set burner at minimum load				
			use LEFT screw [1] to match "p-out" with table 4				
procedure 2	[▼] set burner at minimum load						
	measure CO ₂ at flue gas outlet; use (RIGHT*) screw [1] to Adjust as per table 1 or figures						
	<table border="1" style="margin-left: auto; margin-right: auto;"> <tr> <td style="text-align: center;">CO₂ ↓</td> <td style="text-align: center;">[1]</td> </tr> <tr> <td style="text-align: center;">CO₂ ↑</td> <td style="text-align: center;">[1]</td> </tr> </table>			CO ₂ ↓	[1]	CO ₂ ↑	[1]
CO ₂ ↓	[1]						
CO ₂ ↑	[1]						
repeat procedure 1							
repeat procedure 2							
keep repeating until values match table values best							
Boiler returns to NORMAL MODE after 40 min. OR by pressing [SERVICE] button							

* in case of a double valve (CPM 116, CPM 144, CPM 175)

For an extensive description consult the next two sections (choose which is applicable, **A** or **B**):

15.2 ADJUSTING: NEW BOILER, OR AFTER MAINTENANCE (CASE A)

15.2.1 General remark

For all adjusting steps under **A** the measured CO₂ values shall be according table 1 or figures

15.2.2 Checking and adjusting at maximum load

Adjust at maximum load by carrying out procedure 1 on p.94.

15.2.3 Checking and adjusting at minimum load

Adjust at minimum load by carrying out procedure 2 on p.94.

15.3 ADJUSTING: GAS VALVE REPLACEMENT OR GAS CONVERSION (CASE B)



Maximum fan speed has to be reduced to convert the boiler into a propane or B/P appliance. Setting parameter P4BD.

15.3.1 General remarks

In case **B**, a distinction is made between the setting of boilers containing a single valve (CPM 58-CPM 96) and boilers with a double valve (CPM 116-CPM 175).

All adjustments must result in CO₂ according table 1 or figures.

Checking and adjusting at maximum load CPM 58, CPM 77, CPM 96

These boilers all have single gas valves, see the drawings on page 15.1.3102.

- First, turn setting screw [2] of the gas valve clockwise until you feel resistance. This means that the valve is closed, *do not try to tighten the screw any further.*
- Now turn screw [2] counter clockwise (open), according to the number of turns in table 2 or 3 for the used boiler and gas type.

After this, adjust at maximum load by carrying out procedure 1 on page 110.

If the burner doesn't start up in service mode, turn screw [2] a quarter turn counter clockwise further open, and try again.

15.3.2 Checking and adjusting at minimum load CPM 58, CPM 77, CPM 96

Adjust at minimum load by carrying out procedure 2 on page 94.

IMPORTANT: Toggle between high fire and low fire to make fine-tuning adjustments (adjusting the minimum setting affects the maximum setting and contrariwise).

In case of gas conversion, paste the corresponding sticker at the appropriate position in the water heater and mark the square for the used gas type. Also mark the square, indicating that the correct value has been set for parameter P4BD.

G31 P	PROPANE PROPAN PROPANO PROPAAN	<input type="checkbox"/>	P4BD = 1	<input type="checkbox"/>
G30/G31 B/P	BUTANE/PROPANE BUTAN/PROPAN BUTANO/PROPANO BUTAAN/PROPAAN	<input type="checkbox"/>	P4BD = 2	<input type="checkbox"/>

(In the example on the right, 'propane' and 'P4BD = 1' have been marked).

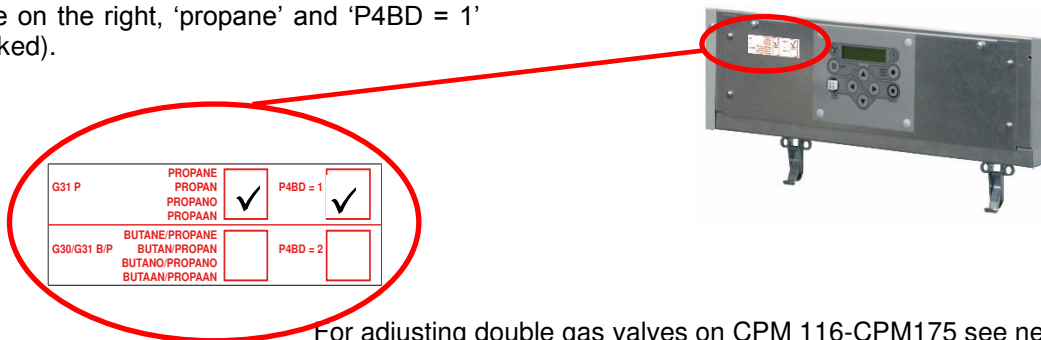

For adjusting double gas valves on CPM 116-CPM175 see next page →

15.3.3 Checking and adjusting at maximum load CPM 116, CPM 144, CPM 175

The boilers CPM 116, CPM 144, CPM 175 all have double gas valves, see the drawings on page 88.

First connect a manometer to "p-out" = measuring point [4] of the **left** gas valve (see drawing).

- Now, turn setting screws [2] of both gas valves clockwise until you feel resistance. This means that the valves are closed; do not try to tighten the screws any further in the closed position.
- After this, turn screws [2] of both left and right hand gas valve counter clockwise (open), according to the number of turns in table 2 or 3 for the used boiler and gas type.

From now on **only** use the **right hand** gas valve for adjustments on high fire.

Adjust the right valve at maximum load by carrying out procedure 1 on page 94.

If the burner doesn't start up in service mode, turn screw [2] a quarter turn counter clockwise further open, and try again.

15.3.4 Checking and adjusting at minimum load CPM 116, CPM 144, CPM 175

Adjusting these boilers at minimum load in case B involves extra measurements, to get both valves balanced:

Use the [▼] button to decrease the actual load of the service (percentage) to the minimum. The following screen will appear:

Display message	H	E	A	T	I	N	G	:	S	e	r	v	i	c	e		2	6	%	
	>	>	>		1	2	3	.	4	°	C	(1	2	3	.	4	°	C)

Boiler is activated and operates at service mode at 26% (minimum).

See table 4 for pressure settings "p-out" gas valve for the used boiler and gas type.

Use screw [1] on the **left hand** gas valve to adjust the measured pressure at "p-out" to the right value according to table 4. Be sure the manometer has been zeroed out prior to making this setting.

Below, the influence of turning screw [1] is described.

- Turning counter clockwise → less gas → a drop in CO₂ → a drop in measured pressure at "p-out"
- Turning clockwise → more gas → a rise in CO₂ → a rise in measured pressure at "p-out"

After "p-out" has been set according table 4, the CO₂ level at low fire has to be set again. Use values of table 1 and/or figures.

Adjust screw [1] of the **RIGHT hand** valve to set the CO₂ at minimum load by carrying out procedure 2 on page 111.

Again, toggle between high fire and low fire to make fine-tuning adjustments (adjusting the minimum setting affects the maximum setting and vice versa).

If the valves have been set correctly, "p-out" left should equal "p-out" right. As an additional test, one could check this by measuring "p-out" at the RIGHT valve, i.e. at measuring point 4 on the right valve (not denoted in the drawings on page 89).

This pressure should be in the same range of pressure as the left valve, so in accordance with table 4 again.

If, after all setting steps have been carried out properly, the values of left and right "p-out" are still very different, contact your supplier.

15.4 ADJUSTING PROCEDURES

Procedures 1 and 2, referred to in the previous sections 15.2 and 15.3, are described here:

15.4.1 Procedure 1: adjust at maximum load

In case B (replacement of gas valve or gas conversion): consult § 15.3. Before starting procedure 1 below.

Carry out the next 4 steps:

1. Press [SERVICE] button for about 3 seconds.

Display message	H	E	A	T	I	N	G	:	S	e	r	v	i	c	e		2	6	%	
	>	>	>		1	2	3	.	4	°	C	(1	2	3	.	4	°	C)

Boiler is activated and operates at service mode at 26% (minimum). (example)

2. Press [▲] button until maximum load is reached:

Display message	H	E	A	T	I	N	G	:	S	e	r	v	i	c	e		1	0	0	%
	>	>	>		1	2	3	.	4	°	C	(1	2	3	.	4	°	C)

Boiler is activated and operates at service mode at 96% (maximum). (example)

3. Measure the CO₂ percentage at the flue gas outlet.
4. By setting screw [2], adjust the gas valve to obtain the CO₂ value of table 1 or the figures.
NOTICE: For the CPM 116, 144 and 175 boilers use only the RIGHT side gas valve for adjusting.

Decrease CO₂ percentage

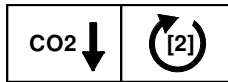

Turn screw [2] right (clockwise)

Increase CO₂ percentage

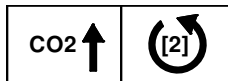

Turn screw [2] left (counter clockwise)

The service operation of the boiler will be active for 40 minutes. After this period the boiler will return to normal operation.

15.4.2 Procedure 2: adjust at minimum load

In case **B** (gas conversion or replacement of gas valve): consult § 15.3. before starting procedure 2 below.

Carry out the next three steps:

1. Press [▼] button until minimum load is reached.

Display message	H	E	A	T	I	N	G	:	S	e	r	v	i	c	e		2	6	%	
	>	>	>		1	2	3	.	4	°	C	(1	2	3	.	4	°	C)

Boiler is activated and operates at service mode at 26% (minimum).

2. Measure the CO₂ percentage at the flue gas outlet.
3. By setting screw [1], adjust the gas valve to obtain the CO₂ value of table 1.
NOTICE: For the CPM 116, 144 and 175 boilers use only the RIGHT side gas valve for adjusting.

Decrease CO₂ percentage

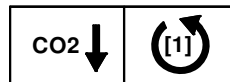

Turn screw [1] left (counter clockwise)

Increase CO₂ percentage

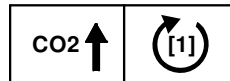

Turn screw [1] right (clockwise)

The service operation of the boiler will be active for 40 minutes. After this period the boiler will return to normal operation.

17 FAULT CODES. BLOCKING CODES

17.1 FAULT CODES



To avoid electric shocks, disconnect electrical supply before performing troubleshooting.



To avoid burns, allow the unit to cool before performing troubleshooting.

IMPORTANT:

Be aware that a fault code is an indication that the unit or the system needs attention. When repeatedly having faults these should not be neglected. The first step is to check if the unit is installed according to the instructions. If not, first make sure the installation complies with the installation manual. Always check the fuses on the control board before replacing any major components. A blown fuse can prevent the controller or other components from operating. Most faults can also be caused by a bad wiring and/or connections, even if it is not specifically mentioned. With every fault it is wise to check wiring and connections (at both ends) that connect to the safety device/component that generates the fault.

LOCK-OUT CODES:

Having a lockout means that the boiler needs a manual reset to start operating again. When the boiler is in lockout the backlight of the display is flashing on and off.

Explanation > **9 9 9 , 5 : h r s** = time elapsed after fault/message.

Explanation > **P u m p 1 o n** = status of the pump during fault.

Display message	F l o w s e n s o r e r r o r
F0	p u m p o n 9 9 9 , 5 h r s
Reason:	Flow sensor is not detected.

Cause:

Bad wiring/connection in the flow sensor circuit.

Corrective action:

Check for loose wiring/connections in the flow sensor circuit.

Cause:

Bad temperature sensor causing a fault signal.

Corrective action:

Replace flow sensor.

Display message	F l o w h i g h T e m p
F1	p u m p o n 9 9 9 , 5 h r s
Reason:	Max flow temperature exceeds limitation (lock-out) value.

Cause:

The water flow is restricted.

Corrective action:

Check functioning of the pump.
 Check/open all valves that might restrict the water flow through the unit.
 Check for an external system pump that influences flow through the unit.
 Check if the system resistance exceeds the spare capacity of the unit pump.

Display message F1	R e t u r n h i g h T e m p
	p u m p o n 9 9 9 , 5 h r s
Reason:	Maximum return temperature exceeds limit value.

Cause:	Systems that pre-heats the boiler return temperature too much/high.
Corrective action:	Reduce pre heat temperature of external heat source.

Cause:	The need for heat in the system suddenly drops causing hot return water to the boiler.
Corrective action:	Dampen external heating system control to prevent sudden boiler temperature rise.

Display message F3	R e t u r n s e n s o r e r r o r
	p u m p o n 9 9 9 , 5 h r s
Reason	Return sensor is not detected by the boiler PCB.

Cause:	Bad wiring/connection in the return sensor circuit.
Corrective action:	Check for loose wiring/connections in the return sensor circuit.

Cause:	Bad temperature sensor causing a fault signal.
Corrective action:	Replace return sensor.

Display message F6	F l u e s e n s o r e r r o r
	p u m p o n 9 9 9 , 5 h r s
Reason	Flue sensor is not detected by the boiler PCB.

Cause:	Bad wiring/connection in the flue gas sensor circuit.
Corrective action:	Check for loose wiring/connections in the flue gas sensor circuit.

Cause:	Bad temperature sensor causing a fault signal.
Corrective action:	Replace flue gas sensor.

Display message	F l u e t e m p t o o h i g h
F7	p u m p o n 9 9 9 , 5 h r s
Reason	Flue gas temperature exceeded 3 times limitation value within a certain period.

Cause:	Heat exchanger polluted and not able to transfer enough heat to system water.
Corrective action:	Check and clean heat exchanger.

Cause:	Bad flue gas sensor or sensor connection (partly shorted).
Corrective action:	The sensor is of the type NTC. This means if the temperature rises, the resistance lowers. A partly shorted sensor will drop its resistance and therefore 'measure' a raise in temperature when actually there is none. Check for moisture on the sensor connections or replace sensor.

Cause:	There is no water in the unit while firing.
Corrective action:	This situation is unlikely if all system checks have been performed properly prior to firing the boiler. Check the system and boiler for leaks and/or air in the system and bleed thoroughly. Ensure the boiler air vent has been opened and all air expelled from the heat exchanger.

Cause:	Heat exchanger failure.
Corrective action:	This is an unlikely situation but when there is severe damage to the heat exchanger, the combustion product will not be able to transfer all heat to the system water. The heat that is not transferred will convert to an increased flue gas temperature.

Display message	F a i l e d b u r n e r s t a r t
F8	p u m p o n 9 9 9 , 5 h r s
Reason	Boiler not operational after four starting attempts.

Cause:	No spark.
Corrective action:	Check the ignitor/ignition electrode and replace/clean if necessary. Check the state of the ceramic insulator. A small crack can prevent the spark to form at the end of the electrode. Check the distance between the electrode pin, earth pin and burner. Check the state of the ignition cable and replace if necessary. Check the state of the earth wire/connection of the ignitor and replace if necessary. Check the state of the sparkplug cap and replace if necessary. Check power supply. Voltage must be 230 Vac nom. Check for proper electrical grounding of unit. Bad ignition transformer. Replace the burner control of the unit.

F8 →

Cause:
Bad flue gas and/or air supply system.
Corrective action:
Check if the design of the flue gas and air supply system complies with the maximum combined resistance as specified. Check if the flue gas and air supply system is installed according a good installation practice by a skilled installer. Check all seals in the flue gas and air supply system.

Cause:
External factors.
Corrective action:
Check if there were extreme weather/wind conditions when the fault occurred. Check if the boiler room pressure is equal to the pressure at the position of the flue gas outlet (when combustion air is drawn from the boiler room).

Display message	F a l s e f l a m e s i g n a l
F10	p u m p o n 9 9 9 , 5 h r s
Reason	Flame signal detected, while boiler should not fire for operation.

Cause:
The flame detection circuit detects a flame which is not supposed to be present.
Corrective action:
Check the ignition/ionisation electrode and make sure it is clean (or replace it). Check the power supply voltage for a correct polarity. Check the power supply for bad frequency or voltage peaks. Check external wiring for voltage feedback. Check the internal wiring for bad connections. Check if the gas valve is closing correctly. Replace the burner control.

Display message	F a n s p e e d i n c o r r e c t
F11	p u m p o n 9 9 9 , 5 h r s
Reason	Actual fan speed differs from the unit rpm set point.

Cause:
An incorrect fan speed is detected.
Corrective action:
Check the 4 wired wiring and connections at the fan and at the main control board. Check the 3 wired power supply wiring and connections at both ends. Replace the fan. Replace the main control board.

Display message	p r o g r a m m i n g e n d
F12	p u m p o n 9 9 9 , 5 h r s
Reason	Programming of the parameters completed successfully.

Cause:
Programming of the parameters completed successfully.
Corrective action:
This message occurs to confirm the end of programming. Pressing RESET will return the unit in normal operating status.

Display message F13	P a r a m / H a r d w	f a u l t							
	p u m p o n				9 9 9 , 5			h r s	
Reason	Failure during programming of the parameters.								
Cause:	Programming of the parameters NOT successfully completed.								
Corrective action:	Unit is not in standby mode (fan must not run during programming). Check programming wire and connections and try again. Check if the software complies with the PCB. Replace the programming wire. Replace the display PCB.								

Display message F15	C l i x o n	F a u l t							
	p u m p o n				9 9 9 , 5			h r s	
Reason	Heat exchanger fuse or burner door clixon exceeded maximum allowed value.								

Cause:	The thermal fuse of the heat exchanger has opened permanently.								
Corrective action:	Switch off the electrical power and gas supply and contact supplier.								
Cause:	The burner door clixon has opened.								
Corrective action:	Remove the burner door of the heat exchanger and check the burner door gasket for leakage. Check the burner door for deformation; when it deforms it must be replaced. Check the heat exchanger for dirt and check that the flue is not blocked. If heat exchanger is clean, reset manually the clixon itself and reset the boiler.								

Display message F16	F l o w R e t u r n	d t	f a u l t						
	p u m p o n				9 9 9 , 5			h r s	
Reason:	Temperature difference between flow and return exceeds limitation value, or 'dT block or delta direct block' has occurred three times.								

Cause:	The water flow through the unit is too low.								
Corrective Action:	Check functioning of the pump. Check/open all valves that might restrict the water flow through the unit. Check for an external system pump that influences the flow through the unit. Check if the system resistance exceeds the spare capacity of the unit pump. Make sure the heat exchanger is clean. Heat exchanger fouling (partly blockage) will increase the resistance causing the water flow to drop.								

Display message F17	W a t e r	h i g h	l i m i t						
	p u m p o n				9 9 9 , 5			h r s	
Reason	Maximum thermostat exceeds limitation value.								

Cause:	The water flow is restricted.								
Corrective action:	Check functioning of the pump. Check/open all valves that might restrict the water flow through the unit. Check for an external system pump that influences the flow through the unit. Check if the system resistance exceeds the spare capacity of the unit pump.								

Display message F19	S	i	p	h	o	n	s	w	i	t	c	h								
	p	u	m	p		o	n					9	9	9	,	5			h	r
Reason	Siphon pressure switch detects high pressure in the flue/siphon system.																			

Cause:	There is too much resistance in the flue gas circuit causing high pressure in the heat exchanger at the flue gas side.
Corrective action:	Check if the flue gas system is blocked. Extreme failing of the heat exchanger also causes the resistance to rise. Check the state of the heat exchanger and clean if necessary. Check the flue gas system diameter & length (most likely in a new system).

Cause:	The condensate drain system is blocked. The condensate will build up above the measuring point of the pressure switch and creates a static pressure larger than the measuring point.
Corrective action:	Check if the condensate drain hose between the heat exchanger and the siphon is open, so the condensate can flow freely to the siphon. Check if the siphon is free of debris that might block the condensate flow and clean the siphon if necessary. Check the condensate drain hose between the siphon and the condensate drain point in the external installation. Condensate must be able to flow freely.

Cause:	The condensate drain hose must have an open connection to the external system. If not, pressure fluctuations in the building drainage system can have effect on the pressure in the heat exchanger of the boiler.
Corrective action:	Make sure that there is an open connection between the siphon hose and the drainage system of the building installation. The condensate should flow in the drainage system through a freely "breathing" connection, so pressure fluctuations of the external drainage system cannot affect the pressure in the heat exchanger of the boiler.

Cause:	Blockage of the pressure signal hose going to the pressure switch.
Corrective action:	Check the pressure signal hose and clean or replace if necessary.

Cause:	Bad pressure switch causing a fault signal.
Corrective action:	Replace the pressure switch.

Cause:	Bad wiring/connection in the pressure switch circuit.
Corrective action:	Check for loose wiring/connections in the pressure switch circuit.

17.2 BLOCKING CODES:

The display is not flashing, but is light up during the blocking period.
 The boiler is blocking an action, because of an extraordinary situation. This action will be continued after stabilisation of this situation.

Display message	F l o w t e m p h i g h 9 9 9 , 5 h r s
Reason:	Flow temperature has exceeded the blocking temperature, but it has not exceeded the lock-out value.

Cause:	
The water flow is restricted.	
Corrective action:	
Check functioning of the pump. Check/open all valves that might restrict the water flow through the unit. Check for an external system pump that influences the flow through the unit. Check if the system resistance exceeds the spare capacity of the unit pump.	

Display message	R e t u r n t e m p h i g h 9 9 9 , 5 h r s
Reason	Return temperature has exceeded the blocking temperature, but it has not exceeded the lock-out value.

Cause:	
Systems that pre-heats the boiler return temperature too much/high.	
Corrective action:	
Reduce pre heat temperature of external heat source.	

Cause:	
The need for heat in the system suddenly drops causing hot return water to the boiler.	
Corrective action:	
Dampen external heating system control to prevent sudden boiler temperature rise.	

Display message	F l u e t e m p h i g h 9 9 9 , 5 h r s
Reason	Flue gas temperature has exceeded the limit.

Cause:	
Heat exchanger polluted and not able to transfer enough heat to the system water.	
Corrective action:	
Check and clean heat exchanger.	

Cause:	
Bad flue gas sensor or sensor connection (partly shorted.)	
Corrective action:	
The sensor is of the type NTC. This means when the temperature rises, its resistance decreases. A partly shorted sensor will drop its resistance and therefore 'measure' a raise in temperature when actually there is none. Check for moist in the sensor connections or replace the sensor.	

Cause:
There is no water in the unit while firing.
Corrective action:
This situation is unlikely if all system checks have been performed properly prior to firing the boiler. Check the system and boiler for leaks and/or air in the system and bleed thoroughly. Ensure the boiler air vent has been opened and all air expelled from the heat exchanger.

Cause:
Heat exchanger failure.
Corrective action:
This is an unlikely situation but when there is severe damage to the heat exchanger, the combustion product will not be able to transfer all heat to the system water. The heat that is not transferred will convert to an increased flue gas temperature.

Display message	A n t i c y c l e t i m e
	9 9 9 , 5 h r s
Reason	The controller received a new heat demand too fast after the last ended demand.

Cause:
Opening and immediately thereafter closing of the external thermostat.
Corrective action:
Controlled water flow cools down too quickly after loss of heat demand. Controlled water flow heats up too quickly after start of heat demand. Immediately opening and closing of the external thermostat. Check switching differential of the ON/OFF thermostat. Controller settings need to be changed. Be aware that the standard settings work fine for all common systems. When anti-cycling is active, because of immediate heating or cooling of the controlled water flow/temperature, it concerns an unconventional system.

Display message	W a t e r p r e s s u r e f a u l t
	9 9 9 , 5 h r s
Reason	Water pressure is too low or high.

Cause:
The water pressure in the system is too high.
Corrective action:
Check if the system pressure is too high after (re)filling. Make sure that there is a pressure relief valve and expansion vessel installed in the system, according to the applicable standards. Check if there is an open connection between the unit and the relief valve plus expansion vessel. Be aware that if the unit is installed in the basement of a tall building, only the static pressure of the water column above the units can raise above the maximum allowable limits. Make sure that this is not the case.

Cause:
The water pressure in the system is too low.
Corrective action:
Check if there is no leakage in the system that causes the pressure to drop. Fix any leakage and fill the system. Check if there is an external system pump that sucks water through the boiler, causing an under pressure (bad installation design).

Display message	L i n e f a u l t																			
	p u m p o n							9	9	9	,	5			h	r	s			
Reason	Bad power supply																			

Cause:
The supplied power does not comply with the specifications.

Corrective action:
Check if the power supply is connected correctly to the unit.
Check the voltage and frequency (should be Life Neutral, Gnd > 230 Vac / 50 Hz).
Make sure there is no signal failing or voltage peaks in the power supply.

Display message	T 2 - T 1 h i g h																			
									9	9	9	,	5			h	r	s		
Reason	Difference between T2 and T1 has exceeded the blocking value which has been set in the parameters.(return temp higher than flow)																			

Cause:
The water flow through the unit is too low.

Corrective action:
Check functioning of the pump.
Check/open all valves that might restrict the water flow through the unit.
Check for an external system pump that influences the flow through the unit.
Check if the system resistance exceeds the spare capacity of the unit pump.
Make sure the heat exchanger is clean. Heat exchanger fouling (partly blockage) will increase the resistance causing the water flow to drop.

Display message	O u t d o o r s e n s o r f a i l																			
									9	9	9	,	5			h	r	s		
Reason	No outdoor sensor detected.																			

Cause:
The unit is programmed to check if an outdoor sensor is present and does not detect an outdoor sensor.

Corrective action:
Check for loose wiring/connections in the outdoor sensor circuit.
Check the state of the outdoor sensor and replace if necessary.

Display message	d T b l o c k																			
									9	9	9	,	5			h	r	s		
Reason	Temperature difference between flow and return has exceeded the blocking value, but not the lock out value.																			

Cause:
The water flow through the unit is too low.

Corrective action:
Check functioning of the pump.
Check/open all valves that might restrict the water flow through the unit.
Check for an external system pump that influences the flow through the unit.
Check if the system resistance exceeds the spare capacity of the unit pump.
Make sure the heat exchanger is clean. Heat exchanger fouling (partly blockage) will increase the resistance causing the water flow to drop.

18 MAINTENANCE

18.1 GENERAL

In the UK, it is the law that the boiler must be serviced by a competent engineer registered with an HSE approved body every 12 months, more regular maintenance may be required depending on load and operating conditions.



**Maintenance and inspection of the boiler should be carried out at the following occasions:
When a number of similar error codes and/or lock-outs appear.
At least every twelve months to ensure safe and efficient operation.
Damage caused by the lack of maintenance will not be covered under warranty**

18.2 MAINTENANCE REMINDER FUNCTION.

← See previous page.

BE AWARE: This function is off as standard. This function should be used as a reminder only and does not replace the requirements for regular checks by a competent engineer. Our units must be maintained every twelve months whatever the settings/working of this function.

It is and remains the responsibly of the end user to have the unit maintained every twelve months.

For more information about this maintenance mode see section 11.18, 'Setting the maintenance specifications', page 71.



Before starting any Service work on the boiler, the Maintenance set item number LE04000243 must be purchased from Lochinvar Ltd. This set contains many essential replacement gaskets and consumable parts required to carry out a full service of the Boiler.

18.3 SERVICE INTERVALS

The normal service frequency for the boiler is once a year. Every year the boiler should be cleaned and checked, according to the maintenance procedures. If there is doubt whether the boiler is operating with the correct water and/or combustion air quality, it is advised that a first check takes place after six months. This check serves to determine the frequency of the future services. The maximum interval between two services is a year.



It is a condition of the boiler warranty that the boiler must be serviced by a competent engineer registered with an HSE approved body every 12 months,

18.4 INSPECTION & MAINTENANCE

Inspection, maintenance and the replacement of boiler parts should only be done by a skilled service engineer. Apart from the maintenance proceedings it is advised to have a log chart for every boiler that describes the following aspects:

- Serial number
- Date and time of maintenance
- Name of maintenance engineer
- Which parts were exchanged during maintenance
- Which settings (software) were changed during maintenance
- Special remarks / findings
- Future aspects that need extra attention
- Additional aspects: measurement reports, complaints by the (end)-user, lock-out codes, etc.

During maintenance the following parts and aspects of the boiler should be checked and inspected.

NOTICE: Before starting to work on the boiler:

- Ensure you have item number LE04000243 Boiler maintenance set
- Switch off the electrical power to the boiler (service switch and/or unplug boiler)
- Close the gas valve to block gas supply to the boiler

18.4.1 Customer comments

Comments and remarks from the customer should be analysed and used to find possible causes for any occurring problems and complaints.

18.4.2 Service history

The operational and fault history (total amount and since the last service) of the boiler can be retrieved with the help of a computer, correct software and an interface cable. This information can be used to specify the maintenance and service proceedings in relation to the boiler (parts).

18.4.3 Water leakage

The water pressure of the heating installation should be more than 1.0 bar and at a maximum of 2.0 bar in normal operation. When the water pressure drops below the minimum occasionally, there might be a water leak. Check the boiler and the complete heating installation for any water leakages and have these repaired.

18.4.4 Flue gas & air supply

The flue gas pipes and the air supply pipes must be checked for gas tightness. Also check if the mounting of these pipes is correct, safe and not damaged. Check the rooftop of the boiler housing for signs of water leakage and traces of water coming from the air supply pipe, the air vent or any condensate coming from the flue gas pipes.

18.4.5 Gas supply

The gas pipes must be checked for gas tightness. Also check if the mounting of these pipes is correct, safe and not damaged. Any building specific safety features (such as a fire alarm link) should be checked for correct functioning.

18.4.6 Remove complete burner unit

The complete burner unit consists of the fan, the burner plate and the internal burner. To remove this part for an internal heat exchanger check: remove the six M6 nuts, the ignition cable and the thermal fuse cables. After this, take out the complete burner unit by moving it forward out of the boiler housing. NOTICE: Watch out not to damage the burner plate insulation during this operation. While removing the complete burner unplug both of the electrical and controlling cables of the fan. After all this dismantle the air gas mixing box on the suction side of the fan and check the blade wheel of the fan.

18.4.7 Burner

Check the burner surface to see if it has damages, signs of rust and/or cracks. When the burner surface is damaged the burner must be replaced. The burner can be cleaned by using a soft (non-metallic) brush. The dust can be removed with a vacuum cleaner or pressurized air.

18.4.8 Ignition / ionisation electrode

When the complete burner is removed, it is very easy to check the ignition electrode. First check if the distances between the electrodes and between the electrode and the burner are according to the graph below. When these are not correct, try to bend the electrodes in the right position. Notice: the electrodes undergo high temperatures, therefore the electrodes become hard and are difficult to bend. While bending used electrodes they might break or burst. Check the electrode, after bending, for any tear/crack and signs of rust. When they are burst/cracked or rusty, replace the electrode. Also replace the electrode when there is a crack in the ceramic insulation of the electrode. When the electrode is replaced, also the gasket should be renewed.

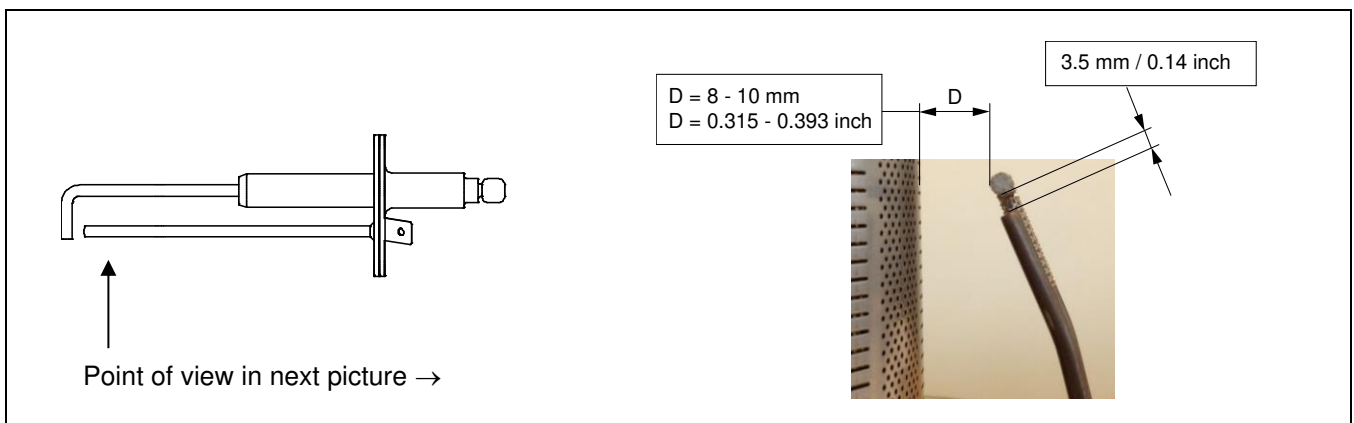

18.4.9 Burner door gaskets

If the gasket starts to change colour in sections, this indicated damage and the gasket must be replaced. Only use genuine Lochinvar parts.

18.4.10 Fan

When the fan blades are polluted and dirty, carefully clean the blades with a soft brush. Notice: do not use too much force on the blades or the fan might be out of balance and run irregularly, causing noise and fan failures. Check the fan also for any water damage. In doubt always replace the fan of the boiler.

18.4.11 Insulation

The heat exchanger insulation fitted to the side and rear walls of the heat exchanger should be inspected for any signs of damage at every service, if there is any damage (however minor) then this insulation should be replaced.

Only use genuine Lochinvar parts.

The same procedure must be applied on the insulation and gaskets fitted on the burner door.

18.4.12 Siphon

Disassemble the siphon and clean every part of it. Check the siphon connection of the heat exchanger for any blocking or pollution and clean it (if necessary). Check the functioning of the siphon by pouring clean tap water in the combustion chamber (when burner door is removed). This water will exit the heat exchanger by the siphon. Notice: don't wet the rear wall insulation.



When mounting the bottom part of the siphon, before commissioning the boiler and/or after maintenance, the siphon must ALWAYS be FILLED COMPLETELY with water.

This is a safety measure: the water in the siphon keeps the flue gases from leaking out of the heat exchanger via the condensate drain.

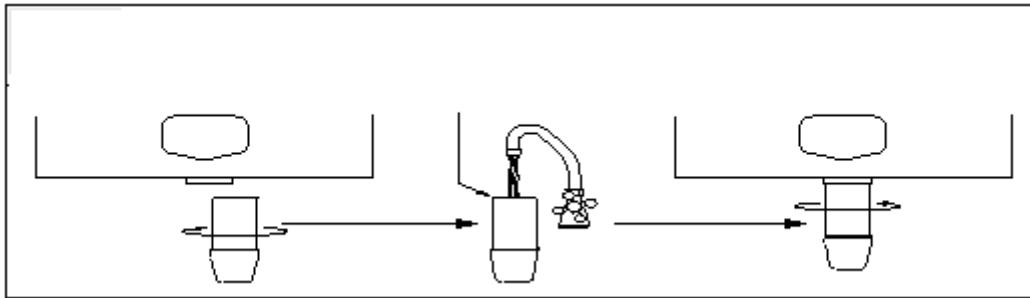

18.4.13 Heat exchanger and combustion chamber

After the removal of the complete burner unit check if there is any debris and dirt in the heat exchanger. The coils of the heat exchanger can be cleaned by using a **non-metallic** brush. After this the dirt and dust can be removed with a vacuum cleaner and by flushing the combustion chamber with water. Don't forget afterwards to clean the siphon once again.

18.4.14 Gas/air ratio

With every service check and/or maintenance of the boiler always check the gas/air ratio by measuring the CO₂ percentage (flue gas) at the maximum and minimum load of the boiler. If necessary adjust these values. See chapter 15 "Adjusting and setting the burner" for further information.

18.4.15 Pump

Check the electrical parts and the motor of the pump for correct functioning. The pump must generate a sufficient water flow over the (heat exchanger of) the boiler. When the pump produces noise, is operational for more than five years or has signs of water leakage it is recommended to replace the pump as a precaution.



When defects and abnormalities are found by the service engineer during service and maintenance and these are not repairable, this information should be reported to the owner/end-user of the installation. Also these defects should be reported in the service report / log file of the boiler.



During service and maintenance the gas, supply air, flue gas and condensate connections are disconnected, checked and replaced. Make sure that all these components are mounted correctly before commissioning the boiler again.



Cleaning the combustion chamber with acid or alkali products is prohibited.

18.4.16 Mounting the burner door correctly back onto the heat exchanger:



Before mounting the burner door, make sure that its gaskets and insulation are in excellent shape. If any signs of damage or ageing are present, these parts must be replaced.

The burner door must be mounted back on the heat exchanger as follows:

- Place the burner door with its holes over the six threaded studs.
Careful! When handling too rough or misplacing the holes over the threaded studs, the burner door insulation and/or gaskets can be damaged.
Assure yourself that the door is well positioned with respect to the threaded studs, before pushing it onto the exchanger.
- Now keep the burner door firmly in place by pushing the gas/air nose with one hand at the middle at point A.
- Then turn-tighten the flange nuts with the other hand as far as possible onto the threaded studs.

Now the burner door is in place and the nuts can be tightened with a torque key.

- Tighten the nuts in the order given in the picture
- The specified torque value for tightening the burner door flange nuts is **8 Nm**

Tighten in given order.

torque value = 8 Nm

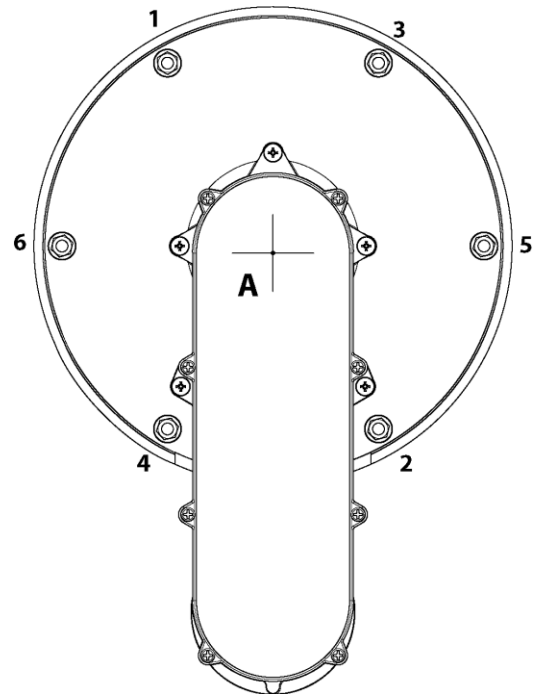

19 USER INSTRUCTIONS

After installing and commissioning of the boiler, demonstrate the operation of the entire central heating system to the end-user. The user should be made familiar with all safety precautions of the boiler and the installation. The user should be instructed that service and maintenance of the boiler is required every twelve months. Regular service and maintenance is essential for a safe and proper operation of the boiler. Hand over the documents supplied with the boiler.

20 ERP SPECIFICATION DATASHEET

Type Boiler:		CPM 58	CPM 77	CPM 96	CPM 116	CPM 144	CPM 175
Condensing boiler:		Yes	Yes	Yes	Yes	Yes	Yes
low temperature boiler:		Yes	Yes	Yes	Yes	Yes	Yes
B11 boiler:		No	No	No	No	No	No
Cogeneration space heater:		No	No	No	No	No	No
Combination heater:		No	No	No	No	No	No
	Unit:	Value	Value	Value	Value	Value	Value
Rated heat output	kW	53.5	72.1	89.4	107.7	132.9	159.9
P-rated (P4) at 58-77C	kW	53.5	72.1	89.4	107.7	132.9	159.9
Heat output (p1) 30% at 30-37C	kW	17.9	24.1	29.8	36	44.7	53.7
Seasonal space heating energy efficiency (η_s).	%	91.9	92.3	92.4	92.6	92.3	92.3
Energy efficiency (η_4) at 58-77C	%	86.8	87.4	87.4	87.4	86.8	86.8
Energy efficiency (η_1) at 30-37C	%	96.9	97.2	97.2	97.5	97.2	97.1
Auxiliary electricity consumption							
At full load (elmax).	kW	0.111	0.136	0.142	0.151	0.214	0.229
At part load (elmin)	kW	0.024	0.025	0.025	0.032	0.041	0.041
In standby mode (Psb)	kW	0.004	0.004	0.004	0.004	0.004	0.004
Other							
Standby heat loss (Pstby)	kW	0.063	0.067	0.071	0.076	0.084	0.094
Ignition burner power consumption	kW	0	0	0	0	0	0
Annual Energy Consumption	Gj	112	-	-	-	-	-
Emissions (Nox) of nitrogen oxides (EN15502)	mg/kWh	38	46	40	45	41	44
Sound power level, indoors (EN 14436-1:2006)	dB	65	67	65	62	66	69

21 INDEX

- 0-10 vdc remote burner input control, 89
- 0-10 vdc remote flow temperature set point, 89
- 3-way valve (diverter valve), 6, 48, 91

- accessories and unpacking, 8
- adjusting and setting the burner, 101
- air separator, 19 ff.
- air supply, 11, 25
- air venting, 16, 17
- CPM 58-116, 8
- CPM 144-175, 9
- anti-Legionnaires' disease (pasteurisation) function, 93
- automatic air vent, 17

- blocking, 15, 48, 82, 88, 98, 113, 124
- boiler connections, **Error!**
Bookmark not defined.
- boiler room, 11
- by-pass, 14

- checking the fault history, 70
- checking the operating history, 69
- cleaning of the burner, 124
- closed boiler, 11, 25
- commissioning the boiler, 95
- connections electric, 48 ff.
- connections gases miscellaneous, 22 ff.
- connections water miscellaneous, 12 ff.
- control panel / display unit, 53
- control panel menu structure, 54
- controlling behaviour settings, 88
- controlling options and settings, 86

- dimensions, 8
- dirt filter, 19 ff.
- dirt separator, 19 ff.
- display during operation, 56
- diverter valve (3-way valve), 6, 48, 91

- efficiency, 6
- electrical connections, 48
- electrical installation, 48
- electrical schematics, 50
- extra boiler control, 86

- fan, 11, 59, 86, 112, 124
- fault checking, 70, 82
- fault codes display, 82
- fault codes. blocking codes, 113
- firing for the first time, 100
- flue gas and air supply systems, 22
- flushing with clean water, 18
- frame, 12
- frost protection, 15

- gas conversion, 109
101 ff, 112, 124

- hanging level, 12
- heat exchanger, 6, 91 ff, 124

- heating, 86 ff.
- heating and hot water switching at sudden temperature drop, 93
- heating and hot water switching time, 93
- hydraulic graphs, 20
- hysteresis, 88

- ignition, 124
- indirect hot water / Indirect DHW Cylinder, 91
- inspection & maintenance, 124
- installation of the CPM 11
- installing a strainer and/or dirt separator, 15
- introduction, 6

- legionnaires' disease, 62, 93
- low loss header, 14, 19, 98
- low/high flow temperature to tank coil, 91
- low-water level protection, 11
- Ls and Lw gases, 101 ff, 107

- maintenance, 124
- max cooling time, 86
ff.
- monitor screens, 57

- 90

- offset, 88
- outdoor sensor (outdoor oxygen, 16 ff.
oxygen diffusion proof, 98
oxygen tight, 98

- password, 75
- plastic piping in the heating system, 16
- positioning the boiler, 12
- power (supply), 6, 15, 48, 98
- pressure relief valve, 14
- pressure safety valve, 98
- printed circuit board, 50
- pump, 15
- pump and 3-way valve control, 91
- putting the boiler out of operation, 112

- quality of used water, 16

- reset, 82
- room thermostat on/off, 89
- room thermostat open therm, 89

- safety guidelines, 5
- service function, 59
- set points, 61
- setting at the maximum load, 101 ff.
- setting at the minimum load, 101 ff.
- setting the maintenance specifications, 71
- setting the parameters with the display menu, 75
- setting the time & date, 60
- setting the timer programs, 62
- starting the boiler, 100

- stationing the boiler, 12
- status, 56

- tank sensor, 91
- tank thermostat, 91
- technical data CPMboilers, 6
- temperature display on/off, 86
- timer contact function, 90

- unpacking, 11
- user instructions, 128
- user manual, 6, 11

- valve, 100 ff, 101 ff, 124
- ventilate, 5, 11
- venting, 5, 11, 16, 17, 124

- wall mounted duct, 12, 19
- water pressure, 18
- water pressure switch, 48, 98
- water quality, 16
- water side connections, 12
- water treatment, 18



IMPORTANT INFORMATION

These instructions must be read and understood before installing, commissioning, operating or maintaining the equipment.

