

Correx® Power Anode Installation, Commissioning and Maintenance Instructions

MODELS:

LST66 - 220

SIVS66 - 220

SIVT66 - 220



Contents

1.0	GENERAL	3
2.0	OPERATION	3
3.0	COMPONENTS.....	3
4.0	INSTALLING THE CORREX® POWER ANODE	4
4.1	INSTALLING THE Ti-ANODE	5
4.2	INSTALLING THE CORREX® POWER ANODE BOX	5
4.3	CONNECTING MAINS POWER	7
4.4	BMS CONNECTIONS	7
4.5	SWITCHING ON THE CORREX® POWER ANODE	8
4.6	MAINTENANCE	8
4.7	FAULT FINDING	9
4.8	WIRING DIAGRAM	10

1.0 GENERAL

THESE INSTRUCTIONS ARE FOR USE WITH PART NUMBER LV310545 ONLY.

The Correx® power anode protection system is designed to protect the inner surface of the LST range of direct storage vessels and Squire range of indirect water heaters. The Correx® system replaces the standard magnesium sacrificial anodes.

Due to the fact the Correx® Ti-Anodes are non-sacrificial, maintenance costs are reduced. Anode inspection/replacement is no longer required. The only check required is to ensure a green LED is illuminated on the Correx® front cover.

2.0 OPERATION

The Correx® system operates on a 230V 1ph 50Hz electrical supply and has a 10V output to a titanium anode (Ti-Anode). A small current is passed from the potentiostat and emitted from the Ti-Anode to the inner surface of the storage vessel, neutralising the naturally occurring electrolytic action of the stored water.

3.0 COMPONENTS

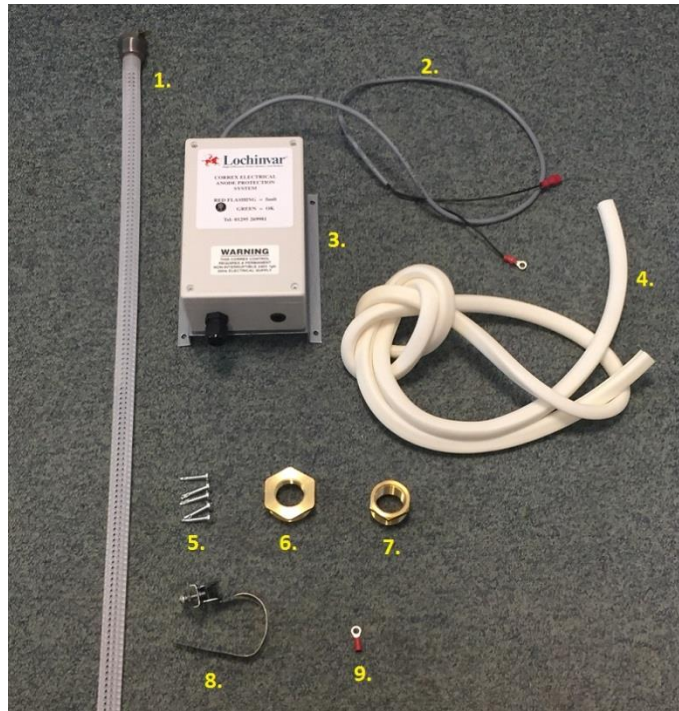

Item No.	Description	Comments
1	Ti-Anode with plastic cover	Titanium Anode
2	Correx® Cable	
3	Correx® Power Anode Box	
4	Lid Seal	Not Required For Models : LST, SIV or SIVT - DISCARD
5	Fixing Screws	Depending on the fixing surface, alternative fixings may be required
6	1 ¼" to ¾" Bush	Required for models LST 66-220, SIVS 100-220 & SIVT 100-220
7	1" to ¾" Bush	Required for models SIVS 66 & SIVT 66
8	Cathode Bonding Strap	For securing cathode connection to tank body
9	Eyelet Crimp Connection	

4.0 INSTALLING THE CORREX® POWER ANODE

The method for installing the Correx® power anode is the same for all models, the only difference being the SIVS 66 and SIVT 66 use a 1" to 3/4" bush to fit the Ti-Anode.

4.1 TOOLS REQUIRED

- 32 mm socket and drive bar (required for removing anode) - models LST 66-220, SIVS 100-220 & SIVT 100-220)
- 27 mm socket and drive bar (required for removing anode) - models SIVS 66 & SIVT 66
- 42 mm socket for fitting 1 1/4" bush (Item No.6) - models LST 66-220, SIVS100-220 & SIVT 100-220
- 34 mm socket for fitting 1" bush (Item No.7) - models SIVS 66 & SIVT 66
- Battery drill
- 10 mm drill Bit
- Cable cutters
- Spade crimping tool
- Standard Philips screwdriver
- Small Philips screwdriver
- Thread sealant

NOTE - An impact wrench may be required to remove the magnesium anodes – if using such a tool the appropriate PPE must be worn.



Drain the storage vessel before attempting to remove the anode.



Let the vessel cool down before draining and removing the anode. Hot water can cause severe burns.

4.2 INSTALLING THE Ti-ANODE

Refer to photographs found on pages 3 and 5 for additional guidance.

- Layout components found in the Correx® - discard item 4 as this is not required when fitting the Correx® power anode to our range of vessels.
- Remove the lid from the vessel.
- Remove the top layer of vessel insulation.
- Locate the sacrificial magnesium anode.
- Remove the sacrificial magnesium anode.
- For models LST 66-220, SIVS 100-220 and SIVT 100-220 fit the 1 ¼" to ¾" bush to the tapping previously occupied by the magnesium anode - use sealant on the thread. (Item No. 6).
- For models SIVS 66 and SIVT66 fit the 1" to ¾" bush to the tapping previously occupied by the magnesium anode - use sealant on the thread. (Item No. 7).
- Fit the Ti-Anode with plastic cover (item No.1) into the relevant bush. **Do not** use sealant as the anode is fitted with an O-ring.

4.3 INSTALLING THE CORREX® POWER ANODE BOX

- Mount the Correx® Power Anode Box (Item No.3) to a wall adjacent to the appliance – if the Correx® Cable is too short then mount on a unistrut frame adjacent to the vessel. Use the supplied screws (item No.5) to mount the box. Depending on the mounting surface additional fixings may be required.
- Drill a 10 mm hole into the side of the insulation, approx. 60 mm from the top of the insulation. **See photo 1 on page 6.**
- Feed the Correx® Cable (item No.2) through the 10 mm hole and into the lid area of the vessel. The cable has two wires, one wire has a spade connector fitted to the end and this fits to the Ti-Anode. The other wire has an eyelet terminal and this fits to the cathode connection.
- Connect the Ti-anode spade connection onto the Ti-anode.
- Fit the cathode bonding strap (item No.8) to one of the lifting rings on top of the vessel. **See photo 2 on page 6.**
- Replace the existing ring terminal with the larger ring terminal supplied in the kit (item No.9). **See photo 3 on page 6.**
- Fit the cathode connection (eyelet terminal) to the cathode bonding strap and tighten.
- The installation should now look similar to **photo 4 on page 6.**
- Remove the front cover from the Correx® power anode Box (Item No.3).
- Conduct a continuity check from the potentiostat to the Ti-anode and from the Potentiostat to the cathode bonding strap and tank body to ensure sound connections. You may need to remove the spade connectors on the potentiostat to do this. **See photo 5 on page 6.**
- Replace front cover.

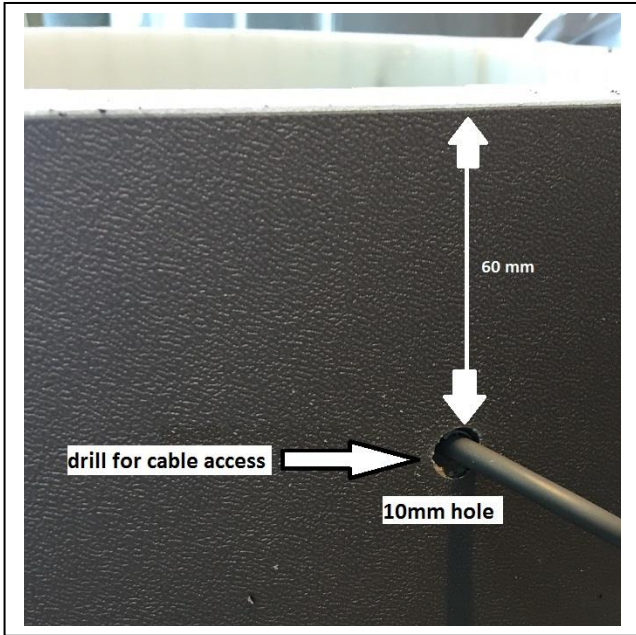

PHOTO 1

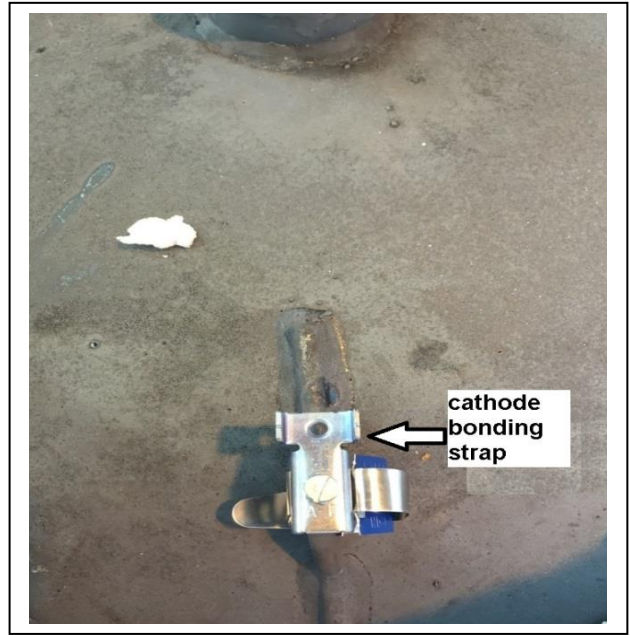

PHOTO 2

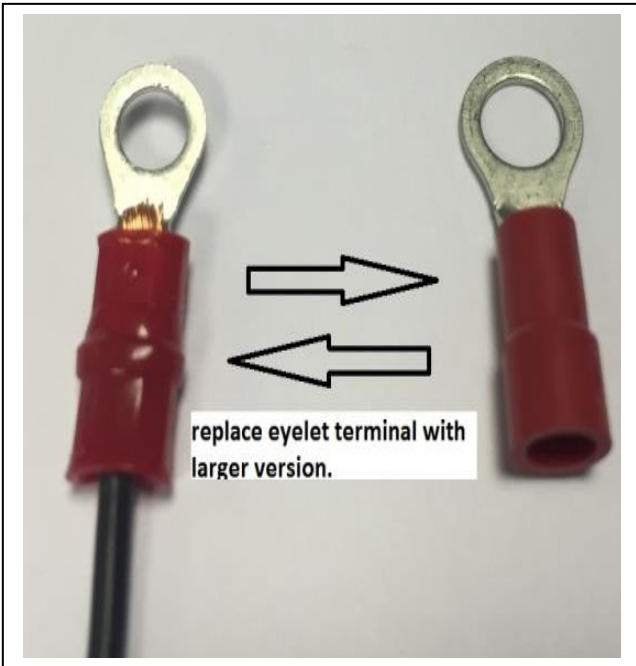

PHOTO 3

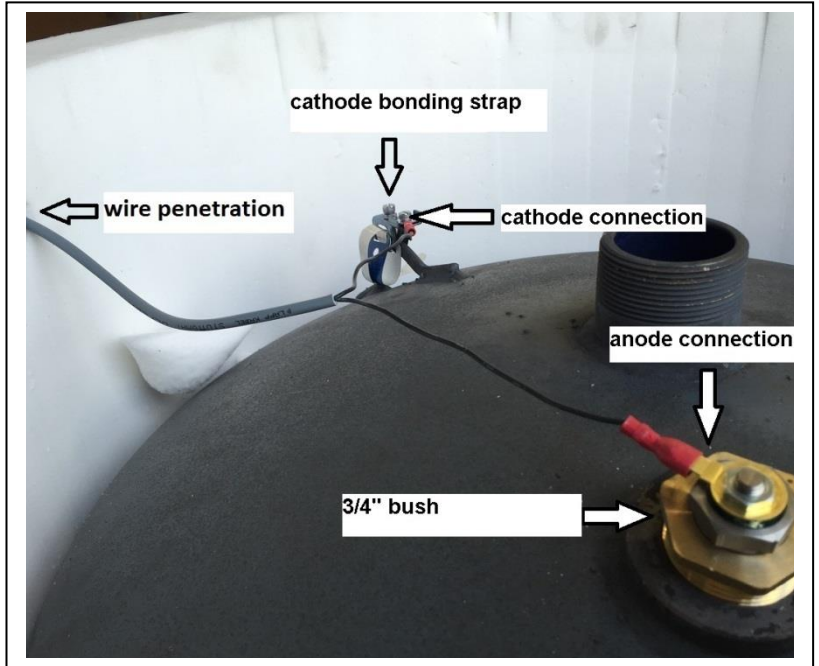

PHOTO 4

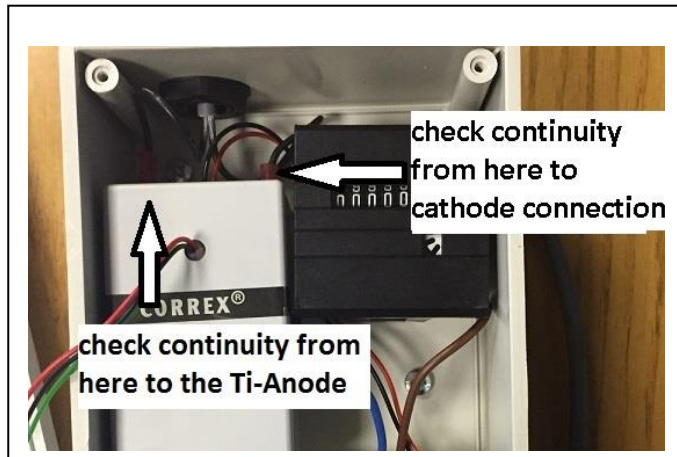
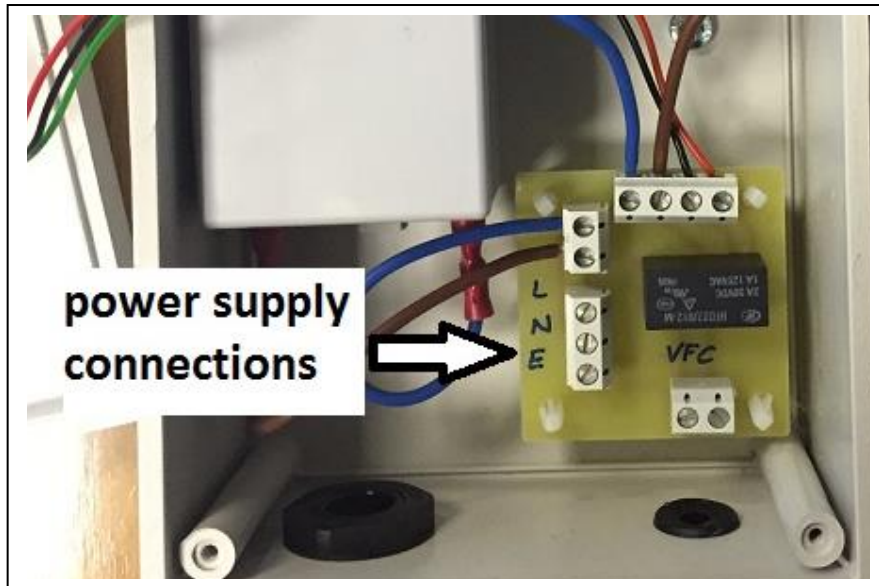

PHOTO 5

4.4 CONNECTING MAINS POWER

- Connect the Live phase to position L on the connection strip.
- Connect Neutral to position N on the connection strip.
- Connect Earth to position E on the connection strip.



4.5 BMS CONNECTIONS

The Correx® unit is supplied with a volt free relay – this relay is normally open and will close in the event of a failure on the unit. See wiring diagram on page 9.

Note – Faults such as loss of power will not be indicated. Regular checks should be made on the unit to ensure a solid green LED is indicated on the front of the unit see 4.6 Maintenance.



4.6 SWITCHING ON THE CORREX® POWER ANODE

- Refill the vessel.
- Check for leaks around the Ti-anode connection.
- Re-check all wiring.
- Switch on the unit.
- Ensure a solid green LED is showing on the front of the unit (check again after 5 minutes as a fault on the circuit may not show immediately).

5.0 MAINTENANCE

- Check a solid green LED is showing on the front of the unit, this indicates the unit is working correctly. If a BMS connection is made to the unit (see **section 4.4**) it is still recommended to check the LED.
- Remove the front cover and check the hours run meter is correct for the length of time the unit has been installed.
- If a solid green LED is present then no maintenance is required during annual maintenance of the vessel.
- If anything other than a solid green LED is showing then refer to **section 5.1 Fault Finding**.

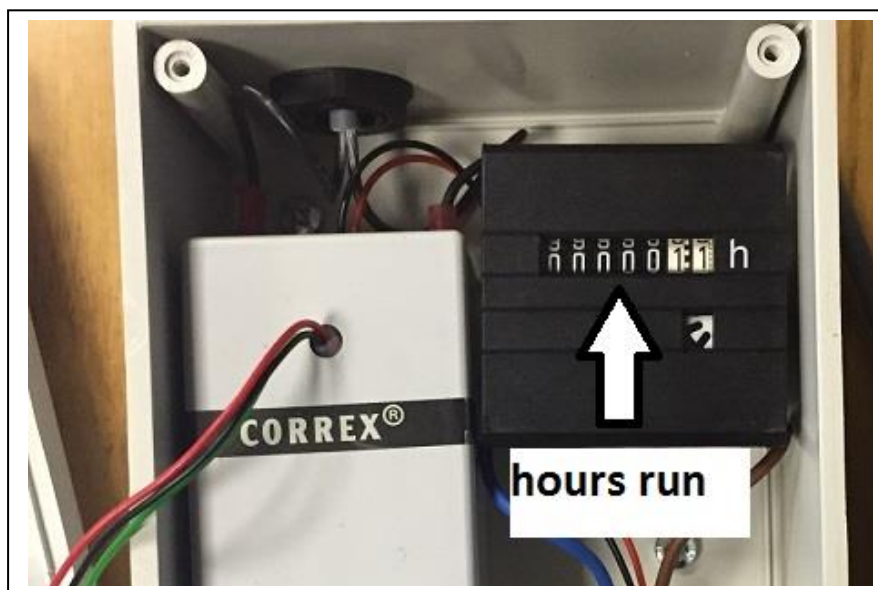

5.1 FAULT FINDING

Under normal operation the unit will display a solid green LED. If the unit is in fault it will either show a flashing red LED or no LED at all. Use the below chart for possible causes.

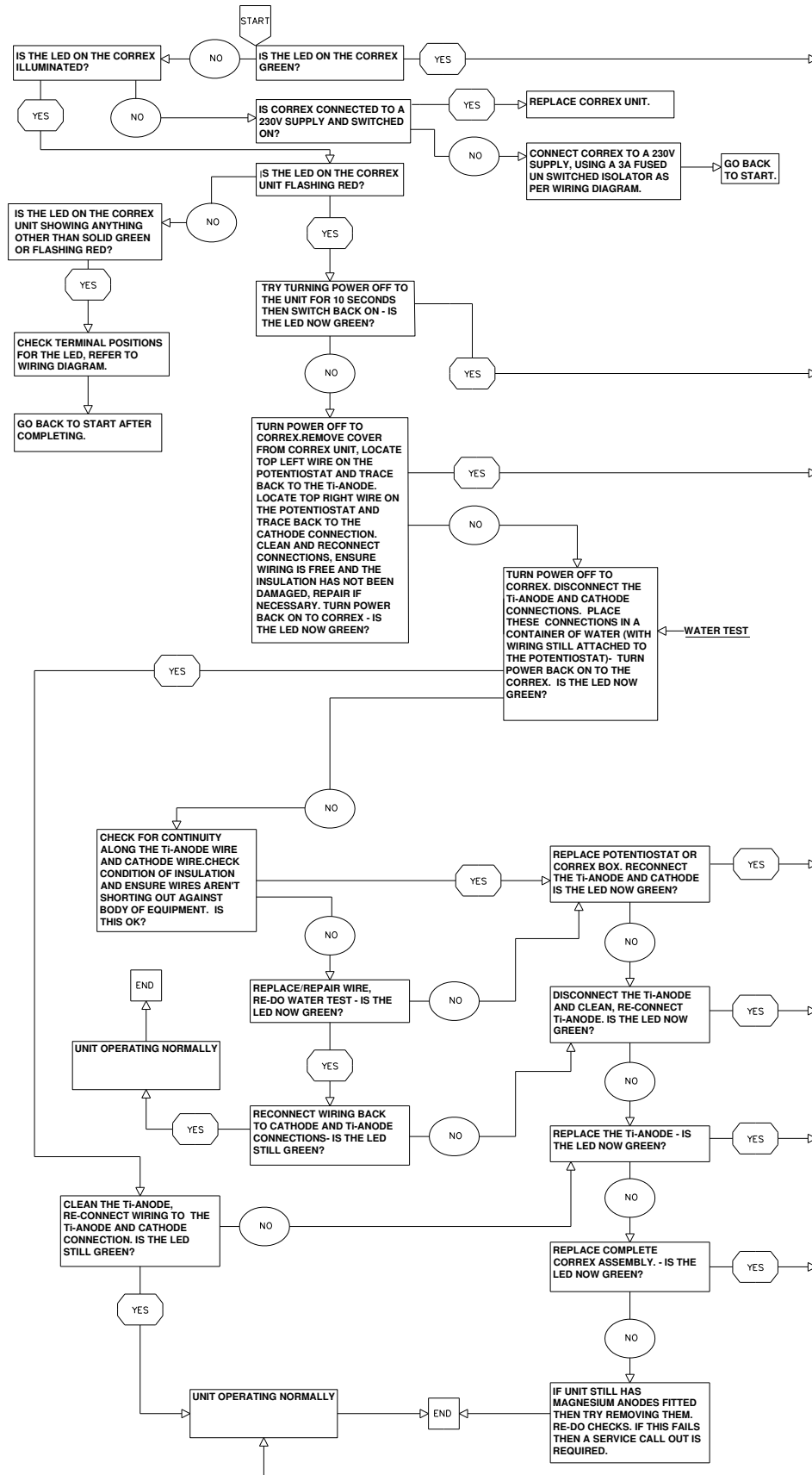

5.2 WIRING DIAGRAM

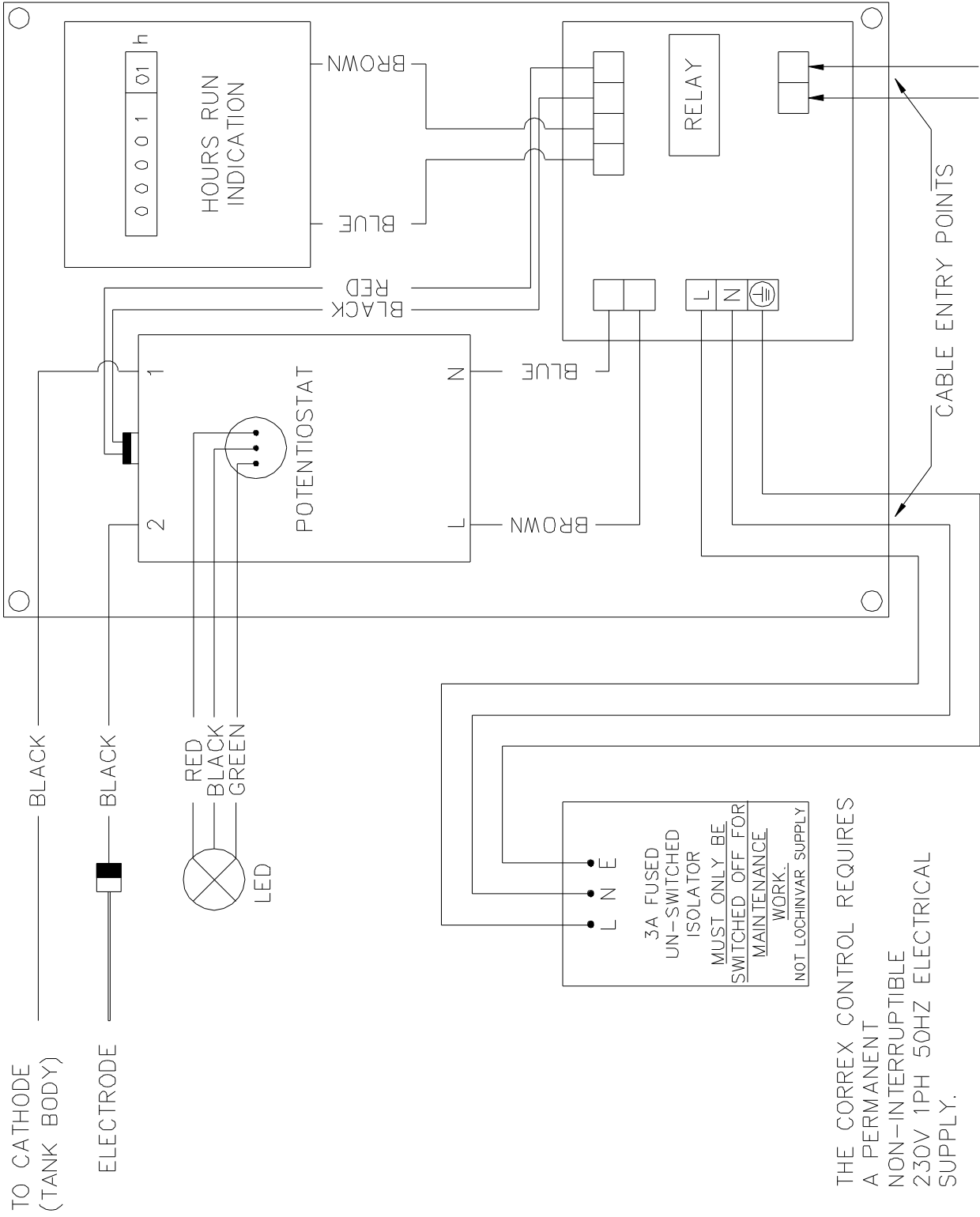

VOLT FREE CONTACTS
(WILL CLOSE IN A FAULT CONDITION)



IMPORTANT INFORMATION

These instructions must be read and understood before installing, commissioning, operating or maintaining the equipment.

