

IMPERIUM CONTROLLER

Installation, User and Service Manual

Model:
IMP LAHP 01



0338649 R0.0 / 1326 - Changes Reserved





IMPORTANT INFORMATION

These instructions must be read and understood before installing, commissioning, operating or maintaining the equipment.

Preface

Copyright

Copyright © 2026 Lochinvar Ltd.
All rights reserved.

Nothing from this publication may be copied, reproduced and/or published by means of printing, photocopying or by whatsoever means, without the prior written approval of Lochinvar Ltd.

Lochinvar Ltd. reserves the right to modify specifications in this manual.

Trademarks

Brand names in this manual are registered trademarks of their respective owners.

Warranty

Refer to the [appendix A.4](#) for the warranty provisions.

Liability

User

Lochinvar accepts no liability when the Imperium System Controller is not used correctly and requires

the user to:

- read this manual carefully and obey the instructions.;
- ask your installer for advice about the use of the controller;
- make sure that the service and maintenance activities are done by a qualified engineer.

Installer

Lochinvar accepts no liability when the Imperium System Controller is not used correctly and requires

the installer to:

- read this manual carefully and obey the instructions;
- explain the correct use to the user;
- make sure that you hand over all applicable manuals to the user.

Supplier

The Imperium Controller has been designed in accordance with the applicable regulations. The controller is supplied with a conformity mark and all necessary documentation to comply with these regulations. See the Conformity section.

Lochinvar Ltd. accepts no liability for claims from third parties if:

- the instructions for the correct installation of the controller are not followed;
- the instructions for the correct use of the controller are not followed;

Please refer to the Terms and Conditions for further information. These are available on request.

We believe that this manual provides you with accurate and complete descriptions of all relevant components. If you, nonetheless find errors or inaccuracies in this manual, please inform Lochinvar. This helps us to further improve our documentation.

Compliance

To ensure safe use of the Imperium System Control, the design complies with:

- the European Directive 2014/35/EU on low voltage appliances (LVD)
- the European Directives 2011/65/EU and 2015/863/EU on RoHS II and RoHS III

Please refer to the appendix [declaration of conformity](#).

As installer, maintenance engineer or user, you have to make sure that the entire installation complies with the local:

Regulations

- regulations applicable to building constructions;
- directives for existing electrical installations, supplied by your energy supplier;
- directives for (electrical) installations and related practice guidelines;
- directives that are supplied by the fire brigade, power companies and the municipality.

The installation must comply with the installation requirements of the manufacturer.



Warning

The installation must be carried out in accordance with the general and locally applicable regulations of water supply companies, electricity companies and the fire brigade, by a certified installer.

The installation area must be frost-free or protected against frost. The environmental conditions as specified in section [4.2](#) must be observed in order to guarantee the functioning of the electronics used.



Note

All regulations, requirements and guidelines may have been supplemented and/or amended at the time of installation.

Contact information

In the event of problems with the Imperium Controller or when you have any comments or questions, please contact your supplier.

Information about this manual

Content

This manual provides information on the safe and correct use of the Imperium System Controller and how to install and maintain it properly. The instructions in this manual must be followed.



Caution

Please read this manual carefully before switching on the controller. Failure to read the manual and/or follow the instructions may result in personal injury and damage to the controller.

This manual:

- describes how the controller works;
- describes the installation and maintenance of the controller.

Target group

The information in this manual applies to two target groups:

- installers;
- service- maintenance engineers.

Notation conventions

This manual uses the following text conventions:

- Numbers between parentheses e.g. (1), refer to elements in a figure that are described by the text;
- Cross-references to sections, tables, figures etc. are underlined and written as (see "...")

This manual contains the following text styles/symbols for situations that may endanger users/engineers, cause damage to equipment or need special attention:



Note

A note gives more information on a topic.



Caution

Obey the caution instructions to prevent damage of the de controller.



Warning

Obey the warning instructions to prevent danger of personal injury, and serious damage to the controller.

Document identification

Article number	Language	Version
0338649	EN	0.0

Table of Contents

Preface	1
Contact information	2
Information about this manual	3
Table of Contents	4
1 Introduction	6
1.1 About the Imperium System Controller	6
1.2 Supported heat pumps	7
1.3 List of abbreviations	7
2 Safety	8
3 Operation	9
3.1 System operation	9
3.2 CC01: The combi-cascade	11
3.3 CC02: The CH-cascade	12
3.4 The CH-system	13
3.4.1 Temperature control CH-system	13
3.4.2 CH-system control	13
3.4.3 CH back-up heaters	13
3.5 The DHW system	14
3.5.1 Multi-pass heating mode	14
3.5.2 One-pass heating mode	15
3.5.3 Switching system one-pass and multi-pass	17
3.5.4 Booster heating with electric elements	18
3.5.5 Temperature control of the DHW system	18
3.5.6 DHW system control	20
3.5.7 DHW back-up elements	20
4 Installation	21
4.1 Introduction	21
4.2 Ambient conditions	21
4.3 Mechanical installation	21
4.3.1 Mounting instructions	21
4.3.2 Dimensions	21
4.4 Electrical connections	22
4.4.1 Terminal blocks	23
4.4.2 Heat pump Modbus connections	26
5 Control panel	27
5.1 Most used symbols	27
5.2 Configuration screen	29
5.3 Main screen	31
5.4 Information screens	32
5.4.1 DHW system information	33
5.4.2 Central heating system information	34

5.4.3	Information about plate heat exchanger and transfer loop components	35
5.4.4	Heat pump information	36
5.5	Settings	37
5.5.1	Domestic hot water setpoint settings screen	38
5.5.2	ECO mode (week program).....	39
5.5.3	Configuration analogue inputs	41
5.5.4	Modbus settings.....	42
5.5.5	Central heating setpoint settings screen	43
5.6	Alarm messages	44
6	Troubleshooting.....	45
A	Appendix.....	46
A.1	Modbus register list.....	46
A.2	Electrical scheme.....	50
A.3	Declaration of conformity.....	51
A.4	Warranty	52

1 Introduction

1.1 About the Imperium System Controller

The Imperium System Controller is a customized system controller that acts as a link between the heat pump system, storage tanks and buffer tanks. This heating system can consist of a domestic hot water section, a central heating section or a combination of both.

System control

Thanks to the combination of intelligent system control, which controls sensors, valves, pumps and heat pumps, and Lochinvar's many years of experience in the field of hot water systems, the installation can be used optimally without compromising on comfort.

In addition, this system control offers the possibility to connect to both the internet and the building management system (BMS). This allows the user to remotely view and monitor the most important data from the heat pump and heating system. The connection to the building management system also makes it possible to control the system externally.

Finally, this system control has a graphical interface that makes it easy to adjust parameters. In addition, the most important system data, such as tank temperatures, valve positions and pump control, are visible at a glance.

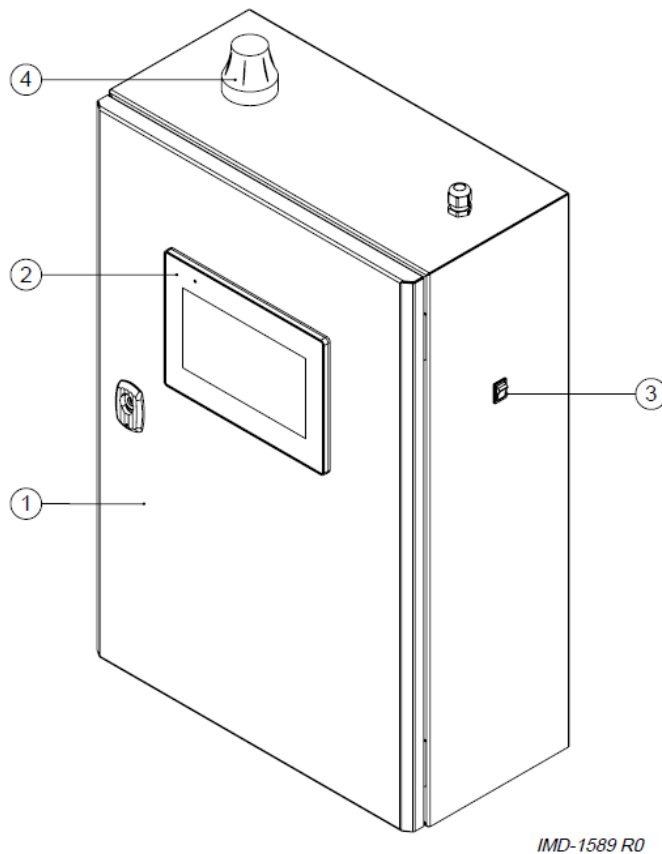

1 = Cabinet
2 = Display

3 = On/off switch
4 = Antenna

1.2 Supported heat pumps

The Imperium control is only suitable in combination with the following heat pump products from Lochinvar:

Type	Series	Products	ID-code
Air-source heat pump	Amicus Altus	LAHP 88	Altus 88
		LAHP 112	Altus 112

1.3 List of abbreviations

Abbreviation	Description
AH	Booster heating
AI	Analogue input
AL	Alarm condition
AO	Analogue output
BH	Back-up heating
BMS	Building management system
BTxx	Buffer tank
CCxx	Cascade
CH	Central heating
CL	Circulation loop
CPxx	Circulating pump
CVxx	Changeover valve
CW	Cold water
DGxx	Degasser
DHW	Domestic hot water
DI	Digital input
DO	Digital output
FTxx	Flow transmitter
HE	Heat exchanger
HPxx	Heat pump
HYS	Hysteresis
MAX	Maximum value
MIN	Minimum value
MP	Circulating heating (Multi-pass)
NRV	Non-return valve
OP	Direct heating (One-pass)
PI	PI controller
PTxx	Pressure transmitter
RVxx	Regulating valve
SP	Setpoint
STxx	Storage tank
TLxx	Transfer loop
TSxx	Temperature sensor

2 Safety

Lochinvar cannot be held responsible for damages or injuries which can be lead back to:

- Failure to follow the instructions provided in this manual;
- Carelessness during the installation, commissioning, use or maintenance of the Imperium System Controller.

Every user must study the user part of this manual and must follow the instructions in this part of the manual strictly. Do not change the sequence of the described actions.



Warning

If you detect a burning smell:

- Shut off the main power supply;
 - Alert the emergency services.
-



Warning

The installation must be carried out by an approved installer in compliance with the general and local regulations imposed by the water and power supply companies and the fire brigade.



Warning

Live parts present!

Disconnect the control system completely from the power supply before opening the outside door to access the electrical components.



Warning

External voltage present!

Some terminals are connected to an external voltage and are not isolated by switching the On/Off switch to position 0.



Caution

The installation, commissioning and maintenance may only be carried out by a qualified engineer.



Caution

This controller is not intended for use by persons with reduced physical, sensory or mental capacities, or who lack the necessary experience or knowledge, unless the person responsible for their safety is supervising them or has explained to them how the controller should be used.



Caution

This controller is not intended to be used by children under the age of 16. Always supervise children, and make sure that they do not play with the controller.



Caution

This controller does not fulfill any safety functions. The safety (temperature and pressure) of the installation must be covered in the applied system components such as the heat pump, electrical element and circulating pumps.

The pressure safety devices must be provided separately and are the responsibility of the installer.



Caution

This controller does not provide frost protection for the installation (including pipes and appendages). Frost protection is the responsibility of the end user and/or installer.

3 Operation

3.1 System operation

The Imperium controller is part of your complete Lochinvar hot water system. This complete system consists of the controller, Domestic hot water and buffer tanks, heat pump(s), circulation pumps and changeover and control valves. This complete heating system can be designed for DHW preparation, supplying hot water for your central heating system or a combination of both systems.

Cascade system

The heat pumps are divided into one or two different cascades. The first cascade (CC01) can be a combi system, which means that the heat pumps can be used both for domestic hot water preparation and for supplying hot water to your central heating system. The second cascade (CC02) is specifically for supplying hot water to the central heating system. An overview of the various components of the Imperium controller controlled system can be seen in [figure 1](#) below. The various components and their functions are described individually later in this chapter.

The following system combinations are possible:

System combinations



CC01

CC02

System letter	No. Buffer tanks [BT0x]	No. Heat pumps in DHW or Combi cascade	No. Heat pumps in an Additional CH cascade
A	-	1-3	-
B	1	1-3	-
C	1	1-3	1-7
D	2	1-3	-
E	2	1-3	1-7
F	1	-	1-7
G	2	-	1-7

For more information, see: [Figure 11](#)

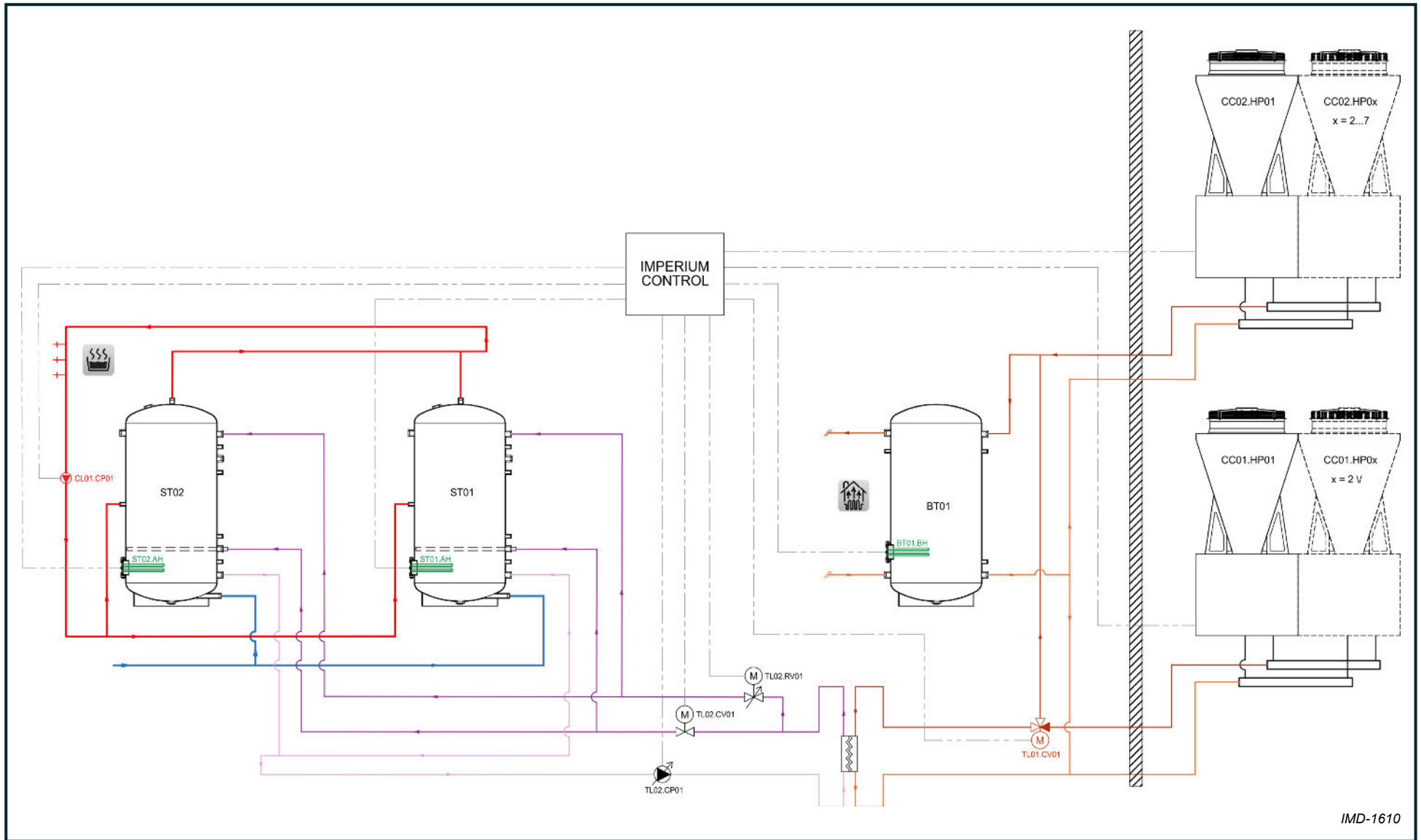

Figure 1 Overview of a hot water system controlled by the Imperium controller

3.2 CC01: The combi-cascade

The combi cascade can contain a maximum of three heat pumps. This cascade is indicated on the installation drawings with the code CC01. This combi cascade can be used for both hot water preparation and a combination of DHW and CH. Switching between DHW and central heating mode is done by switching a three-way valve (TL01.CV01) in the pipe from the heat pump cascade.

The system detects whether there is a heat demand from the DHW system or from the CH system and will switch components on or off when the heat demand changes. Heat pumps are switched on based on the operating time of the heat pump. The heat pump with the shortest operating time will be switched on first. The Imperium controller also considers the possible 'defrosting' of a heat pump in the cascade. When there is demand from both system components, the Imperium controller will give priority to the preparation of DHW.

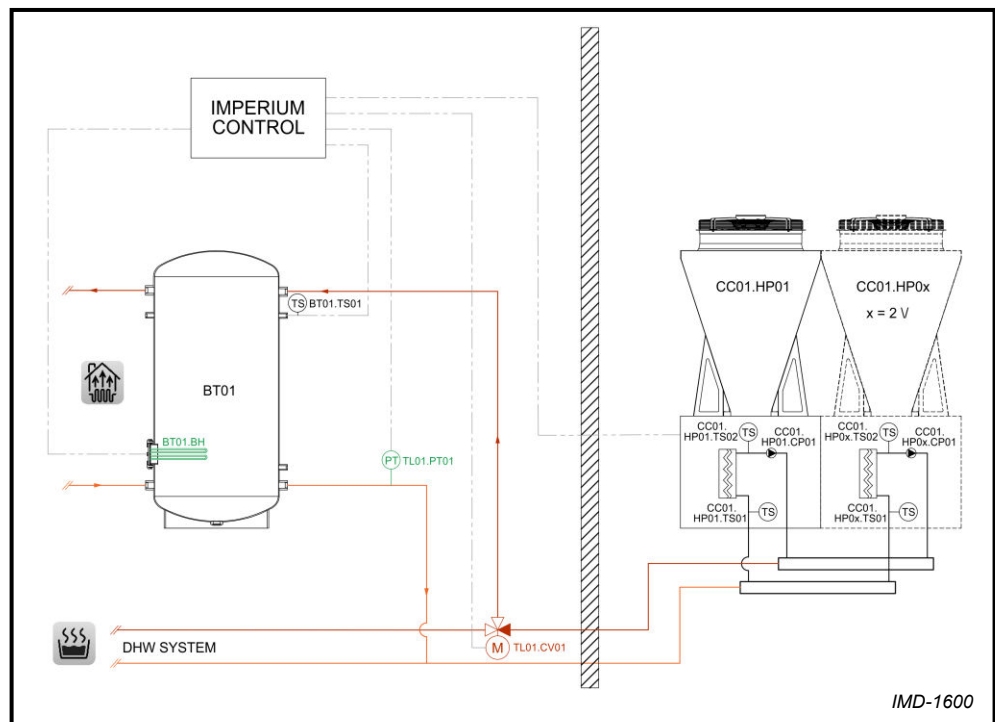

Figure 2 Combi-cascade system containing the most important system components

This includes the following components:

- CC01.HP0x** Heat pump, where x stands for the heat pump number (max. 3)
- CC01.HP0x.TS01** Temperature sensor for incoming temperature DHW system
- CC01.HP0x.TS02** Temperature sensor for outgoing temperature DHW system
- CC01.HP0x.CP01** Internal circulating pump heat pump
- TL01.CV01** Changeover valve DHW or CH
- TL01.PT01** Pressure transmitter (*optional*)
- BT01** Buffer tank 1 (*max. 2*)
- BT01.TS01** Temperature sensor buffer tank 1
- BT01.BH** CH Back-up element (*optional*)

3.3 CC02: The CH-cascade

The CH-cascade contains a maximum of seven heat pumps and, unlike the combi-cascade, can only be used for the CH system. This cascade is indicated on installation drawings with CC02. In combination with the CC01 combi-cascade, the CC02 CH-cascade provides additional heat pump capacity for the central heating system. This also makes it possible to heat the DHW system and central heating system simultaneously.

When the Imperium control receives a signal that there is a demand for central heating, the buffer tank will be heated to the setpoint temperature and, depending on the demand, more heat pumps will be switched on or off. Heat pumps are switched on based on their operating time. The heat pump with the shortest operating time will be switched on first. The heat pump that is switched on first will be switched off first. The Imperium controller also considers the possible 'defrosting' of a heat pump in the cascade. An overview of the second cascade and a central heating system is shown below.

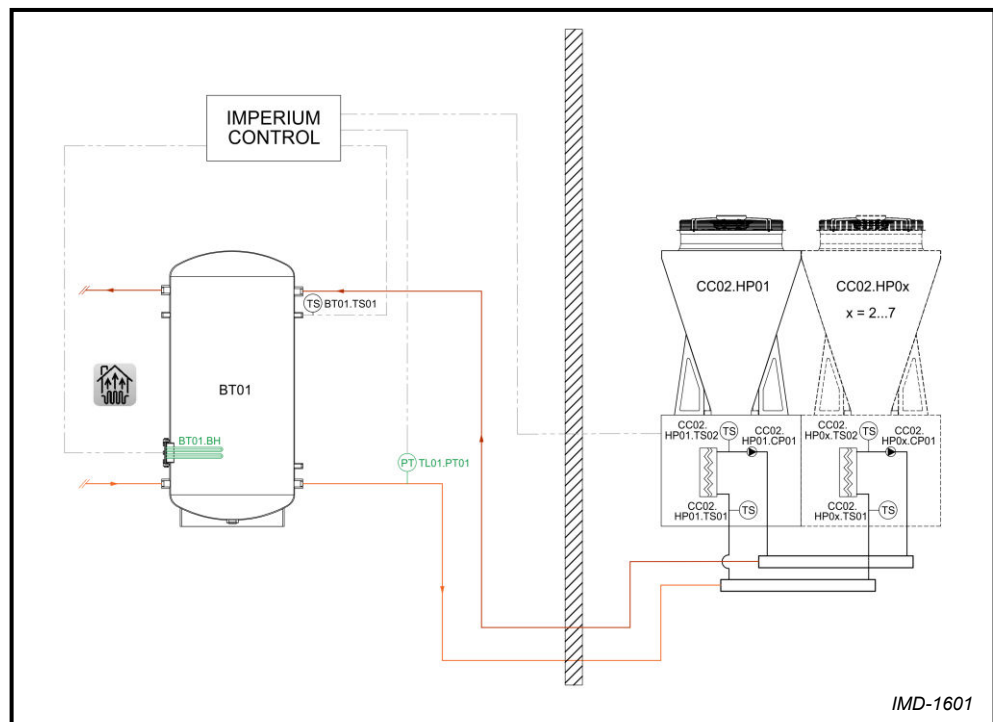

Figure 3 CH-cascade system containing the most important components

This includes the following components:

- CC02.HP0x** Heat pump, where x stands for the heat pump number (max. 7)
- CC02.HP0x.TS01** Temperature sensor for incoming temperature DHW system
- CC02.HP0x.TS02** Temperature sensor for outgoing temperature DHW system
- CC02.HP0x.CP01** Internal circulating pump heat pump
- TL01.PT01** Pressure transmitter (*optional*)
- BT01** Buffer tank 1 (*max. 2 buffer tanks*)
- BT01.TS01** Temperature sensor buffer tank 1
- BT01.BH** CH Back-up element (*optional*)

3.4 The CH-system

The central heating system consists of one or two buffer tanks. The central heating system is activated by heat demand from an (on/off) room thermostat, analogue input or via Modbus (see [3.4.2](#)). The Imperium controller will then regulate the temperature in the buffer tank (see [3.4.1](#)). [figure 3](#) shows a schematic representation of the central heating system.

Section [5.5.5](#) explains how to set up the central heating system.

3.4.1 Temperature control CH-system

There are two settings that are important for regulating the central heating system: the setpoint for the buffer tank temperature and the hysteresis. A heating cycle starts when there is a demand for heat and temperature sensor BT0x.TS01 registers a temperature below the setpoint, minus the set hysteresis. The heating cycle ends when this aforementioned temperature sensor registers a temperature above the setpoint. If two buffer tanks are installed, the temperature is determined by selecting the maximum value of the two temperature sensors.



Note:

The temperature of the outgoing water (BT0x.TS01) is not the temperature of the room. The (on/off) room thermostat, analogue input or building management system is responsible for controlling the heat demand from the building.

In a cascade of multiple heat pumps, the Imperium control will regulate the temperature in the buffer tank between the setpoint and the setpoint, reduced by the set hysteresis, by switching the heat pumps on and off.

If there is both a CC01 combi-cascade and a CC02 central heating cascade, the CC02 central heating cascade will initially be used for the central heating system. If this does not achieve the desired temperature, the CC01 combi-cascade will also be used for the central heating system, provided there is no heat demand from the DHW system.

3.4.2 CH-system control

The central heating system can be controlled in three ways:

1. Enable via the CH.enable contact (see [4.4.1](#)): this is an on/off signal (e.g. an on/off room thermostat). When the contact is closed, there is a heat demand; when the contact is open, there is no heat demand. In this case, the internal setpoint is used as the setpoint.
2. Enable and setpoint via the CH.AI analogue input (see [4.4.1](#)): this is a 0-10VDC input. The control based on the analogue input is activated when a voltage >1 VDC is detected. Between 1 and 2 VDC, there is no heat demand. Between 2 and 10 VDC, there is heat demand and the setpoint depends on the supplied voltage (default setting: central heating setpoint = voltage * 10).
3. Enable and setpoint via the Modbus RS485 BMS connection: if the Modbus control is activated (BMS visible at the top of the status bar), both the heat demand and the setpoint are controlled via the Modbus connection (see Appendix A).

Control via the Modbus RS485 BMS connection takes priority over the analogue input. Control via the analogue input takes priority over the internal control.

The current setpoint and the status of the central heating system are visible in the main screen (see [5.3](#)) and the central heating system information screen (see [5.4.2](#)).

3.4.3 CH back-up heaters

The buffer tanks can be equipped with a backup heater. A CH.BH relay contact is available for this purpose (see [4.4.1](#)). If the central heating system is enabled, this CH.BH relay contact is switched in the following situations:

- When the Imperium controller is in fault mode.
- The heat pump cannot reach the requested buffer tank setpoint due to an excessively low outside temperature (see [3.5.5.4](#)).

- As the final stage in the cascade control. For this, the central heating Power limit setting must not be activated (see [5.5.5](#)).



Warning

Set the internal thermostat of the electric elements to a temperature just above the maximum desired setpoint, so that the water temperature does not become too high in the event of a malfunction. A lower setpoint will prevent the desired setpoint from being reached.

3.5 The DHW system

The Imperium controller has two options for heating DHW, namely a one-pass and a multi-pass option. Based on the system installed at your location, multi-pass (MP) or a combination system (MP+OP) of both modes may be applicable.

The following system combinations are possible:

System combinations

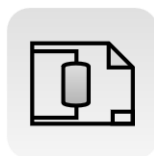

DHW system no.	No. DHW storage tanks [ST0x]	Series or Parallel configuration	One-pass (OP) or Multi-pass (MP)
1	1	-	MP + OP
2	1	-	MP
3	2	S	MP + OP
4	2	P	MP + OP
5	2	P	MP
6	3	S + 2P	MP + OP
7	3	P	MP + OP
8	3	P	MP

3.5.1 Multi-pass heating mode

Multi-pass heating cycle

In multi-pass heating mode, the water is pumped from the bottom of the storage tank via the heat exchanger to the lower hot water inlet of the storage tank. This is done with a fixed temperature difference of +/- 5 °C. This value may vary depending on the user settings. The advantage of this mode over the one-pass heating mode is that this method of heating is more efficient because the temperatures in a multi-pass cycle are lower on average.

There are two settings that are important for the multi-pass control. These are the multi-pass setpoint and the hysteresis. How to set these is described in section [5.5.1](#). The multi-pass sensor is located just above the multi-pass connections at the bottom of the tank. Consult the installation drawings for more information.

A multi-pass heating cycle starts as soon as the system is released for tap water via the digital input or the building management system and a temperature is registered on the relevant temperature sensor that is lower than the set setpoint, reduced by the set hysteresis.

The multi-pass heating cycle ends when the relevant temperature sensor has reached the setpoint value.

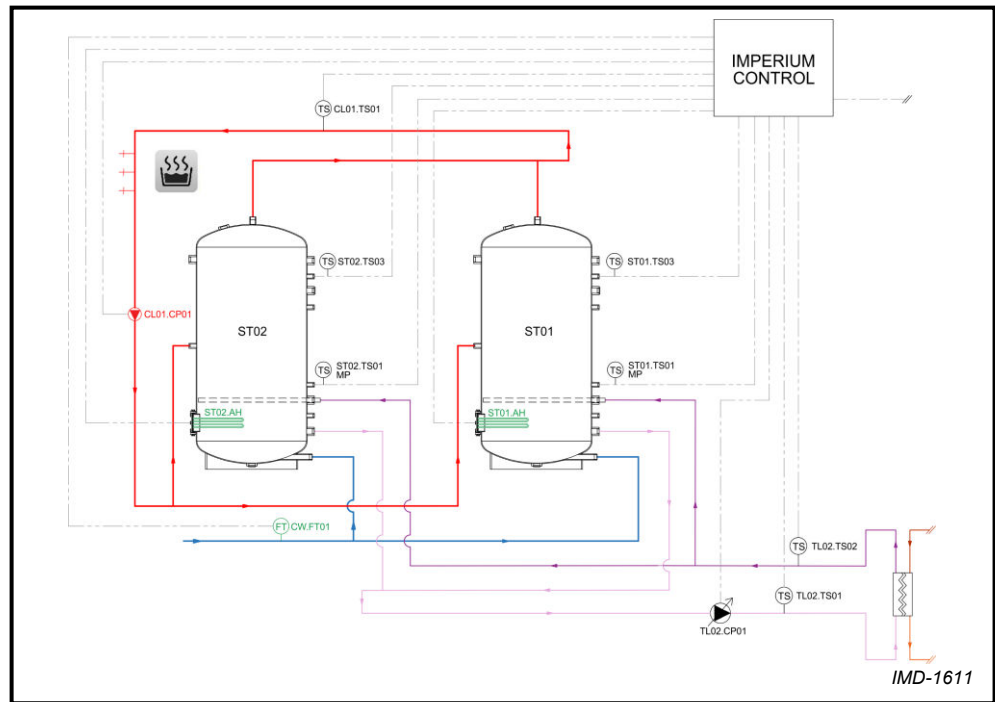

Figure 4 Hot Multi-pass heating system and its sensors

ST0x DHW storage tank (max. 3)

ST0x.TS01 Temperature sensor Multi-pass

ST0x.TS03 Temperature sensor booster heating (*optional*)

ST0x.AH Booster element (*optional*)

ST0x.BH Back-up element (*optional*)

TL02.CP01 Controlled DHW circulating pump

TL02.TS01 Temperature sensor incoming DHW temperature plate heat exchanger

TL02.TS02 Temperature sensor outgoing DHW temperature plate heat exchanger

CL01.TS01 Temperature sensor outgoing or circulating temperature

CL01.CP01 Circulating pump (*optional*)

3.5.2 One-pass heating mode

One-pass heating cycle

In one-pass heating mode, the water is pumped from the bottom of the storage tank via the heat exchanger to the top hot water inlet of the storage tank. The DHW is heated to the correct temperature in one go and can therefore be supplied directly to the hot water outlet. This increases comfort, as the heat pump is able to contribute directly to the draw-off capacity and restore the outlet temperature more quickly.

There are three settings that are important for the one-pass control. These are the one-pass setpoint, the hysteresis on the upper sensor (one-pass top hysteresis) and the hysteresis on the sensor mounted below it in the tank (one-pass bottom hysteresis). This can be a middle or lower sensor and depends on the installed tank configuration. Refer to the installation drawings for more information. These settings can be found in the DHW setpoints settings screen, see section [5.5.1](#).

A one-pass heating cycle starts when one of the two sensors measures a temperature that is lower than the setpoint, minus the set hysteresis. Normally, the one-pass bottom hysteresis is considerably larger than the one-pass top hysteresis. In the event of standstill loss, the one-pass heating mode will be activated based on the top sensor, allowing the entire one-pass stock to be heated. This leads to longer cycle times and reduces oscillating behaviour. In the event of a large tapping, the bottom sensor will ensure that the one-pass heating mode starts up more quickly in order to contribute to the tapping.

A one-pass heating cycle ends when the temperature has reached the setpoint on the top sensor, or when the bottom sensor has reached a temperature of the setpoint minus a system-dependent tolerance (standard 1 °C).

With multiple tanks connected in parallel, the temperature is based on the highest measured value of the sensors at the same position in the tanks.

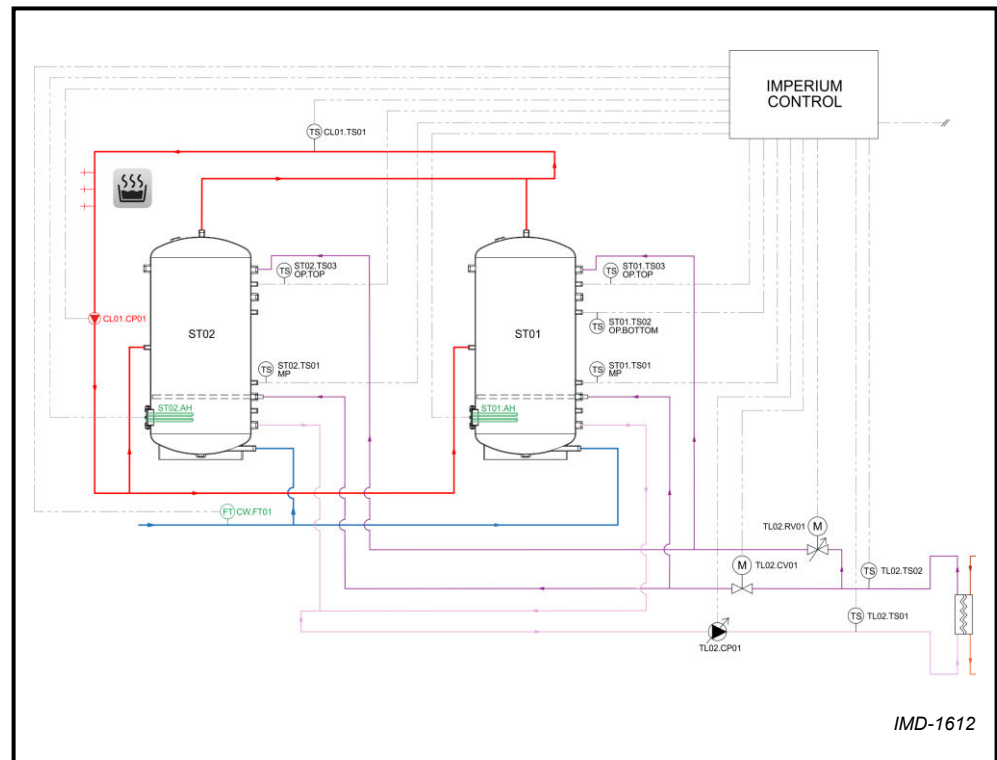

Figure 5 A switching heating system and its sensors in parallel configuration

ST0x DHW storage tank (max. 3)

ST0x.TS01 Temperature sensor one-pass bottom

ST0x.TS03 Temperature sensor one-pass top (+ booster heating)

ST0x.AH Booster element (optional)

ST0x.BH Back-up element (optional)

TL02.RV01 One-pass regulating valve

TL02.CP01 Controlled DHW circulating pump

TL02.TS01 Temperature sensor incoming DHW temperature plate heat exchanger

TL02.TS02 Temperature sensor outgoing DHW temperature plate heat exchanger

CL01.TS01 Temperature sensor outgoing or circulating temperature

CL01.CP01 Circulating pump (optional)

**Switching
OP + MP system**

3.5.3 Switching system one-pass and multi-pass

In a switching system, the one-pass and multi-pass modes work together to achieve an optimal combination of comfort and efficiency. This can be done with one to a maximum of three domestic hot water tanks.

In a system with a single domestic hot water tank, the upper part of the tank is heated by the one-pass heating mode and the lower part by the multi-pass heating mode.

With multiple domestic hot water tanks, it is preferable to heat the first tank (ST01) using the one-pass mode and the second and if necessary a third tank (ST02+ST03) using the multi-pass mode (see figure 6). This ensures an optimal separation between the two heating modes. In this configuration, the booster element is also placed in the first tank (ST01).

It is also possible to connect up to 3 DHW tanks in parallel in a combination system (similar to figure 4 and figure 5), whereby, as with 1 DHW tank, the upper part of the tanks is heated by the one-pass heating mode and the lower part by the multi-pass heating mode.

In a switching system, one-pass takes precedence over multi-pass.

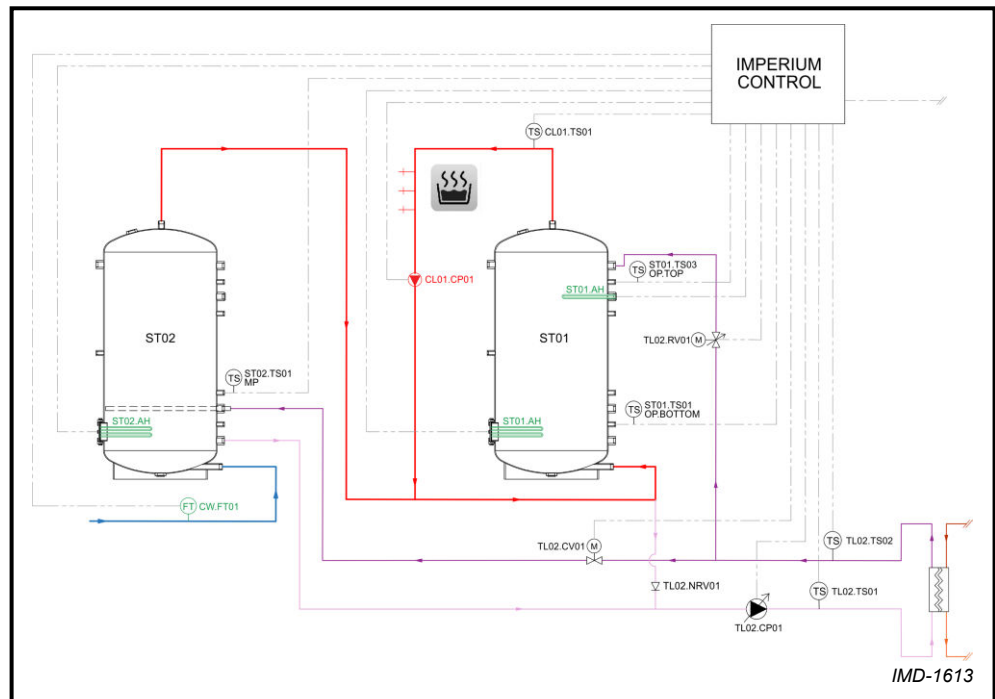

Figure 6 Switching heating system and its sensors

- ST01** DHW storage tank one-pass
- ST02** DHW storage tank multi-pass
- ST01.TS01** Temperature sensor one-pass bottom
- ST01.TS03** Temperature sensor one-pass top (+ booster heating)
- ST02.TS01** Temperature sensor multi-pass
- ST01.AH** Booster element (optional)
- ST0x.BH** Back-up element (optional)
- TL02.RV01** One-pass regulating valve
- TL02.CP01** Controlled DHW circulating pump
- TL02.TS01** Temperature sensor incoming DHW temperature plate heat exchanger
- TL02.TS02** Temperature sensor outgoing DHW temperature plate heat exchanger
- TL02.NRV01** Non-return valve transfer loop
- CL01.TS01** Temperature sensor outgoing or circulating temperature
- CL01.CP01** Circulating pump (optional)

3.5.4 Booster heating with electric elements

If higher temperatures are required than the heat pump can achieve, electric booster heating can be selected. An AH relay contact is available for this purpose (see [4.4.1](#)). The electric element is normally placed at the top of the tank, but can also be placed at the bottom of the tank if desired, if the entire supply must reach a higher temperature at all times.

In a 3 or 6 domestic hot water system, where a separate one-pass domestic hot water storage tank is configured, the booster heater also serves as a backup heating element for the one-pass domestic hot water storage tank.

The AH relay contact is activated when the heat pump has reached its maximum setpoint and the temperature measured at the upper sensor is below the one-pass setpoint, minus the hysteresis. The AH relay contact switches off when the one-pass setpoint on the upper sensor is reached. The settings for this are described in section [5.5.1](#).

It is also possible to set the system so that the electric element switches on when a large tapping is detected. A peak operation setpoint is available for this purpose. This is set to 5°C by default, which means it is not active. If a higher setpoint is set (e.g. 40°C), the booster heating will assist when the temperature measured on the upper sensor falls below this setpoint.



Warning

Set the internal thermostat of the electric elements to a temperature just above the maximum desired setpoint, so that the water temperature does not become too high in the event of a malfunction. A lower setpoint may prevent the desired setpoint from being reached.

3.5.5 Temperature control of the DHW system

The setpoints and hysteresis settings of the one-pass heating mode, multi-pass heating mode and booster heating elements provide a basic setting for the DHW system. In addition, there is a tap water user setpoint, ECO mode, legionella disinfection program and envelope limitation that influence the DHW temperatures.

The current setpoints and the status of the tap water system are visible in the main screen (see [5.3](#)) and the DHW system information screen (see [5.4.1](#)).



Warning

Ensure that the system is set up in accordance with local regulations (e.g. with regard to anti-legionella measures).

3.5.5.1 DHW user setpoint

This setpoint determines the maximum temperature of the DHW storage tanks and thus limits the individual one-pass, multi-pass and booster heating setpoints. The user setpoint can be adjusted using the '+' and '-' buttons on the main screen (see [5.3](#)) or via the DHW setpoint adjustment screen (see [5.5.1](#)).

The maximum setting for the tap water user setpoint is limited by the highest set value of the individual one-pass, multi-pass and booster heating setpoints.

Example:

The following tables show two examples with the same one-pass, multi-pass and booster setpoints, but with a different user setpoint. In the second table, the one-pass and booster setpoint are limited by the user setpoint, which has been reduced from 65 to 62 degrees.

Setpoint:	Setting:	Result:
User	65°C	65°C
One-pass (+ booster)	65°C	65°C
Multi-pass	60°C	60°C

Setpoint:	Setting:	Result:
User	65°C → 62°C	62°C
One-pass (+ booster)	65°C	65°C → 62°C
Multi-pass	60°C	60°C

3.5.5.2 ECO mode

ECO mode allows you to temporarily set a lower or higher DHW user setpoint (see [5.5.2](#)). This can be useful for limiting standby losses or buffering extra energy. ECO mode has a higher priority than the DHW user setpoint.

ECO mode can be activated via a week program (see [5.5.2](#)) or via the DHW.ECO.enable contact (see [4.4.1](#)). During ECO mode, it is possible to open the CL01.CP01 relay contact (see [4.4.1](#)) so that, for example, a circulation pump can be temporarily switched off.



Note

The ECO program with associated settings can also be activated via the digital input DHW.ECO.Enable (see [4.4.1](#)). This makes it possible, for example, to buffer energy from solar panels in the tap water system.

3.5.5.3 Legionella disinfection program

To prevent contamination with legionella, it is possible to temporarily increase the DHW temperature once a week. The legionella disinfection program always takes priority over the DHW user setpoint and ECO mode. The settings for the legionella disinfection program can be found in section [5.5.2.2](#).

When the legionella disinfection program is active, the legionella symbol is visible in the status bar (see [5.1](#)).

3.5.5.4 Envelope limitation

The control system is equipped with an envelope limitation that ensures that internal setpoints are adjusted if the heat pump can no longer achieve the desired temperature. The envelope also limits the maximum setting for the one-pass and multi-pass setpoints, taking into account tolerances and losses relative to the maximum envelope temperature of the heat pump. The envelope limitation is heat pump dependent and therefore cannot be adjusted.

When the envelope limitation is active, this is indicated by an envelope icon in the status bar (see [5.1](#)). In addition, the envelope icon is displayed next to the relevant setpoint in the hot water and central heating system information screen (see [5.4.1](#) and [5.4.2](#)).

3.5.6 DHW system control

The domestic hot water system can be controlled in two ways:

1. DHW heating via the DHW.enable contact (see [4.4](#)): this is an on/off signal (e.g. from a BMS). When the contact is closed, there is a heat demand; when the contact is open, there is no heat demand. In this case, the internal setpoint is used as the tap water user setpoint. This contact is short-circuited at the factory.
2. DHW heating and set the DHW user setpoint via the Modbus RS485 BMS connection: if the Modbus control is activated (BMS visible at the top of the status bar), both the heat demand and the tap water user setpoint are controlled via the Modbus connection (see [Appendix A](#)).

Control via Modbus RS485 BMS takes priority over the internal control system ng.

The current setpoints and the status of the hot water system are visible in the main screen (see [5.3](#)) and the domestic hot water system information screen (see [5.4.2](#)).

3.5.7 DHW back-up elements

The domestic hot water storage tanks can be equipped with a backup element in the multi-pass section of the DHW storage tank. A DHW.BH relay contact is available for this purpose (see [4.4.1](#)). If the DHW system is enabled, this DHW.BH relay contact is switched in the following situations:

- When the Imperium controller is in fault mode.
- The current multi-pass setpoint is higher than the current value of the envelope limit (see [3.5.5.4](#)). For example, due to a cold ambient temperature, or an increased multi-pass setpoint to buffer extra energy. In this case, the envelope icon is visible and, depending on the DHW Power limit setting, the DHW.BH relay contact is activated immediately or only when the heat pump has reached its maximum setpoint.
- As the final stage in the cascade control. For this, the DHW Power limit setting must not be activated.



Warning

Set the internal thermostat of the electric elements to a temperature just above the maximum desired setpoint, so that the water temperature does not become too high in the event of a fault. A lower setpoint may mean that the desired setpoint cannot be reached.

4 Installation



Warning

The installation must be carried out in accordance with the general and locally applicable regulations of water supply companies, electricity companies and the fire brigade, by a certified installer.



Caution

The Imperium Controller may only be installed in rooms that comply with the required national and local regulations.

4.1 Introduction

This chapter describes the environmental conditions that the installation room must meet and the installation steps that must be carried out before the Imperium Controller can be permanently installed. This chapter also describes the mechanical and electrical installation of the controller.

4.2 Ambient conditions

The installation room must be frost-free or protected against frost. The table shows the environmental conditions that must be met in order to guarantee the functioning of the electronics used.

Air humidity	Max. 95% @ 25 °C
Ambient temperature	$10 \geq T \geq 50$ °C

4.3 Mechanical installation

4.3.1 Mounting instructions

A mounting kit is supplied as standard with every Imperium controller.

The following installation instructions must be observed to ensure proper installation and troublefree operation:

- Carefully remove the packaging to prevent damage to the product.
- Ensure that the surface is stable and flat.
- Choose the desired location for the cabinet and mark the position on the wall.
- Determine where the mounting points should be located; first read the supplied mounting instructions.
- Mark the drill holes on the wall, taking into account the position of the mounting points.
- Insert the appropriate plugs into the drilled holes. Secure the cabinet to the wall using screws that are suitable for the plugs and the type of wall.
- Ensure that the cabinet is level and check its stability.

4.3.2 Dimensions

The dimensions of the cabinet are shown in [figure 7](#) below.

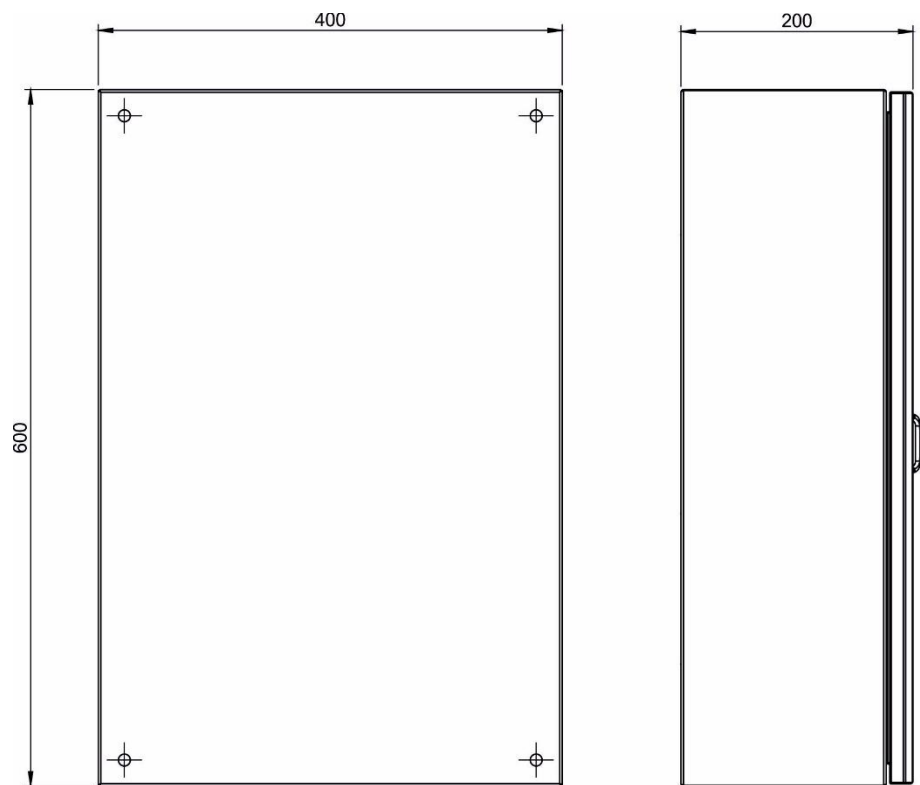

Figure 7 Dimensions of the Imperium controller

IMD-1590 R0

4.4 Electrical connections



Warning

The installation must be carried out by a certified installer in accordance with general and local regulations.

Note

For the abbreviations and symbols used, see the corresponding installation diagram.



Note

There is a sticker on the base plate of the cabinet showing the connection terminals as described below.

4.4.1 Terminal blocks

The terminal blocks are numbered in ascending order, from left to right, starting at 1 and ending at 77. The terminal blocks are positioned at the top right (1-3) and bottom (4-77).

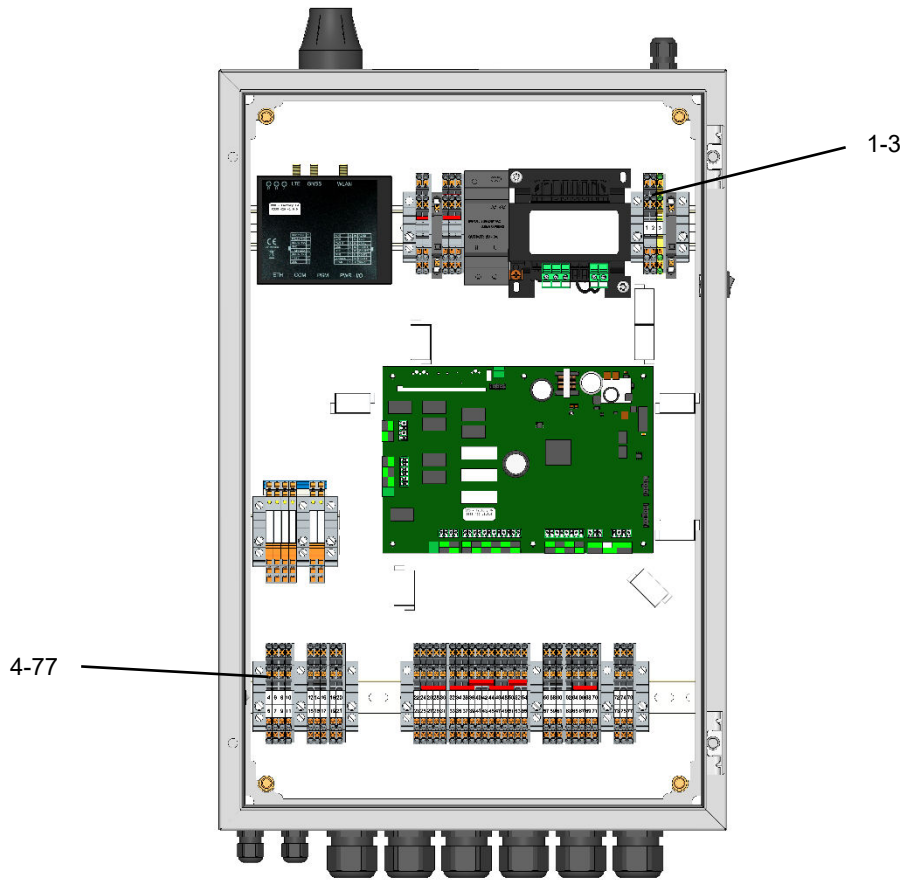

Figure 8 Location of terminal strips

Power supply

Power supply voltage: (230VAC / 50Hz / 1,45 A)			
	Terminal	ID	Explanation
	1	L	Phase
	2	N	Neutral
	3	PE	Earth

Relay contacts

Relay contacts (230VAC / max. 2A)			
	Terminal	ID	Explanation
	4	CH.BH	Back-up element CH (BT0x.BHxx in scheme)
	5		
	6	DHW.BH	Back-up element DHW (ST0x.BHxx in scheme)
	7		
	8	AH	Booster element DHW (ST0x.AHxx in scheme)
	9		
	10	CL01.CP01	Recirculating pump
	11		

Changeover valves

Changeover valves (24VAC / max. 2A)			
	Terminal	ID	Explanation
	12	TL01.CV	Changeover valve DHW (DO=0) / central heating (DO=1)
	14		
	16		
	13	TL02.CV	Changeover valve Multi-pass (DO=1) / One-pass operation (DO=0)
	15		
17			
A 24VAC power supply (-/+) and 24VAC switched output are available for each valve.			

Circulating pumps

Start-stop contacts additional circulating pumps (max. 24V / 50mA - SELV)			
	Terminal	ID	Explanation
	18	TL01.CP01	Additional circulating pump combi cascade system (CC01)
	19		
	20	TL02.CP02	Additional circulating pump additional heating cascade system (CC02)
21			
In case of too little pump head of the internal heat pump circulation pump(s) these additional circulation pumps can be used (in series) with the internal pump or in combination with an open header.			

Building management system

Building management system (BMS) connections (max. 24V / 50mA - SELV)			
	Terminal	ID	Explanation
	22	Alarm	Alarm output contact (open = no alarm)
	23		
	24	DHW.Enable	DHW enable contact
	25		
	26	DHW.ECO.Enable	ECO enable contact
	27		
	28	CH.enable	Release contact central heating
	29		
	30	CH.AI	Setpoint central heating based on 0-10VDC signal*
31			
<p>* Functionality CH.AI: 0V...1V: Input not active 1V...2V: Input active but no central heating release 2V...10V: Central heating release with setpoint based on analog input</p>			

Temperature sensors

Temperature sensors (NTC 10k @ 25 °C, $\beta = 3435 K @ 25 / 85 °C$)		
Terminal	ID	Explanation
32 33	TL01.TS01 (T1)	Incoming DHW temperature plate heat exchanger
34 35	TL02.TS02 (T2)	Outgoing DHW temperature plate heat exchanger
36 37	ST01.TS01 (T3)	Bottom temperature DHW storage tank 1
38 39	ST01.TS02 (T4)	Middle temperature DHW storage tank 1
40 41	ST01.TS03 (T5)	Top temperature DHW storage tank 1
42 43	ST02.TS01 (T6)	Bottom temperature DHW storage tank 2
44 45	ST02.TS03 (T7)	Top temperature DHW storage tank 2
46 47	ST03.TS01 (T8)	Bottom temperature DHW storage tank 3
48 49	ST03.TS03 (T9)	Top temperature DHW storage tank 3
50 51	BT01.TS01 (T10)	Temperature central heating buffer tank 1
52 53	BT02.TS01 (T11)	Temperature central heating buffer tank 2
54 56	CL01.TS01 (T12)	DHW outgoing or recirculation temperature

Optional sensors

Pressure / flow transmitters (optional, 24VDC / 0-10V - SELV)		
Terminal	ID	Explanation
56	TL01.PT01	Pressure transmitter for heat pump hydronic pressure measurement (optional)
58		
60		
57	CW.FT01	DHW flow transmitter (optional)
59		
61		
A 24VDC power supply and a scalable 0-10VDC input with common zero (G) are provided for each sensor.		

DHW circulating pump

DHW circulating pump (TL02.CP01) (max. 24V / 50mA - SELV)		
Terminal	ID	Explanation
62	S/S	Start-stop contact
63		
64	ALARM	Alarm contact (closed = no alarm, open = alarm)
65		
66	0-10V	0-10VDC control signal
67	G	
Note: for the proper functioning of the Imperium system, the DHW circulating pump prescribed by the manufacturer must be used.		

OP DHW regulating valve

One-pass DHW regulating valve (TL02.RV01) (24VAC / max. 2 A)		
Terminal	ID	Explanation
68	0-10V	0-10VDC control signal
69	G	
70	24VAC	24VAC power supply (max. 2A)
71	G	
Note: for the proper functioning of the Imperium system, the DHW regulating valve prescribed by the manufacturer must be used.		

Modbus connections

Modbus BMS + HP (RS485)			
	Terminal	ID	Explanation
	72	G	Modbus connection Building management system (BMS)* (115.200kbs; 8E1; Adres 1)**
	74	B/-	
	76	A/+	
	73	G	Modbus connection for heat pumps (19.200kbs; 8E1)**
	75	B/-	
	77	A/+	
Visit www.modbus.org for more information about the modbus protocol.			
* Modbus address list is available in this manual. ** Baud rate and address are adjustable.			
Specifications Modbus cabel:			
Number of cores: 2, twisted pair, shielded		Wire diameter: 0,25 mm2	
Maximum cable length: 1.200 m @ 1.900 bps, 150 m @ 115.200 bps		Impedance: 120 Ω Ground to terminal block.	

4.4.2 Heat pump Modbus connections

The Imperium controller uses Modbus communication to control the heat pumps. For correct operation, the cabling must be connected in series. This means that the G, "-" and "+" connections from terminals 73, 75 and 77 must be connected to the corresponding connections in the first heat pump and from there connected to the next heat pumps (see Figure 9). Use a suitable cable as specified above. For long cable lengths, apply a 120 Ω terminating resistor at the beginning and end of the Modbus cable.

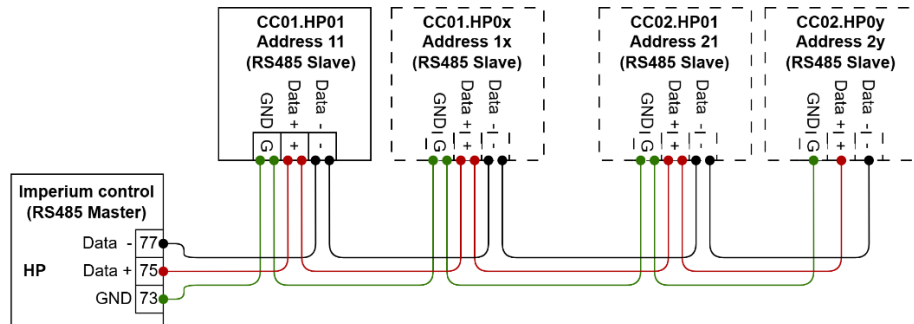

Figure 9 Modbus connections to heat pumps

The addresses for the heat pump are predefined and must be set on the relevant heat pumps according to the table below. Consult the heat pump instruction manual for setting the Modbus addresses.

CC01.HP0x			CC02.HP0y						
.HP01	.HP02	.HP03	.HP01	.HP02	.HP03	.HP04	.HP05	.HP06	.HP07
Addr.	Addr.	Addr.	Addr.	Addr.	Addr.	Addr.	Addr.	Addr.	Addr.
11	12	13	21	22	23	24	25	26	27

5 Control panel

























The control interface consists of a (touchscreen) display for navigating through the menus, displaying faults and entering settings, functions and values.

The display is fully menu-driven. The user can change settings and check the status of the DHW system.

5.1 Most used symbols

This section describes the most used symbols on the control panel.

List of symbols

	Indicator buttons, these indicate or allow setting of a parameter		
	Heat pump installation scheme		DHW installation scheme
	Multi-pass heating mode		One-pass heating mode
	Number of heat pumps in DHW or combi cascade (CC01)		Number of heat pumps in central heating cascade (CC02)
	Start		Stop
	Temperature		Ambient temperature
	Outgoing or recirculation temperature (CL01.TS01)		ECO temperature
	Clickable button, pressing these take the user to a new screen		
	Confirm selection		Back to home screen
	Week program (see 5.5.2)		Components information (see 5.4)
	Settings (see 5.5)		Go back one screen
	Plus, adds 1 to parameter		Minus, subtracts 1 from parameter
	Clock		Temperature settings

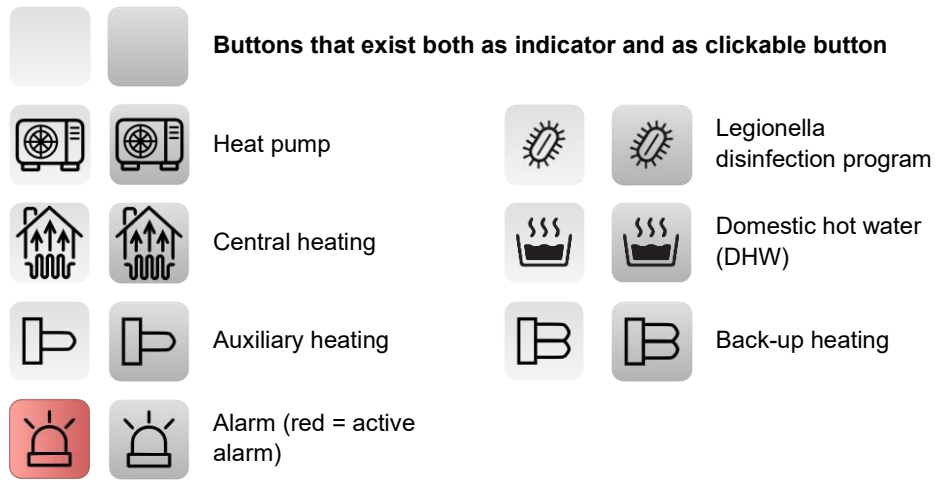

Other types of buttons and indicators

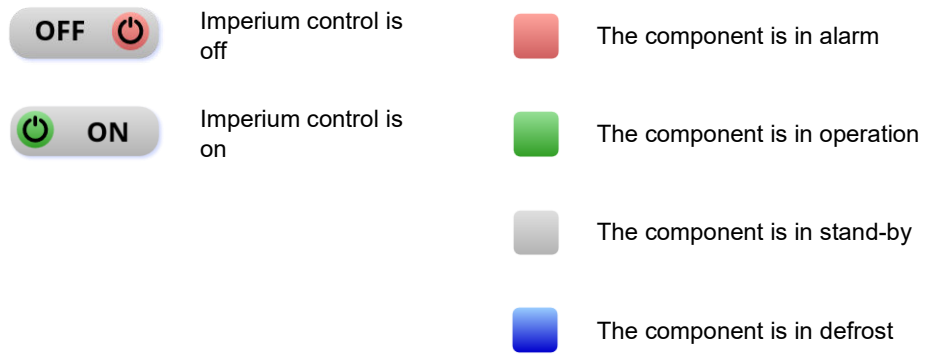

Status bar indicators

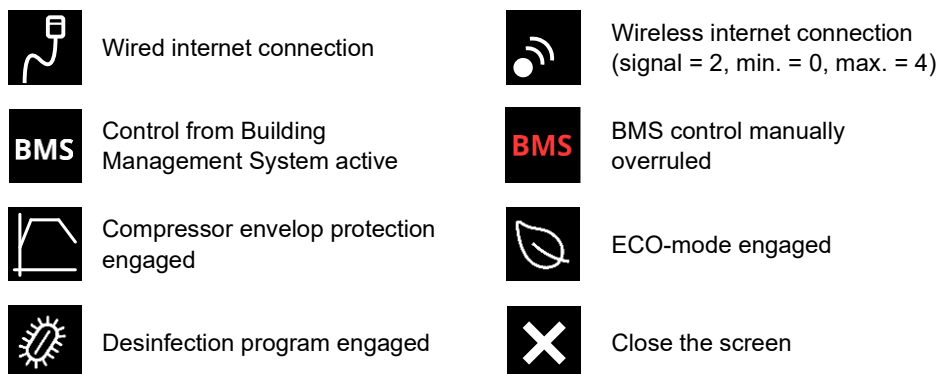

5.2 Configuration screen

Configuration
screen

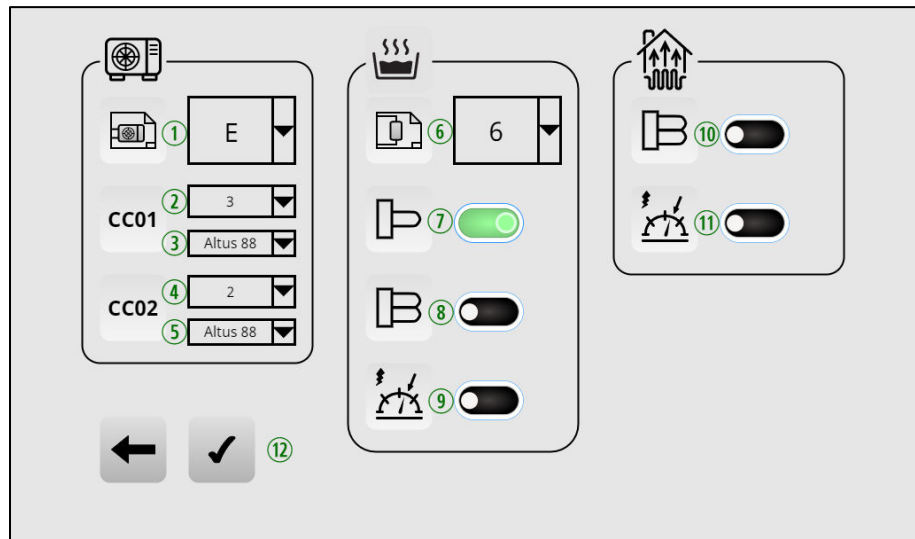

Figure 10 Opening screen of the Imperium controller during initial start-up

When the Imperium controller is switched on for the first time, the user is asked to enter some information about the installation. This information can be found on the installation diagram. If the installation diagram is not available, the flow diagram in [figure 11](#), can be used to determine this code.

To ensure proper operation, the following data must be set:

- 1 = Heat pump installation schematic (letter in schematic).
- 2 = Number of heat pumps in DHW or combi cascade system (CC01).
- 3 = Type of heat pump in DHW or combi cascade system (CC01, for code see 1.2).
- 4 = Number of heat pumps in additional central heating cascade system (CC02).
- 5 = Type of heat pump in additional central heating cascade system (CC02, for code see 1.2).
- 6 = DHW installation schematic (number in schematic).
- 7 = Auxiliary immersion heaters installed (STxx.AHxx in schematics).
- 8 = Back-up immersion heaters in buffer tank installed (BTxx.BHxx in schematics).
- 9 = Power limit setting for DHW backup heating. If this setting is activated, the backup heating will not be activated when a heat pump is active.
- 10 = Back-up immersion heaters in buffer tank installed (BTxx.BHxx in schematics).
- 11 = Power limit setting for central heating backup heating. If this setting is activated, the backup heating will not be activated when a heat pump is active.
- 12 = Navigational buttons.

Pressing the confirm button (10) prompts the user to confirm their choices. Once the settings have been confirmed, the screen layouts are saved. Instructions on how to reset the controller can be found in section [5.5](#).

If certain parts of the installation are not installed, they will not be displayed.

Flowcharts for determining the installation code

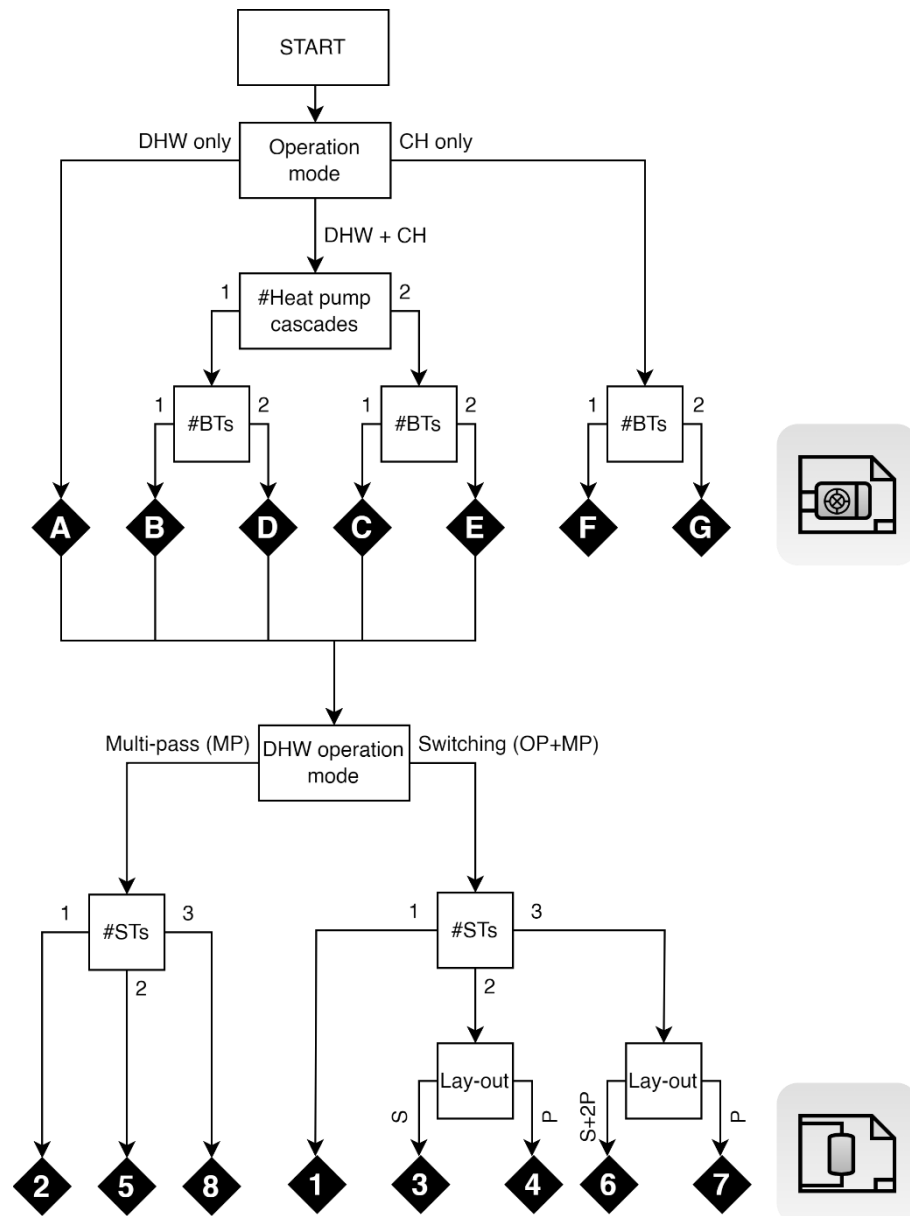

Figure 11 Flow chart for determining the installation code

Legenda

- #BTs** No. of buffer tanks
- #STs** No. of storage tanks
- S** DHW tanks in series (*OP* = *ST01*, *MP* = *ST02*)
- P** DHW tanks in parallel (*Tichelmann*)
- S+2P** DHW tanks in series + parallel (*OP* = *ST01*, *MP* = *ST02* + *ST03*)

5.3 Main screen

Once all data has been set, the user will see the main screen.

Main screen

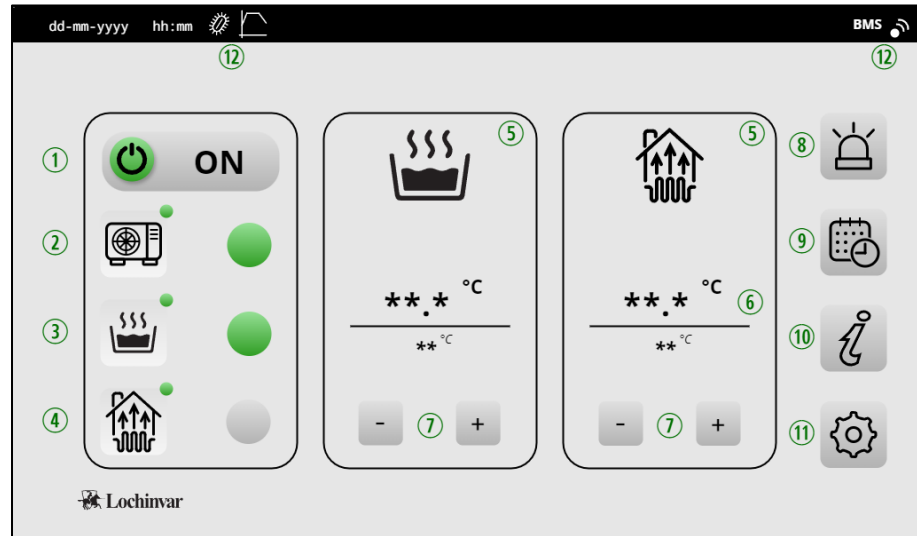

Figure 12

- 1 = Activate or deactivate the Imperium controller (hold for 3 seconds).
- 2 = Status heat pump, small indicator indicates demand from the system, the big indicator indicates an engaged heat pump.
- 3 = Status DHW-system, small indicator indicates system release, the big indicator indicates a DHW-system engaged.
- 4 = Status CH-system, small indicator indicates system release, the big indicator indicates a CH-system engaged.
- 5 = Information on DHW- (left) or CH-system (right).
- 6 = Actual temperature (upper) and setpoint temperature (lower).
- 7 = Buttons to change setpoint temperature.
- 8 = Button to go to the alarm screen (see 5.6).
- 9 = Button to go to the ECO mode settings (see 5.5.2).
- 10 = Button to go to the information screen (see 5.4).
- 11 = Button to go to the settings menu (see 5.5).
- 12 = Status indicators on the date and time bar (for more information see 5.1).

If certain parts of the installation are not installed, they will not be displayed.

5.4 Information screens

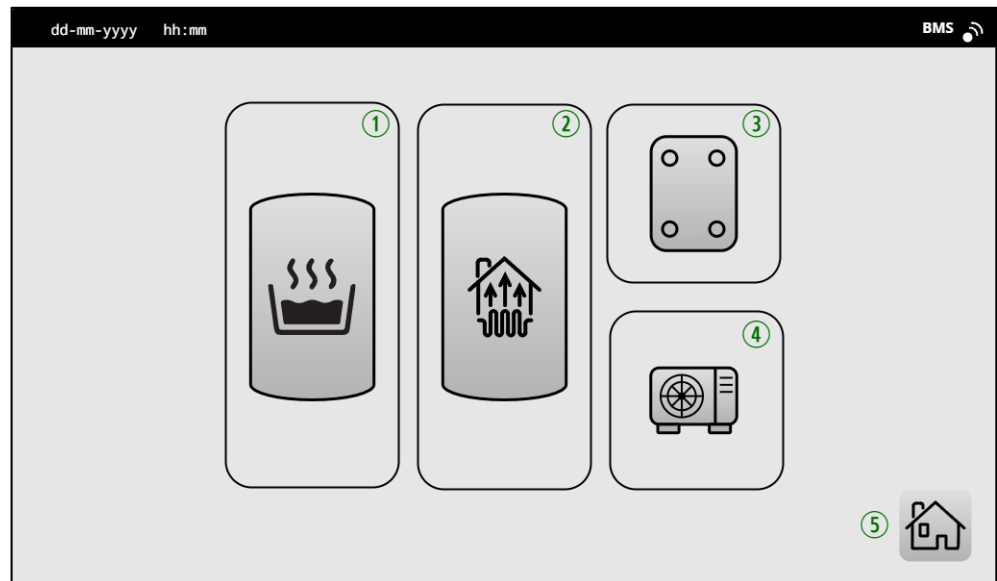

Figure 13

When the information button on the main screen is pressed, the user sees the information screen with the applicable components in the system.

- 1 = DHW system (see [5.4.1](#)).
- 2 = Central heating system (see [5.4.2](#)).
- 3 = Plate heat exchanger and transfer loop components (see [5.4.3](#)).
- 4 = Heat pump information (see [5.4.4](#)).

If certain parts of the installation are not installed, they will not be displayed.

5.4.1 DHW system information

DHW screen

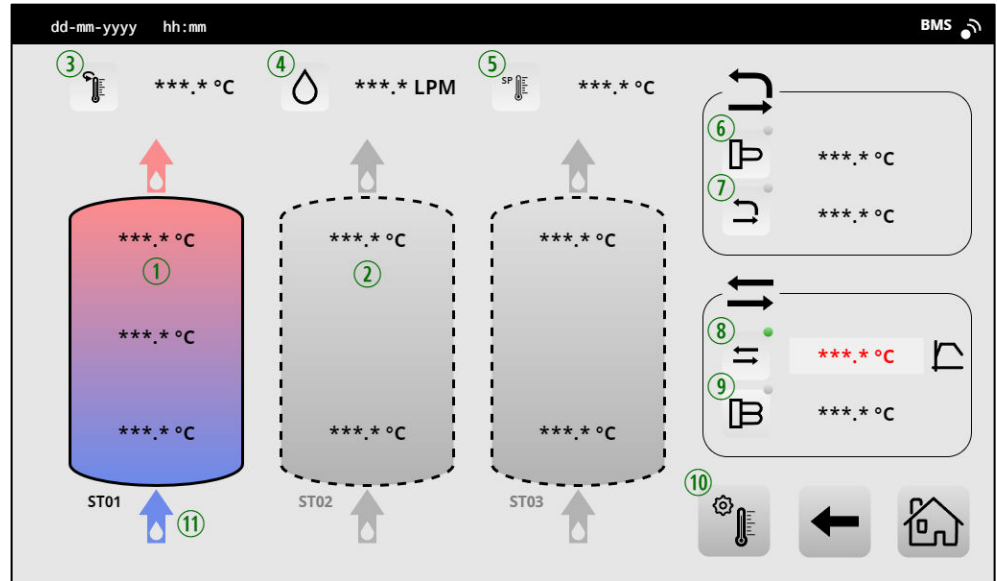

Figure 14

Various parameters of the tap water system can be viewed and set in the DHW screen. If an icon is visible and setpoints are colored red, the relevant setpoint is limited by the compressor envelope.

- 1 = The status of the tank, including temperatures. The tank that is being heated is colored. Depending on the settings, this may be 1 or more.
- 2 = If the tank is not being heated, it is displayed in grey.
- 3 = Cold water flow rate recorded by CW.FT01 (if installed).
- 4 = Outgoing or recirculation temperature.
- 5 = Current setpoint of the DHW system.
- 6 = Current setpoint for booster heating (AH, green indicator means AH active).
- 7 = Current setpoint for one-pass (OP, green indicator means OP active).
- 8 = Current multi-pass setpoint (MP, green indicator means MP active).
- 9 = Status of the backup heating (BH, green indicator means BH active).
- 10 = Setting screen for various DHW setpoints (see 5.5.1).
- 11 = Flow direction of DHW (colored when flow is detected by CW.FT01).

If certain parts of the installation are not installed, they will not be displayed. The placement of icons is also determined by the installation code.

5.4.2 Central heating system information

CH-screen

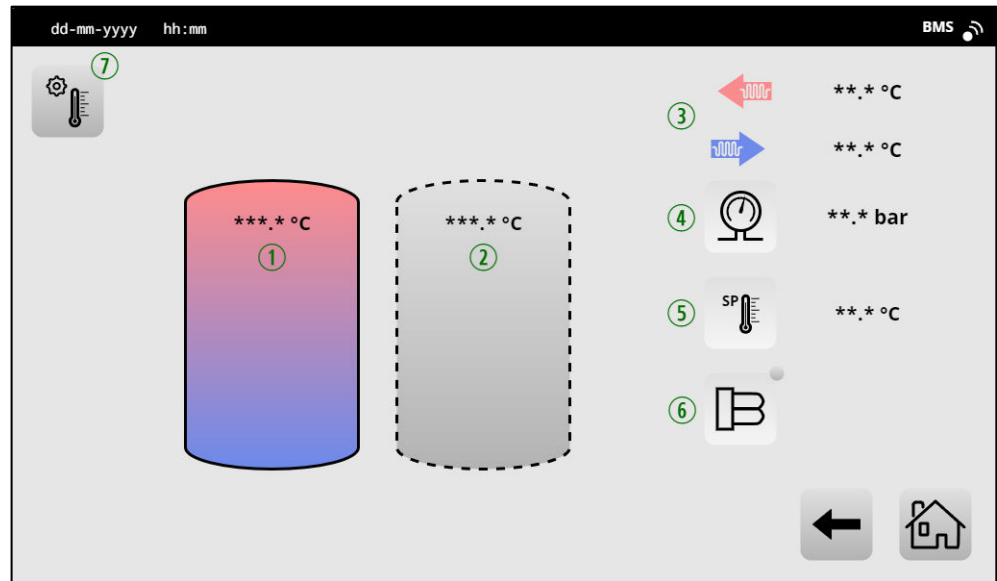

Figure 15

Various parameters of the central heating system can be viewed and set in the central heating system screen. If an icon is visible and setpoints are colored red, the relevant setpoint is limited by the compressor envelope.

- 1 = The status of the tank, including temperatures. The tank that is being heated is colored. Depending on the settings, this may be 1 or more.
- 2 = If the tank is not being heated, it is displayed in grey.
- 3 = Temperatures of supply and return (calculated if the heat pump system is switched on and in central heating mode).
- 4 = Central heating system pressure reading (*if installed*).
- 5 = Current central heating temperature setpoint.
- 6 = Status of the backup heating (BH, green indicator means BH active).
- 7 = Setting screen for the various central heating system setpoints (see [5.5.5](#)).

5.4.3 Information about plate heat exchanger and transfer loop components

Plate heat exchanger information

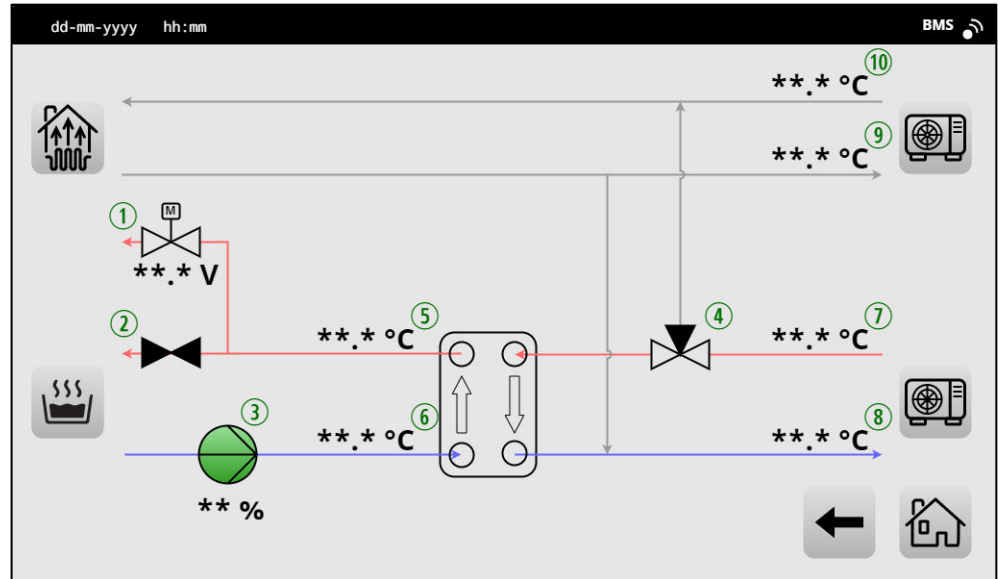

Figure 16

In the plate heat exchanger screen the user can find information about the heat exchanger temperatures, the transfer loop pump (TL02.CP01) and information about the valve statuses that control the behaviour of the central heating or DHW system or the one-pass (OP) and multi-pass (MP) system (if applicable).

- 1 = Status of the one-pass regulating valve (TL02.RV01), including the control signal.
- 2 = Status of the multi-pass/one-pass changeover valve (TL02.CV01).
- 3 = Status of the transfer loop pump (TL02.CP01), including speed.
- 4 = Status of the three-way valve (TL01.CV01).
- 5 = Incoming temperature DHW tank (TL02.TS01).
- 6 = Outgoing temperature DHW tank (TL02.TS02).
- 7 = Outgoing temperature heat pump(s) (CC01, calculated).
- 8 = Incoming temperature heat pump(s) (CC01, calculated).
- 9 = Outgoing temperature heat pump(s) (CC02, calculated).
- 10 = Incoming temperature heat pump(s) (CC02, calculated).

If certain parts of the installation are not installed, they will not be displayed. The placement of icons is also determined by the installation code.

5.4.4 Heat pump information

Heat pump information

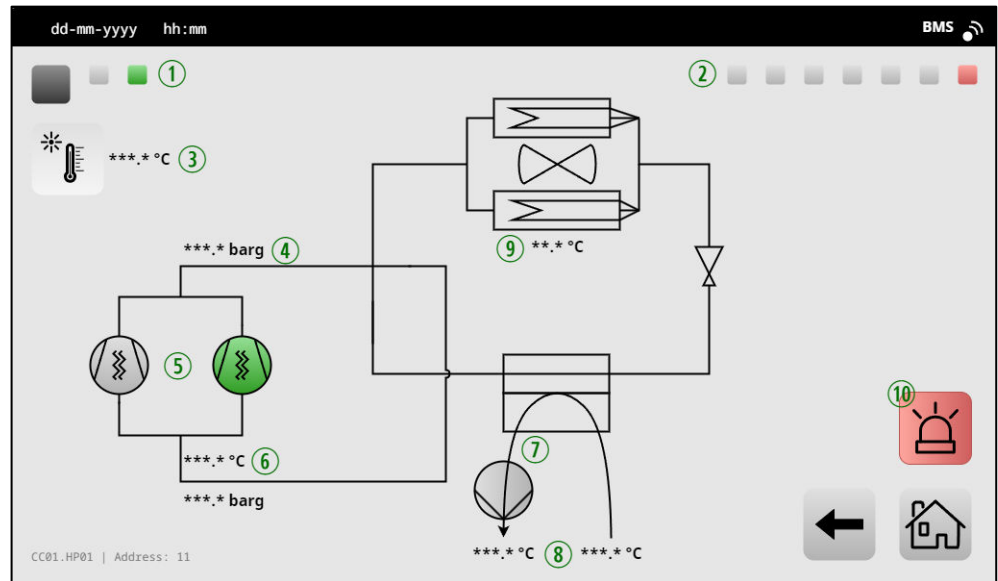

Figure 17

The heat pump information screen provides the user with information about the heat pump system. The user can switch between heat pumps by pressing the relevant block (1, 2). A green block indicates a heat pump in operation, grey indicates a heat pump in standby mode and red indicates a heat pump in alarm mode. Component status is displayed in green (in operation) or grey (standby).

- 1 = Heat pumps in the DHW or combi-cascade system (CC01, max. 3).
- 2 = Heat pumps in the (additional) heating cascade system (CC02, max. 7).
- 3 = Outdoor temperature (measured at the selected heat pump).
- 4 = Compressor pressure on the discharge side.
- 5 = Compressor status.
- 6 = Compressor pressure and temperature suction side.
- 7 = Status circulating pump (CC0x.HP0x.CP01).
- 8 = Condenser inlet and outlet temperatures (CC0x.HP0x.TS01 en TS02).
- 9 = Evaporator temperature.
- 10 = Alarm signal active.

5.5 Settings

Various control settings can be configured in the settings screen. Some of these settings can also be accessed via other screens (such as the DHW screen).

Settings screen

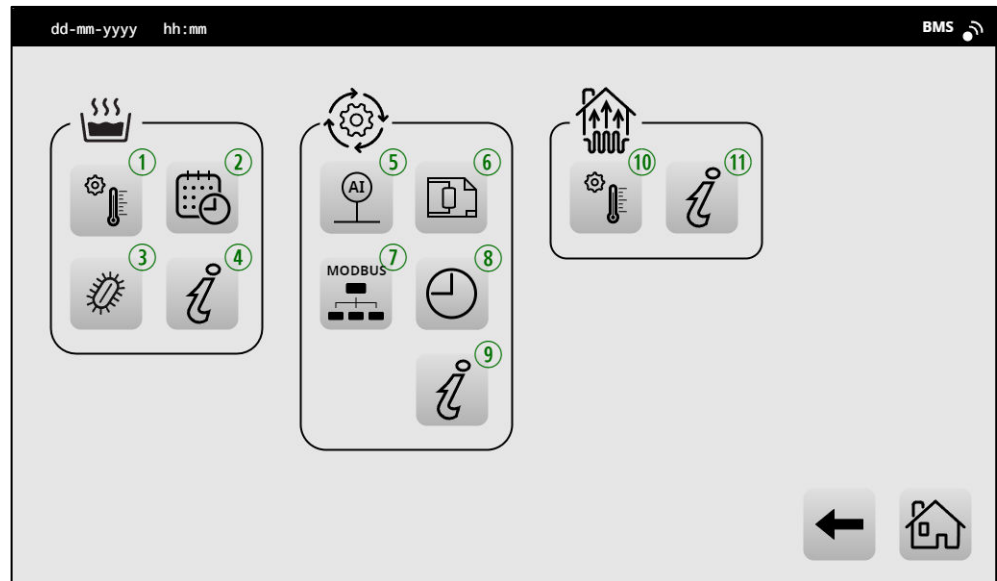

Figure 18

- 1 = Set the temperature settings for the DHW (see [5.5.1](#)).
- 2 = Set the week program (see [5.5.2](#)).
- 3 = Set the legionella disinfection program (see [5.5.2.2](#)).
- 4 = Go to the DHW information screen (see [5.4.1](#)).
- 5 = Configure the analogue inputs of the controller (see [5.5.3.1](#)).
- 6 = Reset the heat pump configuration (see [5.2](#)).
- 7 = Set the Modbus parameters for connection to the building management system and heat pump (see [5.5.4](#)).
- 8 = Set the current time of the controller (see [5.5.2.1](#)).
- 9 = Information about the software versions of SCB, UIM and IOT-modem.
- 10 = Set the temperatures of the central heating section (see [5.5.5](#)).
- 11 = Go to the central heating information screen (see [5.4.2](#)).

5.5.1 Domestic hot water setpoint settings screen

DHW setpoint settings screen

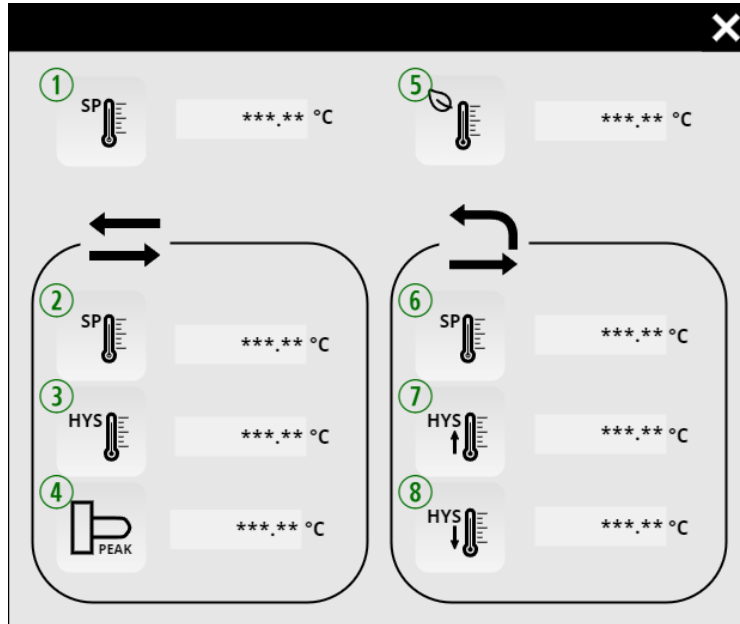

Figure 19

This screen allows you to configure the various setpoint settings for the DHW system. Depending on the configuration, some values may or may not be visible. A detailed explanation of the DHW setpoint control can be found in section [3.5](#).



Caution

Changing these settings can affect the comfort level, energy consumption or sustainability of the installation and should only be changed by a competent person.

- 1 = DHW user setpoint, (see [3.5.5.1](#)). This setpoint can also be adjusted using the buttons on the home screen and limits the other setpoints. It determines the maximum temperature of the DHW storage tanks. The maximum setting is limited by settings 1, 2, 5 and/or 9.
- 2 = Setpoint temperature for multi-pass heating mode. The maximum setting is limited based on the selected heat pump or is configured at 85C as a backup heating element.
- 3 = Switch-on hysteresis for multi-pass heating mode.
- 4 = Setpoint temperature peak operation (see [Error! Reference source not found.](#)).
- 5 = Setpoint temperature ECO program (see [5.5.2](#)).
- 6 = Setpoint temperature for the one-pass heating mode. The maximum setting is limited based on the selected heat pump or at 85C if a booster heating element is configured
- 7 = Switch-on hysteresis upper sensor for the one-pass heating mode (STxx.TS03).
- 8 = Switch-on hysteresis for the lower sensor for the one-pass heating mode.

5.5.2 ECO mode (week program)

ECO mode

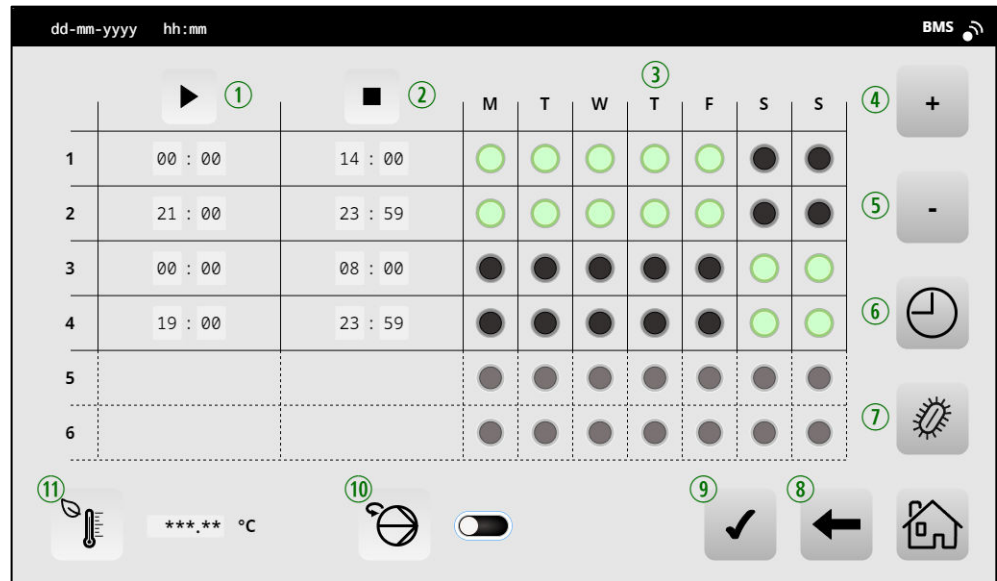

Figure 20

An ECO program can be programmed to temporarily increase or decrease the water temperature (see [3.5.5.2](#)). Up to 6 time blocks can be defined.

- 1 = Start time of the ECO program block.
- 2 = End time of the ECO program block.
- 3 = Days of the week when the ECO program is active.
- 4 = Add a block.
- 5 = Removing a block; the minimum number of setting blocks is 1.
- 6 = Setting the current time of the controller (see [5.5.2.1](#)).
- 7 = Setting the optional legionella disinfection program (see [5.5.2.2](#)).
- 8 = Return to the previous screen.
- 9 = Confirm your selections.
- 10 = Switching the circulating pump (CL01.CP01) on or off during the ECO program.
- 11 = Set the temperature setpoint during the ECO program.



Note

The ECO program with associated settings (10 and 11) can also be activated via the digital input DHW.ECO.Enable (see [4.4.1](#)). This makes it possible, for example, to buffer energy from solar panels in the tap water system.



Caution

Adjusting these settings can affect the comfort level, energy consumption or sustainability of the installation and should only be adjusted by a competent person.

5.5.2.1 Time and date settings

In the time and date settings screen, the user can adjust the time and date settings. The order is day – month – year, hour : minute. A time zone can also be selected here.

Time and date settings



Figure 21

5.5.2.2 Legionella disinfection program

In order to comply with local regulations, it may be necessary to set up a weekly legionella prevention program.

Legionella disinfection program

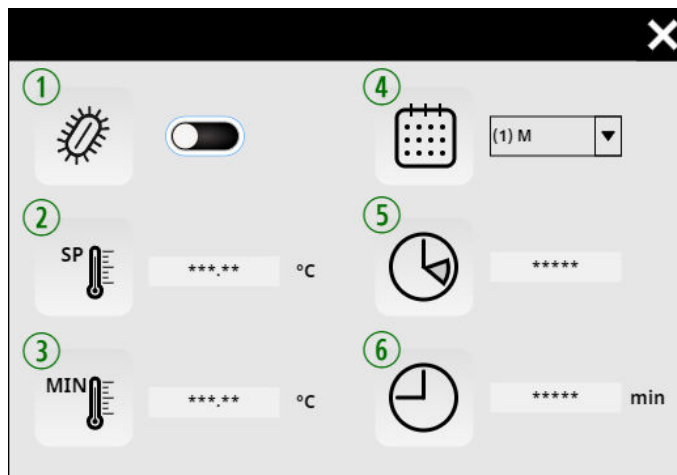

Figure 22

- 1 = Legionella disinfection program activation button.
- 2 = DHW setpoint temperature during legionella disinfection program. The maximum setting is limited by settings 2, 4 and/or 7 from section 5.5.1.
- 3 = Minimum temperature to be achieved during the legionella disinfection program.
- 4 = Day of the week when the legionella disinfection program is active (1 = Monday, 2 = Tuesday, etc.).
- 5 = Time when the legionella disinfection program starts.
- 6 = Duration that the DHW must have been above the minimum temperature to be achieved (3).

5.5.3 Configuration analogue inputs

Analogue inputs



Figure 23

The analogue inputs can be configured in this screen. Each input has a fixed function and can only be switched on or off.

- 1 = Analogue input building management system (BMS.CH.AI), (see [5.5.3.1](#)).
- 2 = Analogue input pressure transmitter (CL01.PT01).
- 3 = Analogue input flow transmitter (CW.FT01).
- 4 = Upper reference point analogue input (max. 10V).
- 5 = Value corresponding to upper reference point.
- 6 = Lower reference point analogue input (min. 0V).
- 7 = Value corresponding to the lower reference point.

5.5.3.1 Analogue input building management system

[Figure 24](#) below explains how the analogue input building management system (BMS.CH.AI) works. The analogue input can be used to control the central heating mode based on a 0-10VDC signal. The system detects whether the input is active (input >1V). Between 1V and 2V, the central heating system is not activated, and above 2V, the central heating system is activated, with the central heating setpoint based on the scaling of the analogue input.

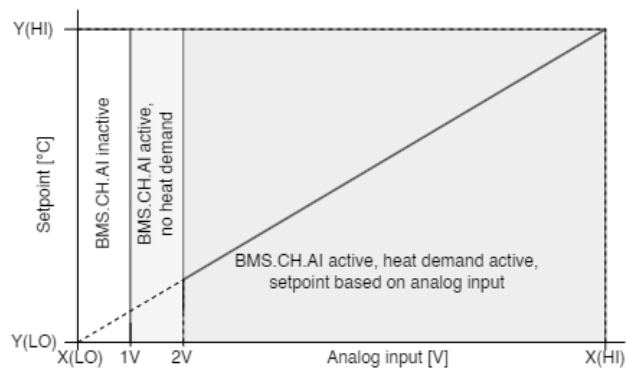

Figure 24 Illustration of an analogue input signal for the building management system

5.5.4 Modbus settings

Modbus settings

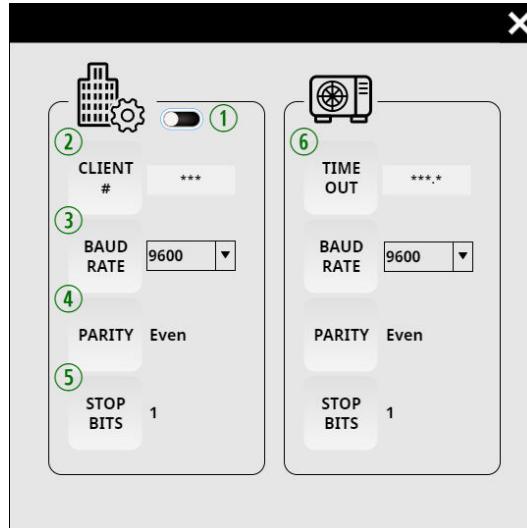

Figure 25

This screen allows you to configure the Modbus settings for the building management system and the heat pump(s). Communication between the BMS and the control system, as well as between the control system and the heat pump(s), is based on an RS485 connection.



Caution

Changing these settings may cause the communication between the BMS and the control system and/or between the control system and the heat pump(s) to fail, rendering the system inoperable.

- 1 = Manually disable control from the BMS.
- 2 = Modbus client address of the control system for the BMS (default 1).
- 3 = Baud rate for communication between the control system and the BMS.
- 4 = Parity for communication between the controller and the BMS.
- 5 = Stop bits for communication between the controller and the BMS.
- 6 = Settings for communication between the controller and the heat pump(s).

For communication between the BMS and the controller, the BMS is the client (master) and the controller is the server (slave). The register list with more information about the available Modbus parameters can be found in [Appendix A.1](#).

For communication between the control system and the heat pump(s), the control system is the client (master) and the heat pump(s) are the servers (slaves). For connecting the heat pumps, see section [4.4.2](#).

5.5.5 Central heating setpoint settings screen

Central heating
setpoint settings
screen

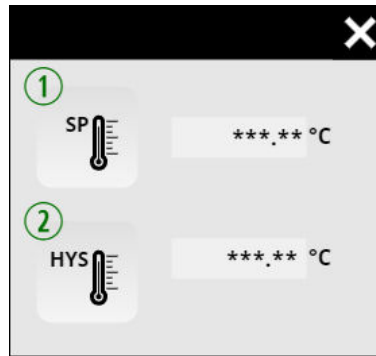

Figure 26

This screen can be used to configure the various setpoint settings for the central heating system.

- 1 = Central heating setpoint. The maximum setting is limited based on the selected heat pump.
- 2 = Central heating switch-on hysteresis.

5.6 Alarm messages

The alarm messages screen displays up to twenty alarm messages and some basic information about these faults. Each error message is also accompanied by a code. This code can be used in [chapter 6](#) to resolve the fault. If the alarm does not have a resolution time in green, this means that it is still active. The most recent alarm message is framed in red.

Alarm messages

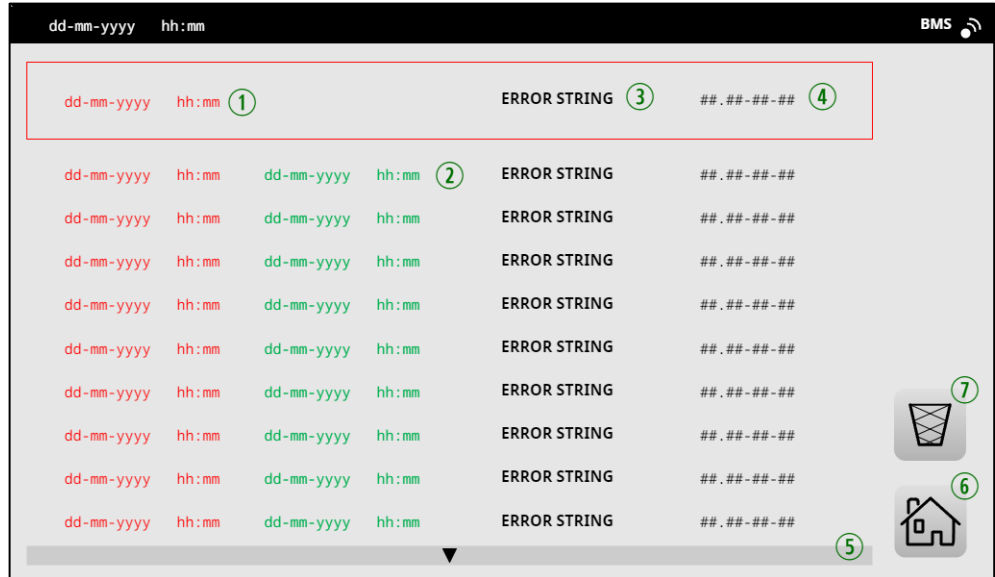

Figure 27

The alarm screen contains the following information:

- 1 = Date and time of alarm occurrence.
- 2 = Date and time when the alarm was resolved.
- 3 = Information about the alarm.
- 4 = Error code.
- 5 = Next page with alarm codes.
- 6 = Return to the home screen.
- 7 = Delete the alarm history.

6 Troubleshooting

Code	Component	Cause	Action
1.1-0-2	TL02.TS01 (T1)	Short-circuited sensor	<p>Check the connection to the temperature sensor and replace if necessary.</p> <p>Check the temperature sensor and replace if necessary.</p>
1.1-0-3	TL02.TS01 (T1)	Open sensor	
1.2-0-2	TL02.TS02 (T2)	Short-circuited sensor	
1.2-0-3	TL02.TS02 (T2)	Open sensor	
1.3-0-2	ST01.TS01 (T3)	Short-circuited sensor	
1.3-0-3	ST01.TS01 (T3)	Open sensor	
1.4-0-2	ST01.TS02 (T4)	Short-circuited sensor	
1.4-0-3	ST01.TS02 (T4)	Open sensor	
1.5-0-2	ST01.TS03 (T5)	Short-circuited sensor	
1.5-0-3	ST01.TS03 (T5)	Open sensor	
1.6-0-2	ST02.TS01 (T6)	Short-circuited sensor	
1.6-0-3	ST02.TS01 (T6)	Open sensor	
1.7-0-2	ST02.TS03 (T7)	Short-circuited sensor	
1.7-0-3	ST02.TS03 (T7)	Open sensor	
1.8-0-2	ST03.TS01 (T8)	Short-circuited sensor	
1.8-0-3	ST03.TS01 (T8)	Open sensor	
1.9-0-2	ST03.TS03 (T9)	Short-circuited sensor	
1.9-0-3	ST03.TS03 (T9)	Open sensor	
1.10-0-2	BT01.TS01 (T10)	Short-circuited sensor	
1.10-0-3	BT01.TS01 (T10)	Open sensor	
1.11-0-2	BT02.TS01 (T11)	Short-circuited sensor	
1.11-0-3	BT02.TS01 (T11)	Open sensor	
1.12-0-2	CL01.TS01 (T12)	Short-circuited sensor	
1.12-0-3	CL01.TS01 (T12)	Open sensor	
2.1-0-1	TL02.CP01	Generic error	<p>Check whether the pump is functioning.</p> <p>Check the cable for the pump alarm signal.</p>
10.x-0-1	CC01.HP0x*	Generic error	Refer to the heat pump documentation for troubleshooting.
10.x-1-3	CC01.HP0x*	Modbus connection open	<p>Check the Modbus connection to the heat pump system.</p> <p>Check that the Modbus settings of the heat pump match the Imperium control.</p> <p>Check whether the heat pump is switched on.</p>
11.y-0-1	CC02.HP0y*	Generic error	Refer to the heat pump documentation for troubleshooting.
11.y-1-3	CC02.HP0y*	Modbus connection open	<p>Check the Modbus connection to the heat pump system.</p> <p>Check that the Modbus settings of the heat pump match the Imperium control.</p> <p>Check whether the heat pump is switched on.</p>
<p>*In the table above, x: a number between 1 and 3 and refers to the corresponding heat pump in cascade CC01 y: a number between 1 and 7 and refers to the corresponding heat pump in cascade CC02</p>			

If this table does not provide a solution, please contact your installer or Lochinvar.

A Appendix

A.1 Modbus register list

The Modbus registers below are available for integration with a building management system (BMS). Communication takes place via RS485 (see 5.5.4). A distinction has been made between write registers, read registers and read registers from the heat pump system. Function code 4x must be used to read parameters and 6x to write them. See www.modbus.org for more information about the Modbus protocol.

Tabel A1: Write registers for control from BMS

Register (dec)	Explanation	Parameter	Type	R / RW	Unit	Register (hex)
2049	Activate BMS control via Modbus	BMS.MB.control	Boolean	RW	Bit 0: 1=active	801
2050	Release DHW (see 3.5.6)	BMS.MB.DHW.release	Boolean	RW	Bit 0: 1=enable	802
2051	DHW user setpoint (see 3.5.6)	BMS.MB.DHW.SP	UInt16	RW	0.01 °C	803
2052	Release central heating (see 3.4.2)	BMS.MB.CH.release	Boolean	RW	Bit 0: 1=enable	804
2053	Central heating setpoint (see 3.4.1)	BMS.MB.CH.SP	UInt16	RW	0.01 °C	805

Tabel A2: Read registers for reading system parameters

Register (dec)	Explanation	Parameter	Type	R / RW	Unit	Register (hex)
2177-2178	Current UTC time of the controller	Current Time	UInt32	R	s	881
2179	Supply temperature from storage tank to plate heat exchanger	TL02.TS01 [T01]	Int16	R	0.01 °C	883
2180	Return temperature from plate heat exchanger to storage tank	TL02.TS02 [T02]	Int16	R	0.01 °C	884
2181	Bottom temperature of DHW storage tank 1	ST01.TS01 [T03]	Int16	R	0.01 °C	885
2182	Average temperature of DHW storage tank 1	ST01.TS02 [T04]	Int16	R	0.01 °C	886
2183	Maximum temperature of DHW storage tank 1	ST01.TS03 [T05]	Int16	R	0.01 °C	887
2184	Bottom temperature of DHW storage tank 2	ST02.TS01 [T06]	Int16	R	0.01 °C	888
2185	Maximum temperature of DHW storage tank 2	ST02.TS03 [T07]	Int16	R	0.01 °C	889
2186	Bottom temperature of DHW storage tank 3	ST03.TS01 [T08]	Int16	R	0.01 °C	88A
2187	Maximum temperature of DHW storage tank 3	ST03.TS03 [T09]	Int16	R	0.01 °C	88B
2188	Buffer tank temperature 1	BT01.TS01 [T10]	Int16	R	0.01 °C	88C
2189	Buffer tank temperature 2	BT01.TS02 [T11]	Int16	R	0.01 °C	88D
2190	Outgoing or recirculation temperature	CL01.TS01 [T12]	Int16	R	0.01 °C	88E
2191	Not in use	-	-	R	-	88F
2192	0-10V Input signal for CH release and CH setpoint	CH.AI (AI02)	UInt16	R	0.01 V	890

Register (dec)	Explanation	Parameter	Type	R / RW	Unit	Register (hex)
2193	0-10V Input signal from pressure transmitter for heat pump hydronic pressure measurement (<i>optional</i>)	TL01.PT01 (AI03)	UInt16	R	0.01 V	891
2194	0-10V Input signal from DHW flow transmitter (<i>optional</i>)	CW.FT01 (AI04)	UInt16	R	0.01 V	892
2195	Not in use	-	-	R	-	893
2196	0-10V control signal for DHW circulating pump	TL02.CP01 (AO02)	UInt16	R	0.01 V	894
2197	Not in use	-	-	R	-	893
2198	0-10V control signal for one-pass regulating valve	TL02.RV01 (AO04)	UInt16	R	0.01 V	896
2199	<u>Status of digital input contacts</u> Bit 0: Status of DHW release contact Bit 1: Status of DHW ECO contact Bit 2: Status of central heating release contact Bit 3: Status of DHW circulation pump alarm contact Bit 4-15: Not in use	Bit 0: DHW.enable (DI01) Bit 1: DHW.ECO.enable (DI02) Bit 2: CH.Enable (DI03) Bit 3: TL02.CP01.alarm (DI04)	UInt16	R	Bit flags	897
2200	<u>Status of digital output contacts</u> Bit 0: Backup heating central heating relay Bit 1: Backup heating DHW relay Bit 2: Booster heating DHW relay Bit 3: Recirculating pump relay Bit 4: Open distributor circulating pump CC01 S/S contact Bit 5: Open distributor circulating pump CC02 S/S contact Bit 6: DHW circulating pump S/S contact Bit 7: Alarm output contact (1 = alarm) Bit 8: Bypass valve TL01: Central heating (0) / DHW (1) Bit 9: Bypass valve TL02: Multi-pass (0) / One pass (1) Bit 10-15: not in use	Bit 0: CH.BH (DO01) Bit 1: DHW.BH (DO02) Bit 2: AH (DO03) Bit 3: CL01.CP01 (DO04) Bit 4: TL01.CP01 (DO05) Bit 5: TL02.CP02 (DO06) Bit 6: TL02.CP01 (DO07) Bit 7: Alarm (DO08) Bit 8: TL01.CV (DO09) Bit 9: TL02.CV (DO10)	UInt16	R	Bit flags	898
2201	Heat pump hydronic pressure measurement (<i>optional</i>)	TL01.PT01	Int16	R	0.01 bar	899
2202	Tap water flow measurement (<i>optional</i>)	CW.FT01	Int16	R	0.01 L/min	89A
2203	System status via UIM	System status	UInt16	R	Bit 0: 0=off/1=on	89B
2204	BMS control manually disabled	UIM control	UInt16	R	Bit 0: 1=active	89C
2205	Control by BMS via Modbus	BMS Modbus control active	UInt16	R	Bit 0: 1=active	89D
2206	Heat pump demand from DHW or central heating	HP heat request	UInt16	R	Bit 0: 1 = request	89E
2207-2209	Not in use	-	-	R	-	89F-8A1
2210	Tap water release via digital input or BMS Modbus control.	DHW enable	UInt16	R	Bit 0: 1=enable	8A2
2211	Tap water setpoint based on DHW user setpoint (internal or from BMS) or ECO setpoint	DHW setpoint	Int16	R	°C	8A3
2212	Setpoint temperature for the multi-pass heating mode (possibly limited by multi-pass envelope limitation)	MP setpoint	Int16	R	°C	8A4

Register (dec)	Explanation	Parameter	Type	R / RW	Unit	Register (hex)
2213	Setpoint temperature for the one-pass heating mode (possibly limited by one-pass envelope limitation)	OP setpoint	Int16	R	°C	8A5
2214	Setpoint for booster heating of DHW	AH setpoint	Int16	R	°C	8A6
2215	Multi-pass or one-pass DHW mode	MP / OP operation	UInt16	R	Bit 0: 0=MP/1=OP	8A7
2216-2219	Not in use	-	-	-	-	8A8-8AB
2220	CH release by DI (thermostat), AI or BMS Modbus control	CH enable	UInt16	R	Bit 0: 1=enable	8AC
2221	Setpoint for CH buffer tank based on internal CH setpoint, CH analogue input, BMS CH setpoint (possibly limited by CH envelope limitation)	CH setpoint	Int16	R	°C	8AD
2222	Calculated percentage based on CH analogue input (CH.AI) 10 %: Not active 10-20%: Analogue input active, but no CH demand 20-90%: CH demand	CH analogue input perc.	Int16	R	0.01 %	8AE
2223	Control of central heating system by analogue input (> 10%)	CH control by analogue input	UInt16	R	Bit 0: 1=active	8AF

Tabel A3: Read registers for reading heat pump parameters of heat pump CC01.HP01

Register (dec)	Explanation	Parameter	Type	R / RW	Unit	Register (hex)
2305	<u>Heat pump 1 status</u> 0=HP off, 1=HP standby, 2=HP starting, 3=Heating, 6=HP stopping, 7=Defrost, 8=Alarm, 9=Anti-freeze	CC01.HP01.State	UInt16	R	-	901
2306	Number of active compressors	CC01.HP01.Compressors	UInt16	R	n	902
2307	Percentage of heat pump capacity	CC01.HP01.Rate	UInt16	R	1%	903
2308-2309	Heat pump operating hours	CC01.HP01.Hours	UInt32	R	1 u	904-905
2310-2312	Not in use	-	-	-	-	906-908
2313	Alarm active	CC01.HP01.Alarm	UInt16		Bit 0: 1=active	909
2314	<u>Refrigerant circuit alarms</u> bit 0: High pressure switch activated bit 1: Compressor discharge pressure too high bit 2: Compressor discharge pressure too low bit 3: Compressor discharge side temperature too high bit 4: Condenser temperature too high bit 5: Not in use bit 6: Low pressure switch activated bit 7: Compressor suction side pressure too high bit 8: Compressor suction side pressure too low bit 9: Compressor suction side temperature too low bit 10: Not in use bit 11: Not in use bit 12: Not in use	CC01.HP01.Alarm.ref	UInt16	R	Bit flags	90A

Register (dec)	Explanation	Parameter	Type	R / RW	Unit	Register (hex)
	bit 13: Overheating too low bit 14: General compressor envelope fault bit 15: Not in use					
2315	<u>System alarms</u> bit 0: Condenser water flow too low bit 1: Condenser water temperature too high bit 2: Condenser water temperature too low bit 3: Not in use bit 4: Not in use bit 5: Not in use bit 6: General antifreeze fault bit 7: General defrost fault bit 8: Refrigerant leak bit 9-15: Not in use	CC01.HP01.Alarm.system	UInt16	R	Bit flags	90B
2316	<u>Hardware alarms</u> bit 0: Overloaded compressor fault bit 1: General compressor fault bit 2: Overloaded fan fault bit 3: General fan fault bit 4: Overloaded pump fault bit 5: General pump fault bit 6: Power supply fault bit 7: General drive fault bit 8: General temperature sensor fault bit 9: General pressure sensor fault bit 10-15 Not in use	CC01.HP01.Alarm.hardware	UInt16	R	Bit flags	90C
2317 - 2320	Not in use	-	-	R	-	90E-910
2321	Heat pump outgoing temperature	CC01.HP01.TS01	Int16	R	0.01 °C	911
2322	Heat pump incoming temperature	CC01.HP01.TS02	Int16	R	0.01 °C	912
2323	Outside temperature	CC01.HP01.TS03	Int16	R	0.01 °C	913
2324-2325	Not in use	-	-	R	-	914-195

For each subsequent heat pump, the registers are the same as in Tabel A3, but with a start register according to Table A4

Tabel A4: Start registers per heat pump

Heat pump:	CC01.HP0x			CC02.HP0y						
	.HP01	.HP02	.HP03	.HP01	.HP02	.HP03	.HP04	.HP05	.HP06	.HP07
Start register (dec):	2305	2433	2561	3329	3457	3585	3713	3841	3969	4097
Start register (hex):	901	981	A01	D01	D81	E01	E81	F01	F81	1000
Offset (dec):	-	+128	+256	+1024	+1152	+1280	+1408	+1536	+1664	+1792

A.2 Electrical scheme

- Brown: 230VAC (L)
- Blue: 230VAC (N)
- Green/Yellow: PE
- Transpart: External voltage!
- Red: 24VDC (L)
- Orange: 24VAC (L)
- White: GND
- Black: DO
- Yellow: DI
- Green: TS
- Grey: AO
- Purple: AI
- RS485 (GND)
- RS485 (-)
- RS485 (+)

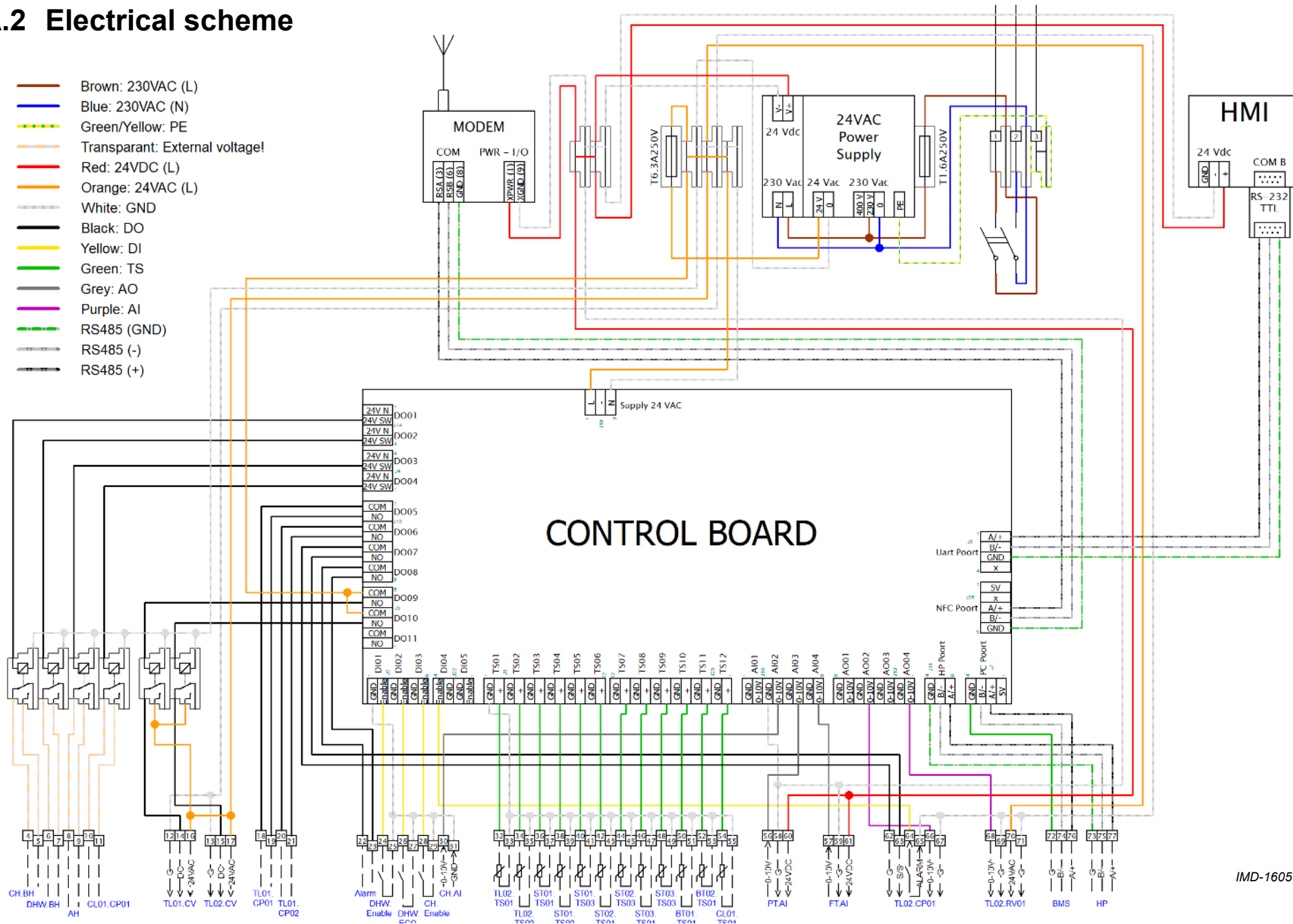

IMD-1605

A.3 Declaration of conformity



Declaration of Conformity

Manufacturer: Lochinvar Limited
8 Lombard Way
The MXL Centre
Banbury - United Kingdom

hereby declares that the following products:

Product description: Control for Heat Pump Systems
Product family name: IMPERIUM
Product models: IMP LAHP

on the assumption that the installation instructions have been followed are compliant to:

Low Voltage Directive (LVD) - 2014/35/EU

Requirements for Restriction of Hazardous Substances (RoHS II/III) Directive - 2011/65/EU en 2015/863/EU

Company:
Lochinvar Limited

Date:
May 1, 2025

Signature:

T. van der Hamsvoort
Managing Director

A.4 Warranty

Article 1: Warranty

If within 2 (two) years of the commissioning date of an Imperium controller supplied by Lochinvar Ltd., following verification, and at the sole discretion of Lochinvar Ltd., the unit or components within the unit proves to be defective or fails to function correctly due to manufacturing and/or material defects, then Lochinvar Ltd. shall repair or replace this assembly or part.

Article 2: Ancillary Options

The Imperium controller may be supplied with additional ancillary components such as 2 port valves, these are subject to their own warranty of 12 months.

Article 3: Conditions for installation and use

The warranty set out in articles 1 and 2 will apply solely under the following conditions:

- a. The Imperium is installed under strict adherence to Lochinvar Ltd. installation instructions for the specific model and must be in accordance with the Requirements for Electrical Installations, IET Wiring Regulations, Eighteenth Edition, BS 7671:2018+A2:2022. All work must be undertaken by a competent electrical engineer.
- b. The Imperium remains installed at the original site of installation.

Article 4: Exclusions

Service parts and consumables are not included within the above warranty period, this includes (but is not limited to) any part identified within the Installation manual which should be changed as part of the service regime for the appliance. These parts have a 12-month warranty from the date of commissioning or from the date of delivery to site. The warranty set out in articles 1 and 2 will not apply in the event of:

- a. damage to the Imperium caused by an external factor.
- b. misuse, neglect (including frost damage), modification and incorrect and/or unauthorized use of the Imperium.
- c. contaminants or other substances having been allowed to enter the Imperium.
- d. any attempts at repair to a defective Imperium unit other than by an approved service engineer.

Article 5: Scope of the warranty

The obligations of Lochinvar Ltd. pursuant to the specified warranty are limited to free delivery from the warehouse of the replacement assemblies, parts, or water heater, respectively. Labour, installation, and any other costs associated with the replacement will not be accepted by Lochinvar Ltd.

Claims:

A claim on grounds of the specified warranty must be submitted to the dealer from whom the Imperium was purchased, or to another authorized dealer of Lochinvar Ltd. Inspection of the Imperium as referred to in articles 1 and 2 shall take place in one of the laboratories of Lochinvar Ltd.

Obligations of Lochinvar Ltd.:

Lochinvar Ltd. grants no other warranty or guarantee over its Imperium nor the (assemblies or parts of) Imperium supplied for replacement, other than the warranty expressly set out in these conditions. Under the terms of the supplied warranty, Lochinvar Ltd. is not liable for damage to persons or property caused by (assemblies or parts) of a (replacement) water heater that it has supplied.



Lochinvar®

8 Lombard Way
The MXL Centre, Banbury
Oxon, OX16 4TJ

+44 (0) 1295 269 981
info@lochinvar.ltd.uk
www.lochinvar.ltd.uk

Lochinvar Ltd reserves the right to change specifications without prior notice