

# TECHNICAL PRODUCT SUBMITTAL

## EcoKnight EKW206CE



### TECHNICAL DATA

Nominal Input (net)	kW	184.9
Nominal Input (gross)	kW	205.2
Gas Flow Rate (natural gas)	m3/hr	19.6
Nominal Output	kW	187.4
<b>EFFICIENCY DATA-Part L2</b>		
Heat generator seasonal efficiency	%	91.3
Effective heat generator seasonal efficiency *	%	93.8
<b>EFFICIENCY DATA-ErP and Energy Label</b>		
Ecodesign Energy Label rating		n/a
Seasonal space heating energy efficiency	%	95
<b>GENERAL DATA</b>		
NOx emission @0% O2	mg/kWh	34
Recovery Rate @ 44°C	l/hr	3865
Recovery Rate @ 50°C	l/hr	3401
Recovery Rate @ 56°C	l/hr	3037
Dimensions (height )	mm	1080
Dimensions (width)	mm	395
Dimensions (depth)	mm	1024
Water Content	litres	18.9
Weight (empty)	kg	168
Weight (full)	kg	187
Flow Connection (inches)	BSP	2
Return Connection (inches)	BSP	2
Gas Connection (inches)	BSP	1
Electrical Requirements		230V /1Ph/ 50hz
Power Consumption	W	322
Sound Power Level	LWA(db)	69
Maximum Flue Gas Temperature	°C	120
Max Outlet Temperature	°C	88
Maximum Working Pressure	bar	11

\* The effective heat generator seasonal efficiency is the heat generator seasonal efficiency plus heating efficiency credits gained by adopting additional measures from Table 31 of the non-domestic compliance guide.

1. Fully automatic ignition controls 0.5%
2. Correct sizing of unit confirmed using manufacturers technical helpline and sizing software 2%

**EcoKnight water heaters** must be installed and maintained in line with the Installation Commissioning and Maintenance Instructions which are available on the Literature & Downloads section of [www.lochinvar.ltd.uk](http://www.lochinvar.ltd.uk)

Particular attention should be made to:-

- Correct sizing of associated buffer vessel
- Dimensions and clearances
- Vented and Unvented installation requirements
- maintenance

#### **ErP and Warranty**

ErP Data including Product Fiche and Energy Labels where applicable and Warranty information are also available at [www.lochinvar.ltd.uk](http://www.lochinvar.ltd.uk)

# TECHNICAL PRODUCT SUBMITTAL

## EcoKnight EKW206CE

### DIMENSIONS AND CONNECTIONS

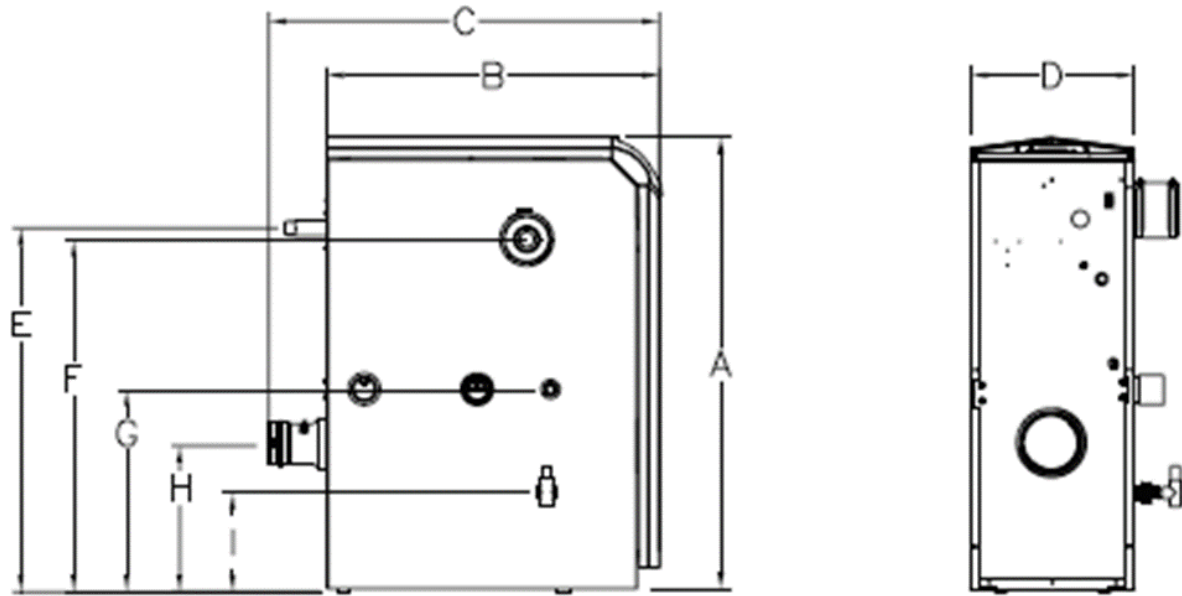

Description			EKW116CE	EKW146CE	EKW176CE	EKW206CE	EKW236CE
A	Height	mm	1080	1080	1080	1080	1080
B	Depth	mm	688	798	925	1024	1153
C	Depth inc Flue Outlet	mm	828	938	1065	1164	1293
D	Width	mm	395	395	395	395	395
E	Gas Connection	mm	860	887	833	833	834
F	Air Inlet	mm	860	887	915	915	915
G	Water Connections	mm	477	477	477	477	477
H	Flue Outlet	mm	350	350	350	350	350
I	Condense Outlet	mm	230	230	230	230	230

Connection Sizes			EKW116CE	EKW146CE	EKW176CE	EKW206CE	EKW236CE
E	Gas Connection	BSP	1"	1"	1"	1"	1"
F	Air Inlet	mm	100	150	150	150	150
G	Water Connections	BSP	2"	2"	2"	2"	2"
H	Flue Outlet	mm	100	150	150	150	150
I	Condense Outlet	PVC	½"	½"	½"	½"	½"

# TECHNICAL PRODUCT SUBMITTAL

## EcoKnight EKW206CE



### PRIMARY PIPEWORK SIZING AND MATCHED CIRCULATING PUMPS

Lochinvar will offer a matched primary pump, which is sized on the flow rate, and pressure drop as shown in table 1 and pipework sized according to table 2 below. The calculated pressure drop and pump selection is based on:

- maximum total flow/return pipework is no more than 14 metres
- maximum 4no 90 bends
- 3 fully ported isolating valves per water heater

If the system design is outside these parameters it is the installers/specifiers responsibility to check the pump will be suitable using the pump curves shown in table 3. Also shown is the pump curve for a larger alternative pump, which may be suitable. **Please ensure the correct pump is chosen.**

TABLE 1 FLOW RATE AND PRESSURE DROP

Data			
Water heater model	delta t	Flow rate l/sec	Pressure drop kPa
EKW46CE	10	0.98	72
EKW61CE	10	1.59	66
EKW86CE	10	2.27	69
EKW116CE	10	3.18	93
EKW146CE	10	4.01	78
EKW176CE	10	4.01	78
EKW206CE	10	4.77	96
EKW236CE	10	5.07	93

TABLE 2 PIPEWORK SIZING

MODEL	PIPEWORK A BLUE SIZE (mm)		PIPEWORK B RED SIZE (mm)	
	NUMBER OF ECOKNIGHT™			
	1	2	3	4
EKW116CE	54	67	108	108
EKW146CE	54	76	108	108
EKW176CE	54	76	108	108
EKW206CE	54	108	108	108
EKW236CE	54	108	108	108

DRAWING 1 SINGLE EKW AND VESSEL

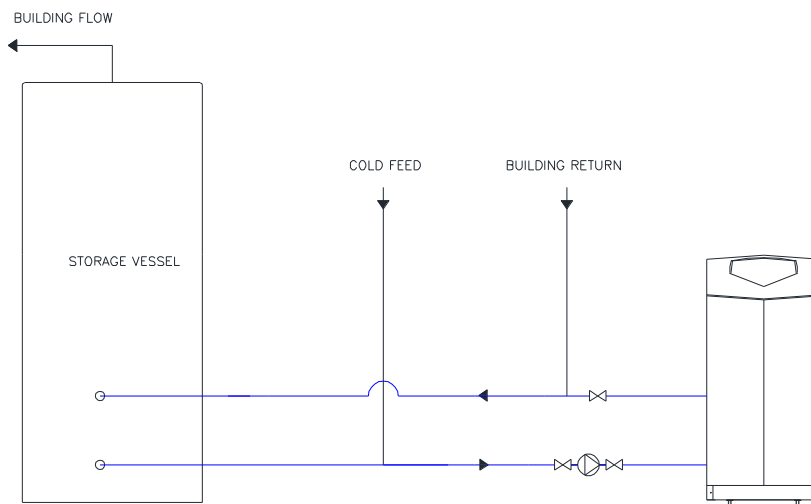

# TECHNICAL PRODUCT SUBMITTAL

## EcoKnight EKW206CE

DRAWING 2 MULTIPLE EKW AND VESSEL(S)

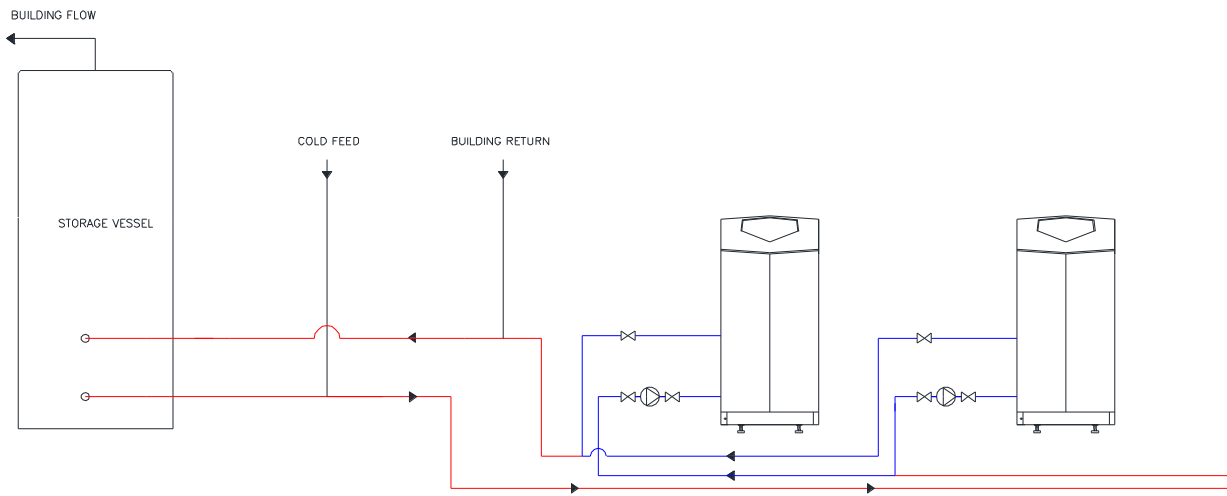

In general, the standard pump will be suitable for a single unit and vessel, multiple water heaters and/or multiple vessels will require the alternative pump.

TABLE 3 PUMP CURVES

LM900334A STANDARD PUMP, CURVE

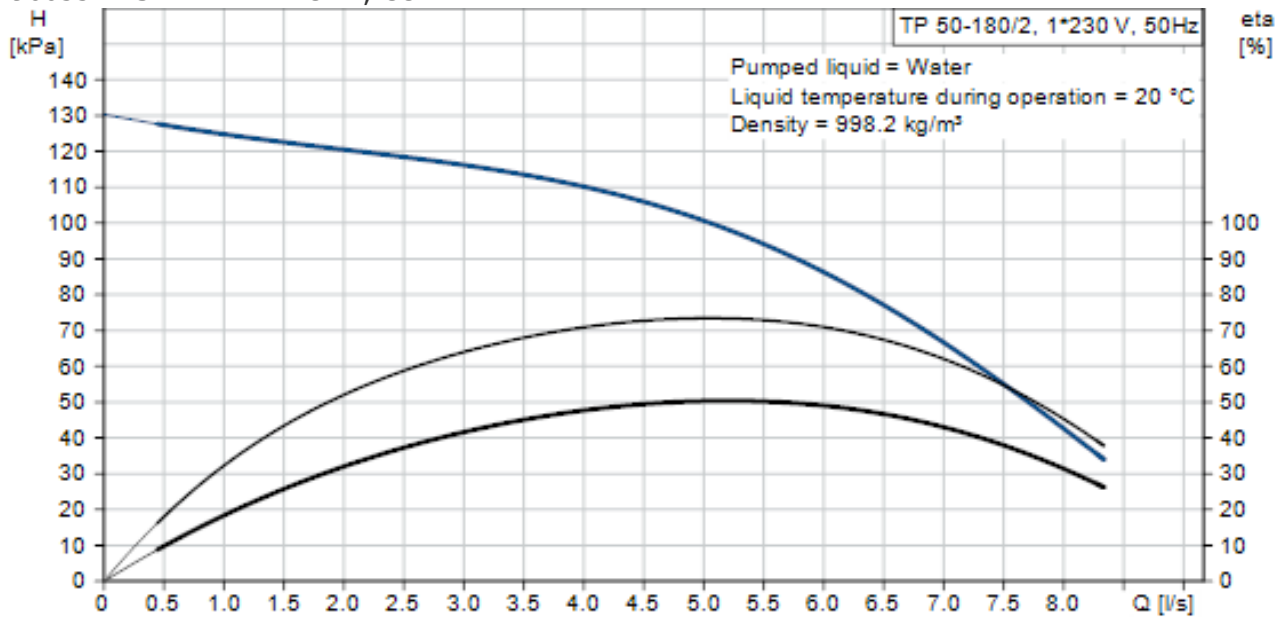

# TECHNICAL PRODUCT SUBMITTAL

## EcoKnight EKW206CE



LM900378A ALTERNATIVE HIGH HEAD PUMP, CURVE

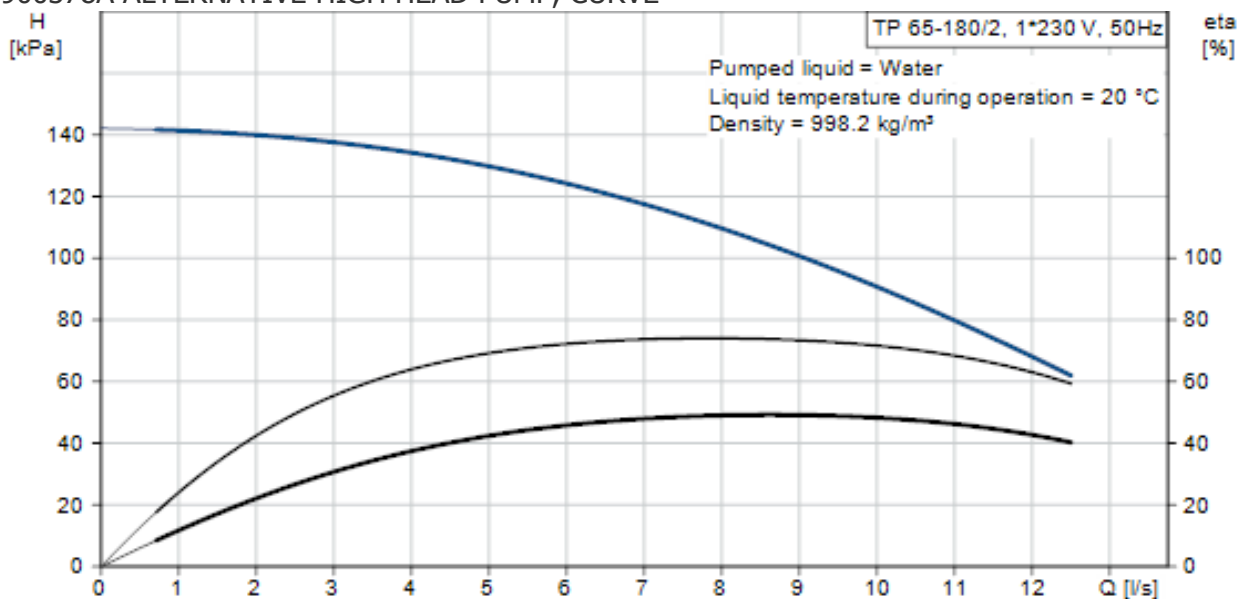

### WIRING AND CONTROL

EcoKnight water heaters come complete with the following standard controls:

- Primary pump control

DRY CONTACTS PROVIDED				
 PRIMARY C N/O	 DE-STRAT C N/O	 RETURN C N/O	 230V~50Hz MAINS L N	 100285312 REV A
MAX 25 AMPS PER REPLAY				

CONNECTION	OUTPUT	NOTES
PRIMARY	25 Amp relay	The pump terminals on these models are provided as a set of "dry contacts" which are switched via a set of 25Amp relays. You will need to apply 230v power to the common terminal and connect the normally open terminal to the live of the target pump.
DE-STRAT	NO OUTPUT	CONNECTION NOT USED
RETURN	25 Amp relay	The pump terminals on these models are provided as a set of "dry contacts" which are switched via a set of 25Amp relays. You will need to apply 230v power to the common terminal and connect the normally open terminal to the live of the target pump.
MAINS		Connections for a 230V ~ 1 ph 50Hz power supply. <b>NOTE:</b> The power supply cable should be secured using the anchor supplied.



# TECHNICAL PRODUCT SUBMITTAL

## EcoKnight EKW206CE

- Vessel temperature sensor and water heater activation

In order for the water heater to work correctly the vessel sensor supplied with every water heater must be installed within the storage vessel at point 7 as shown in drawing 3 below. When installing multiple water heaters only one vessel sensor is required, wired back to the cascade leader with all other water heaters wired back to the leader. When a hot water demand is detected the cascade lead will decide how many water heaters to activate to maintain set point, the cascade leader will also rotate which water heater is activated first to share running hours between the whole cascade. A second water heater can be programmed to take over from the cascade leader should the cascade leader suffer from an electrical failure, when the cascade leader is repaired the alternate lead will relinquish control back to the cascade leader.

DRAWING 3

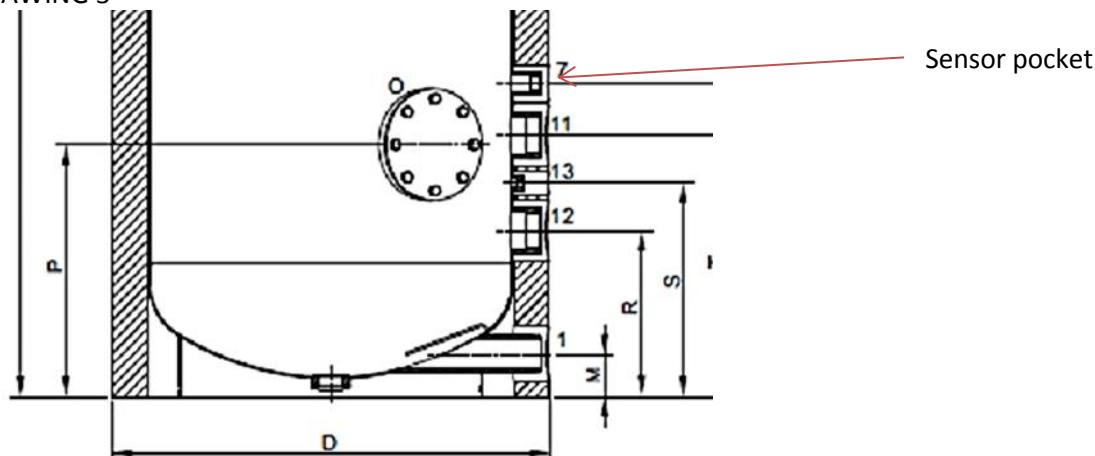

- Cascade control
- Remote on/off
- Fault signal

### WATER QUALITY REQUIREMENTS

Water supply quality may adversely affect the efficiency performance and longevity of Water Heaters and Hot Water systems. Hard water may cause the formation of limescale that will reduce operating efficiency and may cause early product failure. Please note the following: -

- Water Hardness – should not exceed 205ppm CaCO<sub>3</sub> and Total Dissolved Solids (TDS) of untreated water should not exceed 350ppm.

**If these values are exceeded a water treatment specialist should be consulted. Water Softeners and Water Conditioners may be considered, but whichever method is selected, it should be suitable for installation with Direct Gas-fired Water Heaters. A maintenance regime will also be required for such systems**

**•High hot water temperature and high demand for hot water is likely to cause quicker limescale formation**  
**The formation of limescale or other solids can cause a blockage within the heat exchanger, which in turn may cause premature failure. Such instances are not regarded as defects in manufacture and will not be covered under the product warranty.**