

EcoShield storage-type gas-fired water heaters



- Hot water recovery rates from 612 to 2436 l/hr at 50°C temperature rise
- Fully modulating pre-mix burner
- Efficiencies of up to 96.45%
- Low NO_x emissions ≤40mg/kWh
- 5-year storage vessel warranty
- 10 bar working pressure

EcoShield water heaters

EcoShield fully condensing gas-fired water heaters are available in 6 models with hot water recovery rates from 612 to 2436 litres/hour based upon a temperature rise of 50°C. These units are designed on the principle of low hot water storage but fast recovery, and are suitable for many commercial and industrial applications. With efficiencies of up to 96.45% (building regulations gross CV) and NO_x emissions as low as 26mg/kWh, EcoShield water heaters can reduce energy consumption and carbon emissions.



EcoShield water heater
6 models available

Product features

- Fully modulating pre-mix burner with 5:1 turndown
- Stainless steel heat exchanger
- Integral A-rated shunt pump
- Suitable for unvented or open vented hot water systems
- CFC-free foam insulation – which reduces standing losses
- Available for natural gas or LPG

Stainless steel heat exchanger

At the heart of the EcoShield Water Heater is a grade 316l stainless steel heat exchanger. This material provides superior resistance to corrosion. The coiled design of the heat exchanger allows for condensation to occur, creating high efficiency, particularly on initial heat up.



EcoShield heat exchanger

Integral storage

The hot water generated in the heat exchanger is transferred to the integral storage vessel via the A-rated shunt pump and inter-connecting pipework. Storage capacities range from 248 to 424 litres. The storage vessel is constructed from high quality enamelled steel, and includes a cleanout opening.

The storage vessel is supported with a 5-year warranty against leakage.

Ease of maintenance

Access to the heat exchanger, burner and controls is from the front of the unit, and provides for ease of maintenance. On the water side cathodic protection is provided by 2 horizontally installed magnesium anodes. Again this allows for easy inspection and replacement if necessary. A correx non-sacrificial anode protection system is available as an ancillary option.

Advanced electronic control

The integral control is easy to navigate and provides information on water heater status, as well as providing detailed diagnostic information.

Also included are:

- Contacts for connection to BMS
- Programmer/setback facility
- Adjustable pump delay



EcoShield water heater internal view

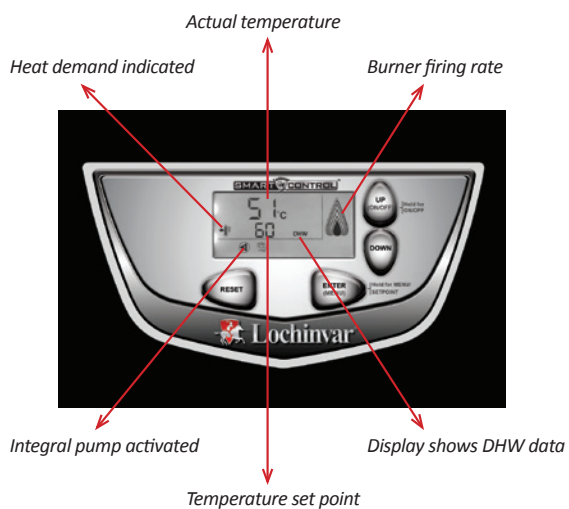

Dimensional drawings

Water heater model	Height (Mm)	Diameter (Mm)	T&P valve (mm)	Condense trap (Mm)	Cold feed (mm)	Hot outlet (mm)
	A	B	C	D	E	F
SHW35-245CE	1568	714	755	1144	1610	1610
SHW46-325CE	1924	714	1117	1503	2005	2005
SHW61-325CE	1927	714	1126	1517	2005	2005
SHW86-410CE	1922	865	786	1248	2020	2020
SHW116-410CE	1922	865	786	1248	2020	2020
SHW146-410CE	1922	865	786	1248	2020	2020

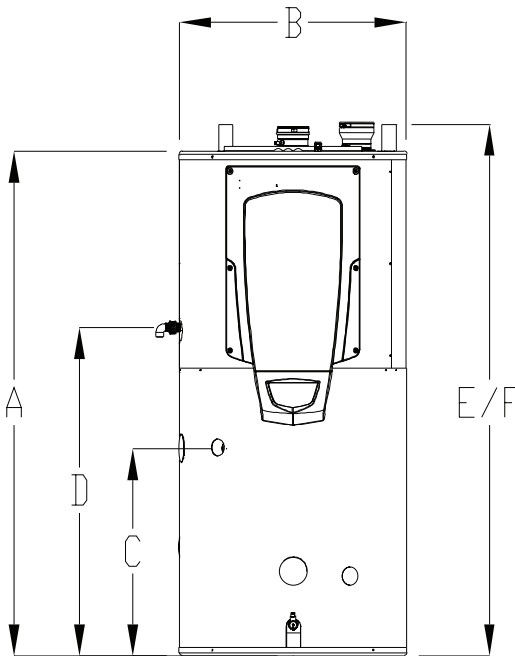

Siting flexibility

The EcoShield requires minimal clearances shown below, and as a result can be installed in compact spaces.

- Top: 450mm
- Left: 600mm
- Right: 100mm
- Front: 600mm
- Rear: zero

Flue options

EcoShield water heaters can be installed with horizontal or vertical concentric flue, twin pipe (parallel) balanced flue or conventional flue.

Horizontal and vertical concentric flue

Water Heater Model	Diameter (mm)	Max. length (m)	Reduction for 90° bend (m)	Reduction for 45° bend (m)
SHW35-245CE	80/125	30	1	0.5
SHW46-325CE	80/125	30	1	0.5
SHW61-325CE	80/125	30	1	0.5
SHW86-410CE	100/150	30	1	0.5
SHW116-410CE	100/150	30	1	0.5
SHW146-410CE	100/150	13	1	0.5

Twin pipe flue

Water heater model	Diameter (mm)	Max. total length (m)	Reduction for 90° bend (m)	Reduction for 45° bend (m)
SHW35-245CE	80	60	1	0.5
SHW46-325CE	80	60	1	0.5
SHW61-325CE	80	60	1	0.5
SHW86-410CE	100	60	1	0.5
SHW116-410CE	100	60	1	0.5
SHW146-410CE	100	60	1	0.5

Conventional flue

Water heater model	Diameter (mm)	Max. total length (m)	Reduction for 90° bend (m)	Reduction for 45° bend (m)
SHW35-245CE	80	60	1	0.5
SHW46-325CE	80	60	1	0.5
SHW61-325CE	80	60	1	0.5
SHW86-410CE	100	60	1	0.5
SHW116-410CE	100	60	1	0.5
SHW146-410CE	100	60	1	0.5

Technical specification

Water heater model		SHW35-245CE	SHW46-325CE	SHW61-325CE	SHW86-410CE	SHW116-410CE	SHW146-410CE
Nominal input (nett)	kW	33.3	39.6	55.4	75.2	105.3	132.0
Nominal input (gross)	kW	36.6	44.0	61.5	83.5	116.9	146.5
Gas flow rate (natural gas)	m ³ /hr	3.50	4.20	5.70	8.00	11.10	14.00
Nominal output	kW	35.2	41.2	58.7	79.7	110.6	141.2
Efficiency Data - Building Regulations							
Seasonal efficiency (gross CV)	%	96.2	93.6	95.8	96.0	94.6	96.4
Maintenance consumption value	MJ/M	302	302	302	302	302	302
Efficiency data - ErP and energy label							
Ecodesign energy label rating		B	B	B	n/a	n/a	n/a
Water heater efficiency	%	76	73	81	79	78	79
NO_x Emissions							
NO _x @0%O ₂ according to EU regulation 812/2013	mg/kWh	26	33	27	33	40	38
General data							
Recovery rate @ 44°C	l/hr	695	806	1153	1567	2164	2768
Recovery rate @ 50°C	l/hr	612	709	1014	1379	1904	2436
Recovery rate @ 56°C	l/hr	546	633	905	1231	1700	2175
Dimensions (height)	mm	1530	1920	1920	1920	1920	1920
Dimensions (diameter)	mm	715	715	715	865	865	865
Storage capacity	litres	248	331	332	420	423	424
Weight (empty)	kg	136	281	290	379	388	406
Weight (full)	kg	384	614	625	825	838	860
Hot outlet connection (copper pipe)	mm	42	42	42	54	54	54
Cold feed connection (copper pipe)	mm	42	42	42	54	54	54
Gas connection (inches)	BSP	½"	½"	½"	¾"	1"	1"
Flue connection (concentric)	mm	80/125	80/125	80/125	100/150	100/150	100/150
Flue connection (twin-pipe)	mm	80	80	80	100	100	100
Electrical requirements		230V /1Ph/ 50hz					
Power consumption (peak)	W	361	431	459	646	932	961
Sound power level	LWA(db)	56	58	60	62	64	66
Maximum flue gas temperature	°C	120	120	120	120	120	120
Max outlet temperature	°C	80	80	80	80	80	80
Maximum working pressure	bar	10	10	10	10	10	10

Energy label, product fiche and ErP data table are available at www.lochinvar.ltd.uk

Ancillary options

- Unvented system kits
- Concentric and twin pipe flue assemblies
- Conventional flue adaptor
- Correx non-sacrificial anode system (factory fitted)
- Condensate neutralisation kit

For further information on the EcoShield™ water heater, including ICM & user instructions and our full warranty terms and conditions, please visit our website: www.lochinvar.ltd.uk

