

# CPM, CPMSP Cascade header kits Installation, Commissioning and Maintenance Instructions

CPM58  
CPM77  
CPM96  
CPM116  
CPMSP116  
CPM144  
CPM175



# INDEX

<b>1. INTRODUCTION</b> .....	<b>3</b>
<b>2. MAIN DIMENSIONS</b> .....	<b>4</b>
2.1 Cascade dimensions. The picture shows connecting sets for CPM boilers – for CPM SP boilers the connecting sets are different. ....	4
2.2 Cascade Dimensions (use in conjunction with 2.1) .....	5
<b>3. EXPLANATION OF PARTS AND GROUPS</b> .....	<b>6</b>
3.1 Cascade parts and groups. For the CPM/ CPM SP boilers, the return connecting sets for the CPM are different to the CPM SP range. ....	6
<b>4. FRAME GROUPS</b> .....	<b>7</b>
4.1 Cascade frame groups for 1, 2, 3, and 4 boilers. ....	7
4.2 Frame group parts (use in conjunction with 4.1) .....	8
<b>5. MOUNTING THE BOILERS ON THE FRAME</b> .....	<b>9</b>
5.1 Mounting details.....	9
<b>6. MOUNTING THE CONNECTING SETS</b> .....	<b>10</b>
6.1 Connecting sets. ....	10
<b>7. MOUNTING THE HYDRAULIC GROUP</b> .....	<b>12</b>
7.1 Hydraulic group for 2 boilers CPM 58–116 and/or CPM SP .....	13
7.2 Hydraulic groups for 3 and 4 boilers CPM 58–116 and/or CPM SP .....	14
7.3 Hydraulic groups for 2 and 3 boilers CPM 144–175.....	15
7.4 Hydraulic group for 4 boilers CPM 144–175.....	16
<b>8. LOW VELOCITY HEADERS</b> .....	<b>17</b>
<b>9. PLATE SEPARATORS</b> .....	<b>18</b>
<b>10. FLUE GAS AND AIR SUPPLY</b> .....	<b>19</b>
10.1 Individual or common flue systems .....	19
10.2 Individual flue systems.....	19
10.3 Common flue systems .....	19
<b>11. INSTALLATION</b> .....	<b>20</b>
<b>12. CASCADE CONTROL</b> .....	<b>20</b>
12.1 Output control .....	20
12.2 Boiler sequence .....	20
<b>13. OPTIONS</b> .....	<b>21</b>

# 1. Introduction

This Installation manual should be read in conjunction with the installation (ICM) manual for either the CPM gas-condensing boiler or the CPM SP cascade system boiler. If you do not have a copy of the ICM, it can be downloaded at [www.lochinvar.ltd.uk](http://www.lochinvar.ltd.uk)

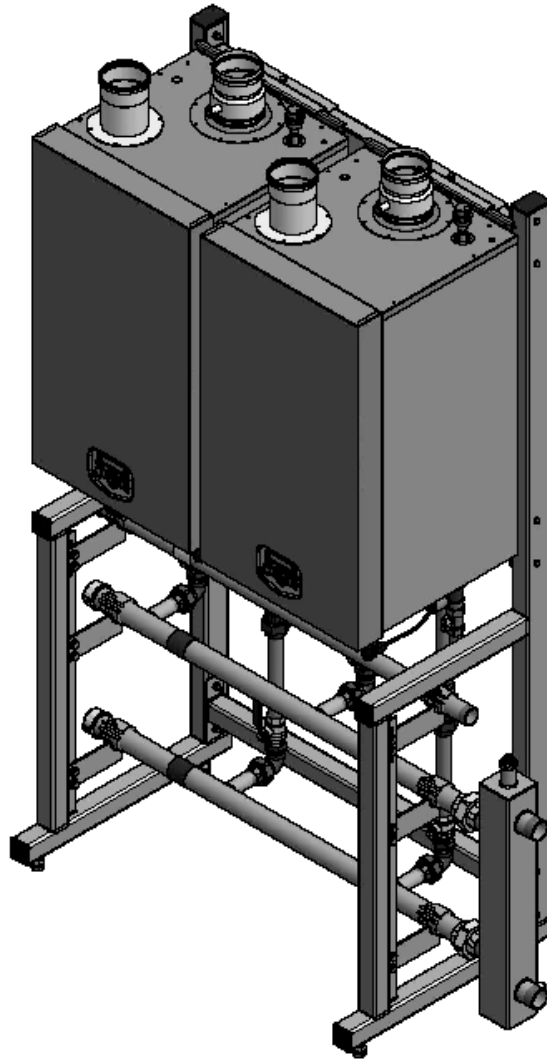

**Figure 1. Typical cascade configuration.**

This Cascade manual is for use with the CPM and CPM SP wall-hung high efficiency condensing boilers manufactured by Lochinvar Limited. These boilers are available, in order of ascending output, as CPM 58, CPM 77, CPM 96, CPM 116, CPM 144, CPM 175 and CPM SP Range.

The CPM 58-116 boilers can be supplied in one cascade set, as can the CPM 144-175 boilers; due to their size difference, they cannot be mixed. Lochinvar Limited can supply standard cascade systems with mounting frame, piping and low loss headers for up to four boilers.

All CPM boilers are equipped as standard with an internal cascade manager for up to twelve boilers. No extra controllers are necessary; you only connect a 2-wire cable between all boilers.

The low-loss header can be fitted on the right-hand side as well as on the left-hand side without altering the pipework. The gas connection can be fitted on one of both sides, independently from the side chosen for the low loss header. To commission the cascade installation, it is necessary to set a number of parameters on the boilers, see boiler ICM.

## 2. Main dimensions

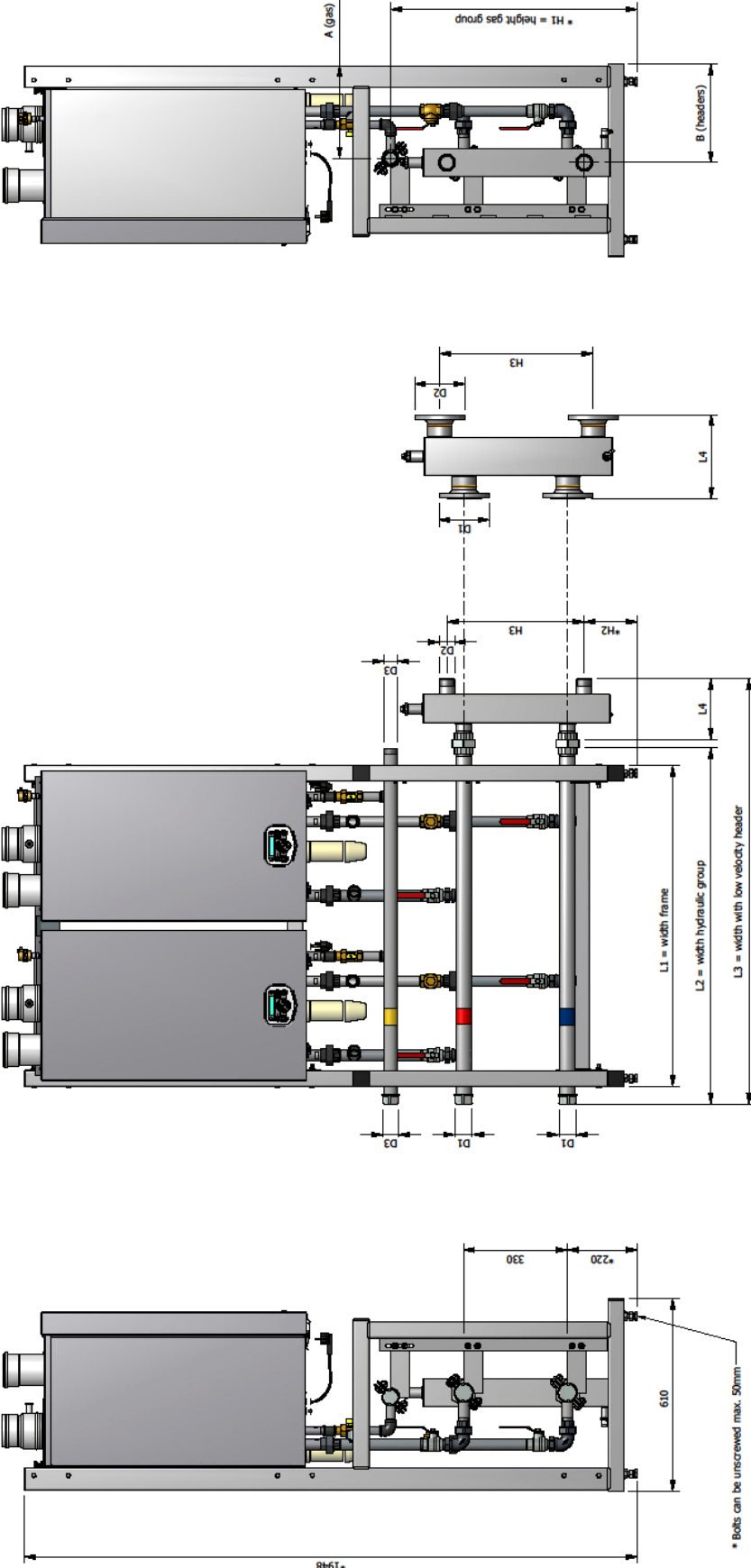

2.1 Cascade dimensions. The picture shows connecting sets for CPM boilers – for CPM SP boilers the connecting sets are different.

<b>CPM 58 -116 and CPMSP</b>		<b>2 boilers</b>	<b>3 boilers</b>	<b>4 boilers</b>
L1 (frame)	1015	1520	1980	
L2 (standards)	1140	1630	2084	
L3 (total)	1358	1914	2393	
L4 (open header)	190	265	290	
H1 (gas)	787	789	791	
H2 (open header)	766	766	768	
H3 (open header)	436	487	440	
D1 (Connection)	RP 1½"	DN 65 PN6 (2½")	DN 80 PN6 (3")	
D2 (Connection)	R 1½"	DN 65 PN6 (2½")	DN 80 PN6 (3")	
D3 (gas)	R 1¼"	R 1½"	R 2"	
A (gas)	271	283	283	
B (headers)	283	283	283	
<b>CPM 144 -175</b>		<b>3 boilers</b>	<b>4 boilers</b>	
L1 (frame)	1015	1520	1980	
L2 (standards)	1125	1630	2090	
L3 (total)	1408	1940	2465	
L4 (open header)	265	290	355	
H1 (gas)	766	766	768	
H2 (open header)	144	165	168	
H3 (open header)	487	440	440	
D1 (Connection)	DN 65 PN6 (2½")	DN 80 PN6 (3")	DN 96 PN6 (4")	
D2 (Connection)	DN 65 PN6 (2½")	DN 80 PN6 (3")	DN 96 PN6 (4")	
D3 (gas)	R 2"	R 2"	DN 80 (3")	
A (gas)	338	338	338	
B (headers)	283	283	283	

**2.2 Cascade Dimensions (use in conjunction with 2.1)**

### 3. Explanation of parts and groups

Each cascade set exists of the following parts and groups:

1. Two to four CPM/CPM SP boilers.
2. The frame group (with locking plates) as determined by the number of boilers.
3. Connecting groups to connect the boilers to the hydraulic groups (one group for each boiler, each group consists of one gas, one flow and one return connecting set).
4. Hydraulic group, of one gas, one flow and one return header with all fixing and connecting parts.
5. Low-loss header or hydraulic separation plate heat exchanger.(plate would be supplied loose)

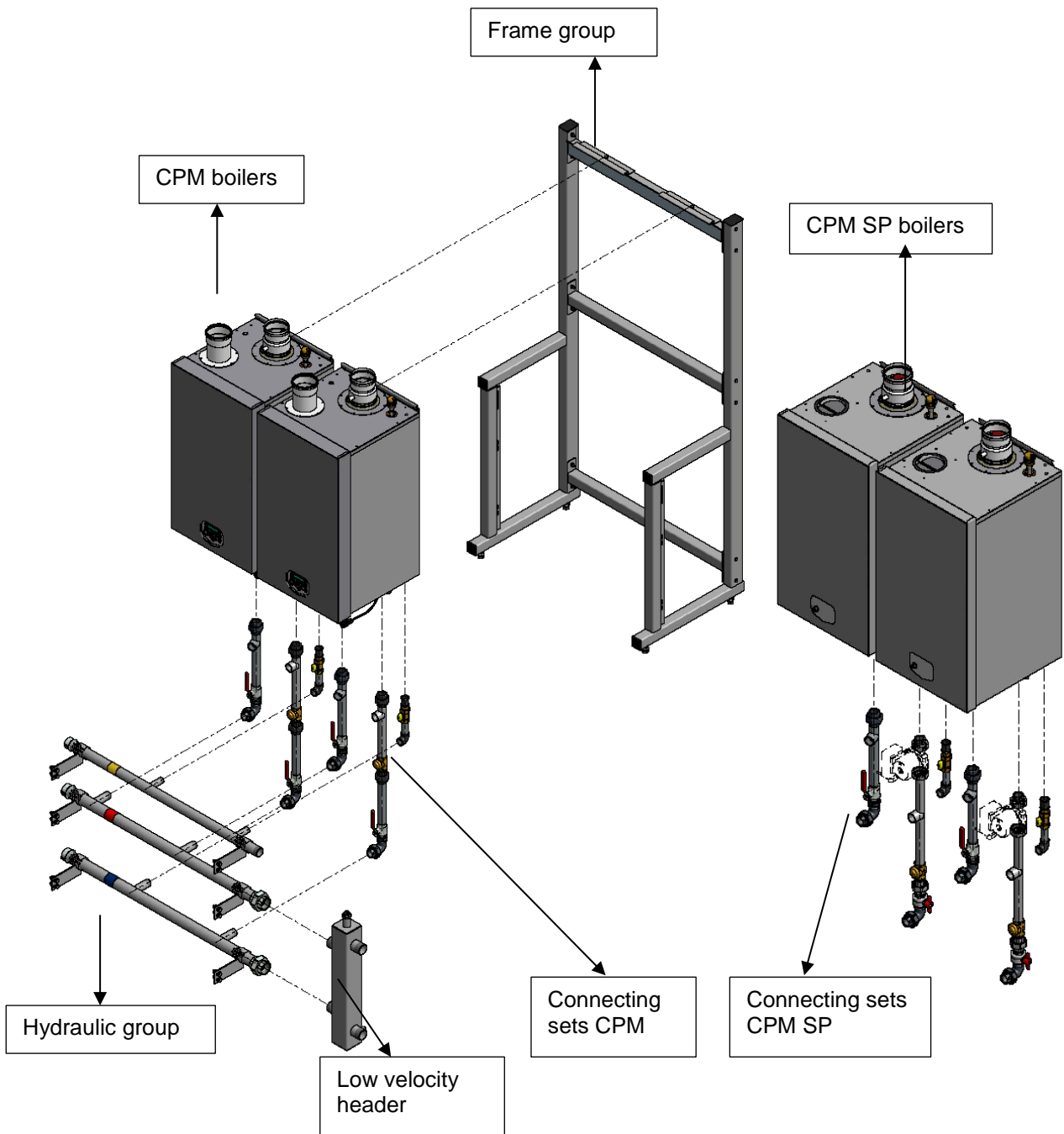

#### 3.1 Cascade parts and groups. For the CPM/ CPM SP boilers, the return connecting sets for the CPM are different to the CPM SP range.

# 4. Frame groups

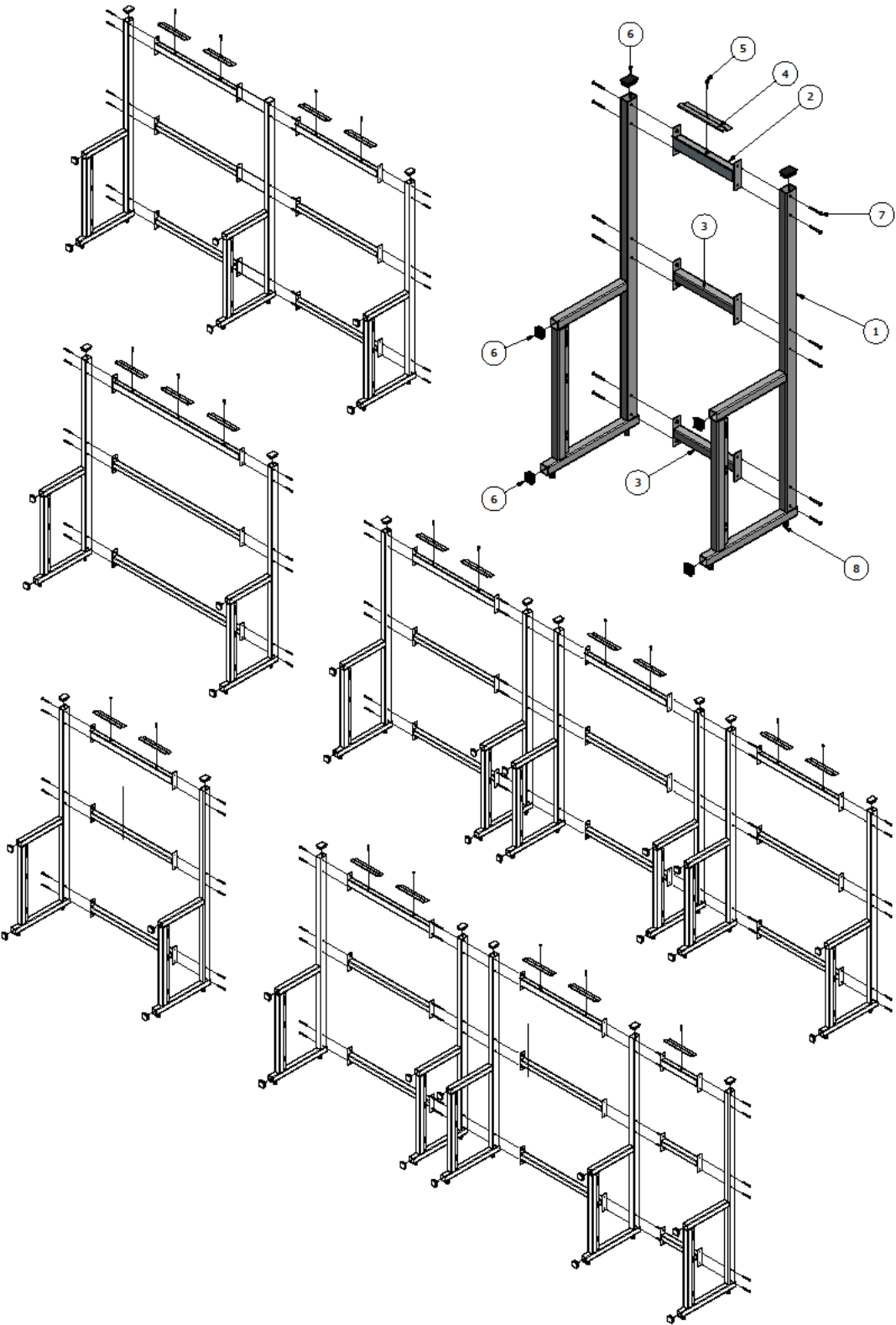

4.1 Cascade frame groups for 1, 2, 3, and 4 boilers.

Item Number	Description	2 Boiler mounting frame	3 Boiler mounting frame	4 Boiler mounting frame
		Quantity	Quantity	Quantity
1	standard	2	2	3
2	upper beam	1	1	2
3	mid/lower beam	2	2	4
4	locking plate	2	3	4
5	lock bolt M8 x 35	2	3	4
6	seal plug 70mm x 50mm	2	2	3
	seal plug 50mm x 50mm	4	4	6
7	bolt M8 x 70	12	12	18
	nut M8	12	12	18
	washer M8	14	15	22
8	adjusting bolt standard M16 x 80	4	4	6

#### 4.2 Frame group parts (use in conjunction with 4.1)



## 5. Mounting the boilers on the frame

All lines/piping must be mounted free of tension. The weight of all the components must be supported separately from the boiler so there is no force on the connections. This might influence the mounting position of the boiler.

Before mounting the boiler on the frame, ensure that the frame is level in both directions. If necessary adjust with the adjusting bolts on the lower side of the frame (see drawing).

After mounting the boiler on the frame, ensure that the boiler is level. If necessary, adjust with the adjusting bolts on the lower rear side of the back panel. (See drawing).

When the adjusting bolts are not sufficient, it may be necessary to fill behind the bolts to get the boiler level. The levelling margin is between boiler hanging level, and hanging backwards a little.



The boiler should **not lean forward** in the mounted position.

Lock the suspension bracket with the locking strip to prevent the boiler from falling off the bracket (See drawing).

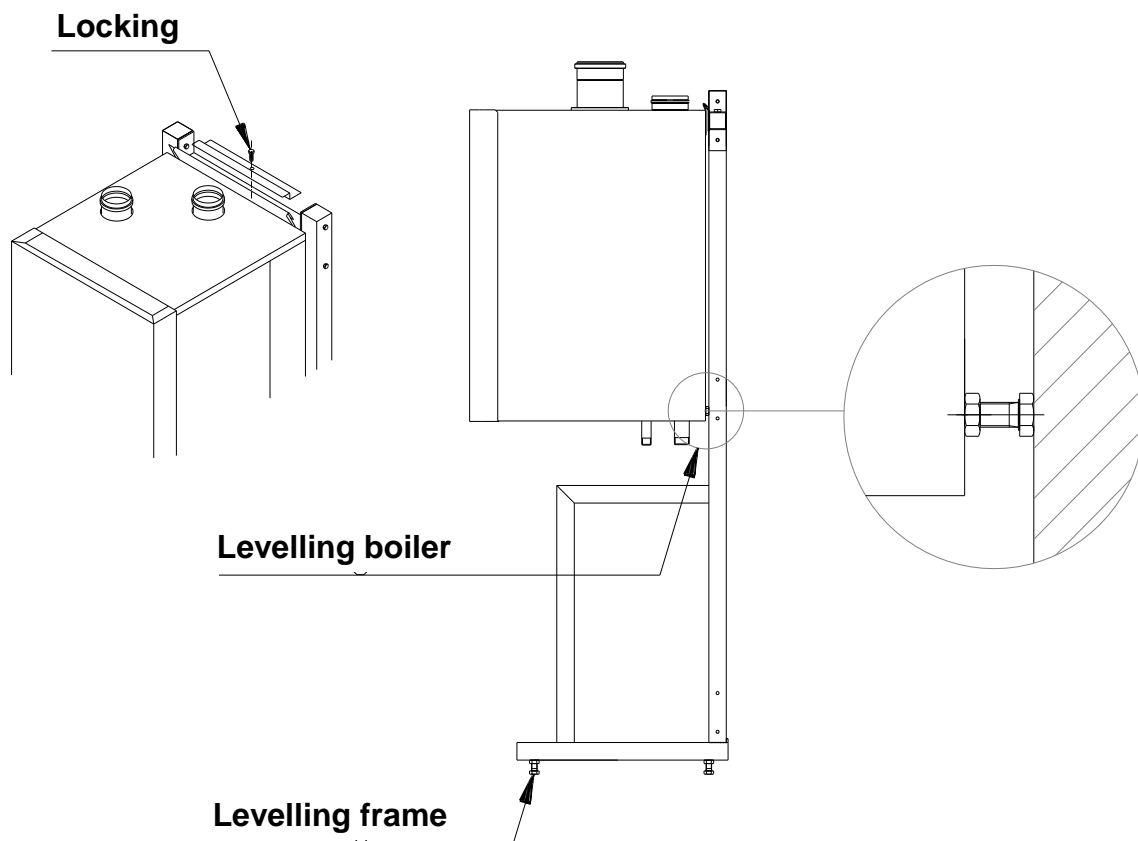

### 5.1 Mounting details.

## 6. Mounting the connecting sets

First, connect the connecting sets hand-tight to the boiler connections. In a cascade set-up, do NOT use the T-pieces delivered with the boilers.

The shortest connecting set should be connected to the gas connection on the boiler.

Make sure to connect the flow connecting set (middle length) to the boiler flow connection (left-side connection) and the return connecting set (longest) to the boiler return connection (right-side connection).

The open connection in the flow connecting set is meant for a pressure relief valve, and the one in the return connecting set is to be used for an 8litre expansion vessel as per BS6644.

A kit is available as an ancillary option.



**For the CPM SP116 boiler the return connecting set differs, due to the external pump.**

### Flow connecting set

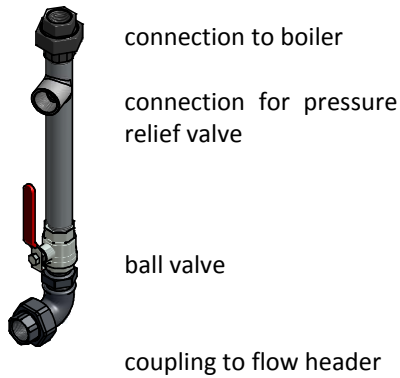

### Return connecting set

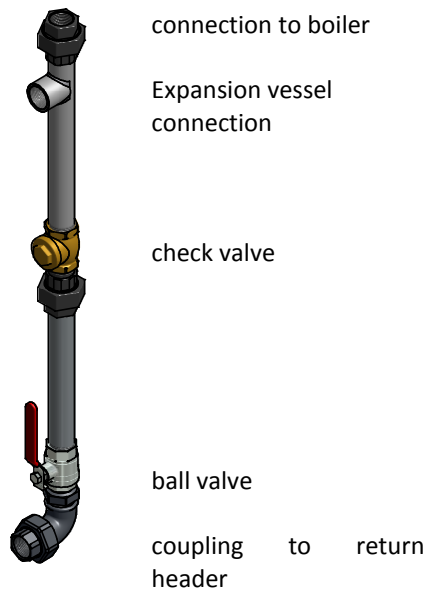

### Gas connecting set

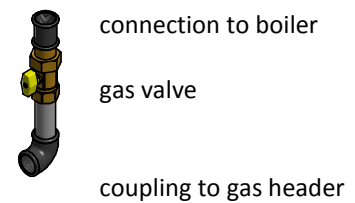

### CPM CPM SP boiler with external pump:

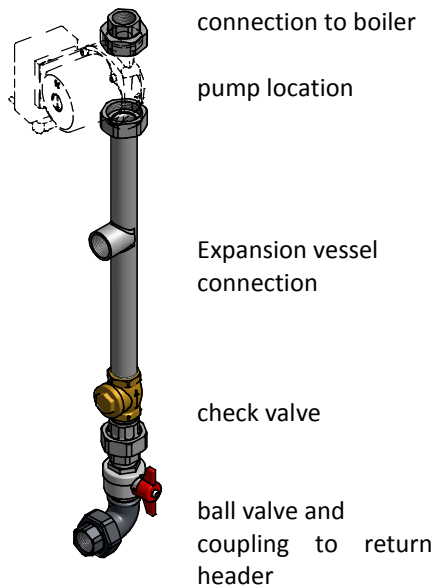

### 6.1 Connecting sets.

<b>Connecting pipework sets for boilers CPM58-CPM116 and CPM SP</b>			
<b>Description</b>	<b>2</b>	<b>3</b>	<b>4</b>
	<b>boilers</b>	<b>boilers</b>	<b>boilers</b>
	<b>Quantity Required</b>	<b>Quantity Required</b>	<b>Quantity Required</b>
Connecting set gas ¾"	2	3	4
Flow connecting set 1"	2	3	4
Return connecting set <b>CPM</b> 1"	2	3	4
Return connecting set <b>CPM SP</b> 1"	2	3	4
Connection size relief valve and bleed valve: both Rp 1"			

<b>Connecting sets for boilers CPM144-CPM175</b>			
<b>Description</b>	<b>2</b>	<b>3</b>	<b>4</b>
	<b>boilers</b>	<b>boilers</b>	<b>boilers</b>
	<b>Quantity Required</b>	<b>Quantity Required</b>	<b>Quantity Required</b>
Connecting set gas 1"	2	3	4
Flow connecting set 1 1/4"	2	3	4
Return connecting set 1 1/4"	2	3	4
Connection size relief valve and bleed valve: both Rp 1"			

## 7. Mounting the hydraulic group

Connect the gas header to the gas connecting sets.  
Connect the flow header to the flow connecting sets.  
Connect the return header to the return connecting sets.  
Mount all headers with the clamps to the frame.

All lines/piping must be mounted free of tension. The weight of all the components must be supported separately from the boiler so there is no force on the connections. This might influence the mounting position of the boiler.

When all parts are mounted in the right place, and are free of tension, fasten all couplings and fasten the clamps.

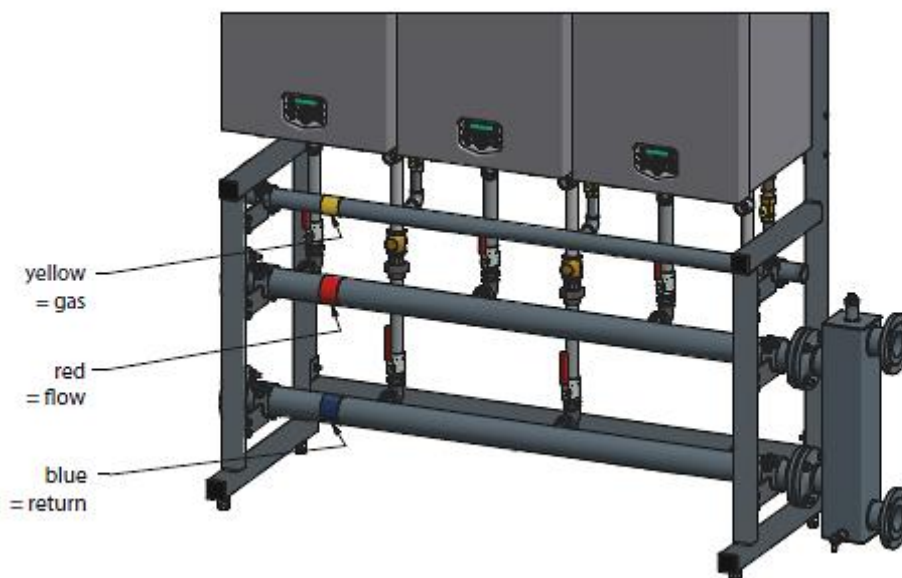

## 7.1 Hydraulic group for 2 boilers CPM 58–116 and/or CPM SP

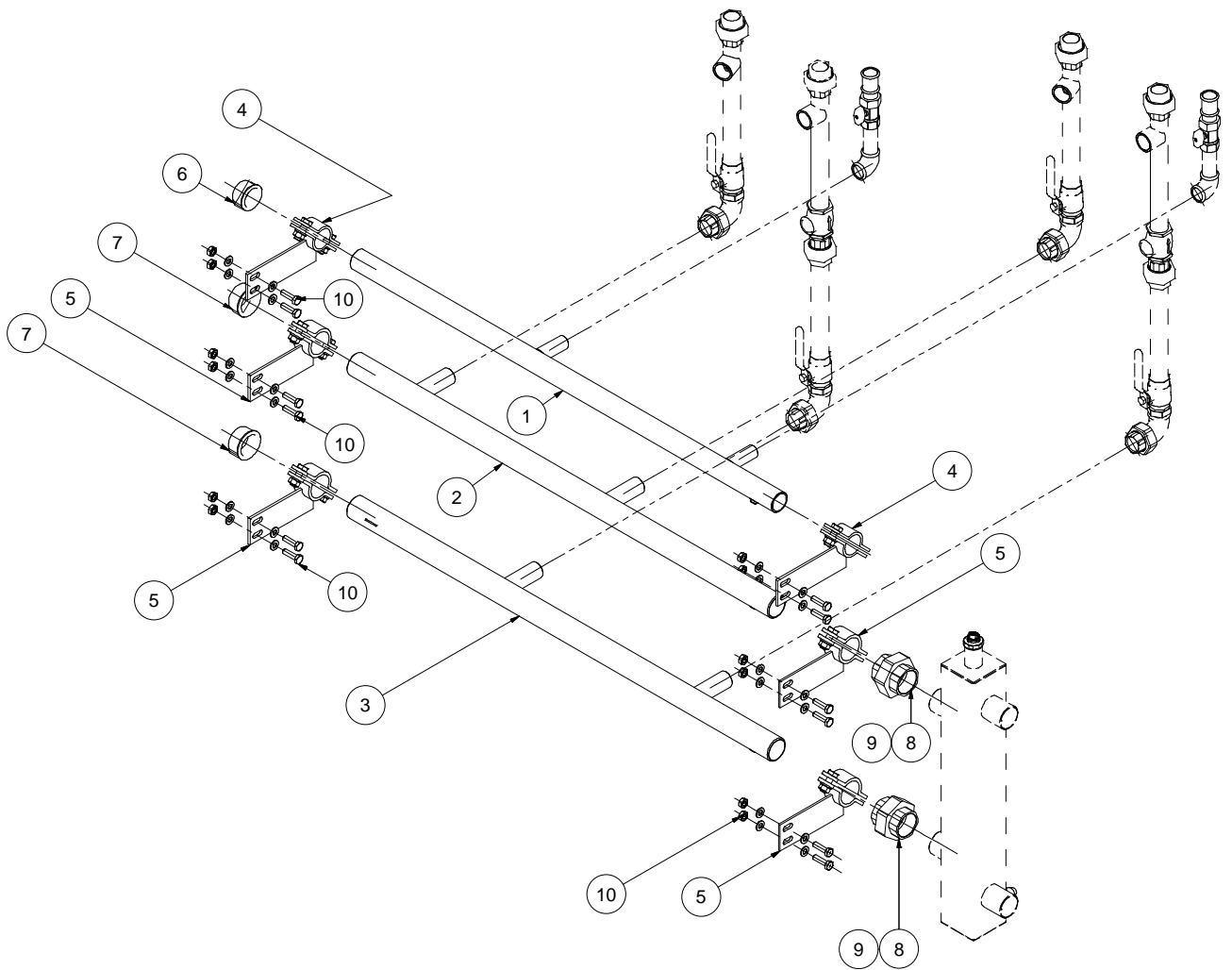

Connecting sets in the picture are CPM versions.

Item Number	Description	Hydraulic group for 2 Boilers
		Quantity
1	gas header	1
2	flow header	1
3	return header	1
4	clamp gas header	2
5	clamp flow/return header	4
6	seal cap gas header	1
7	seal cap flow/return header	2
8	coupling (2-parts)	2
9	gasket for coupling	2
10	bolt + nut + washer	24

## 7.2 Hydraulic groups for 3 and 4 boilers CPM 58–116 and/or CPM SP

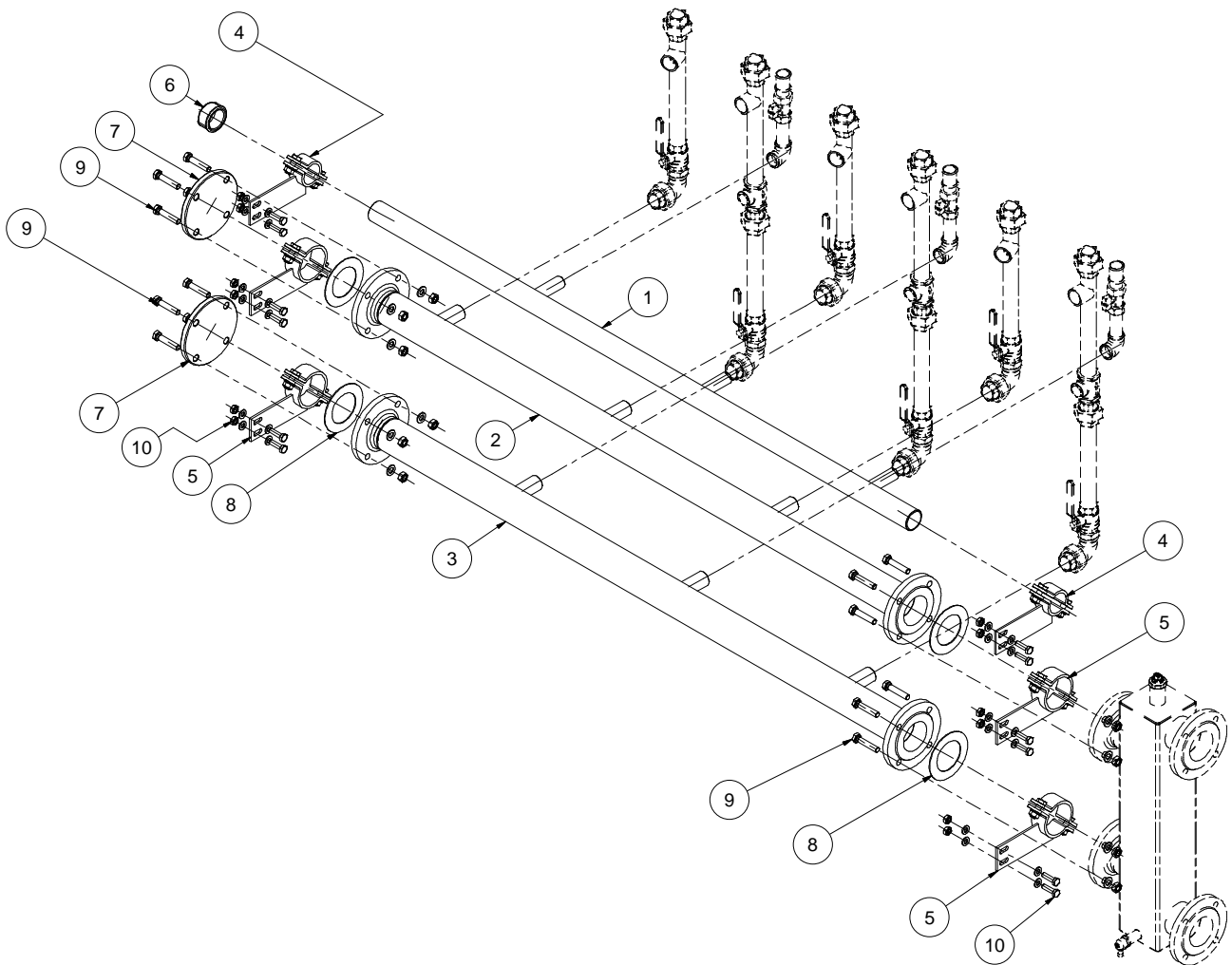

Connecting sets in the picture are CPM versions.

Item Number	Description	Hydraulic group for	
		3 Boilers	4 Boilers
		Quantity	Quantity
1	gas header	1	1
2	flow header	1	1
3	return header	1	1
4	clamp gas header	2	3
5	clamp flow/return header	4	6
6	seal cap gas header	1	1
7	seal cap flow/return header	2	2
8	coupling (2-parts)	4	4
9	gasket for coupling	16	16
10	bolt + nut + washer	24	36

### 7.3 Hydraulic groups for 2 and 3 boilers CPM 144–175

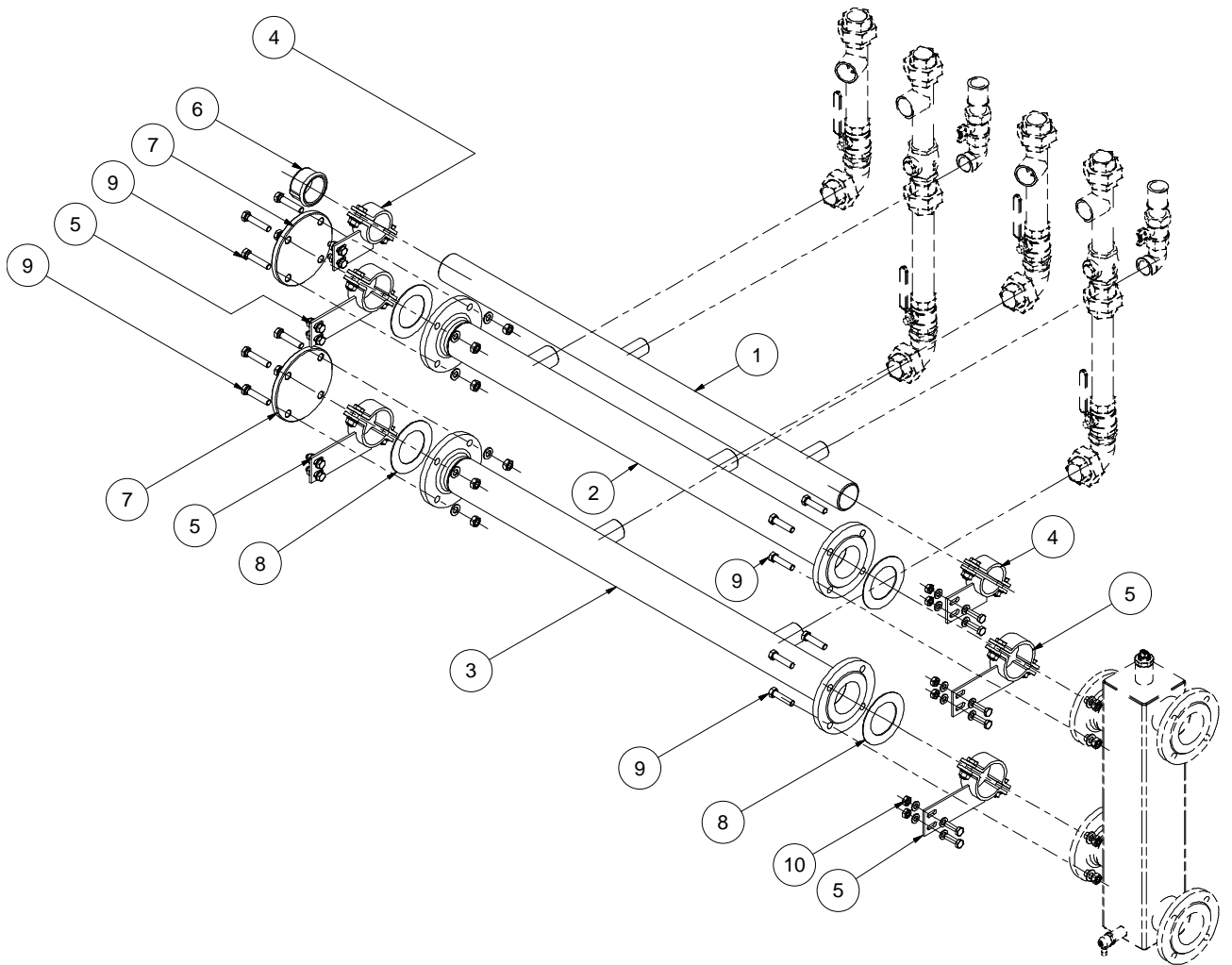

Item Number	Description	Hydraulic group for	
		2 Boilers	3 Boilers
		Quantity	Quantity
1	gas header	1	1
2	flow header	1	1
3	return header	1	1
4	clamp gas header	2	3
5	clamp flow/return header	4	6
6	seal cap gas header	1	1
7	seal cap flow/return header	2	2
8	coupling (2-parts)	4	4
9	gasket for coupling	16	16
10	bolt + nut + washer	24	36

## 7.4 Hydraulic group for 4 boilers CPM 144–175

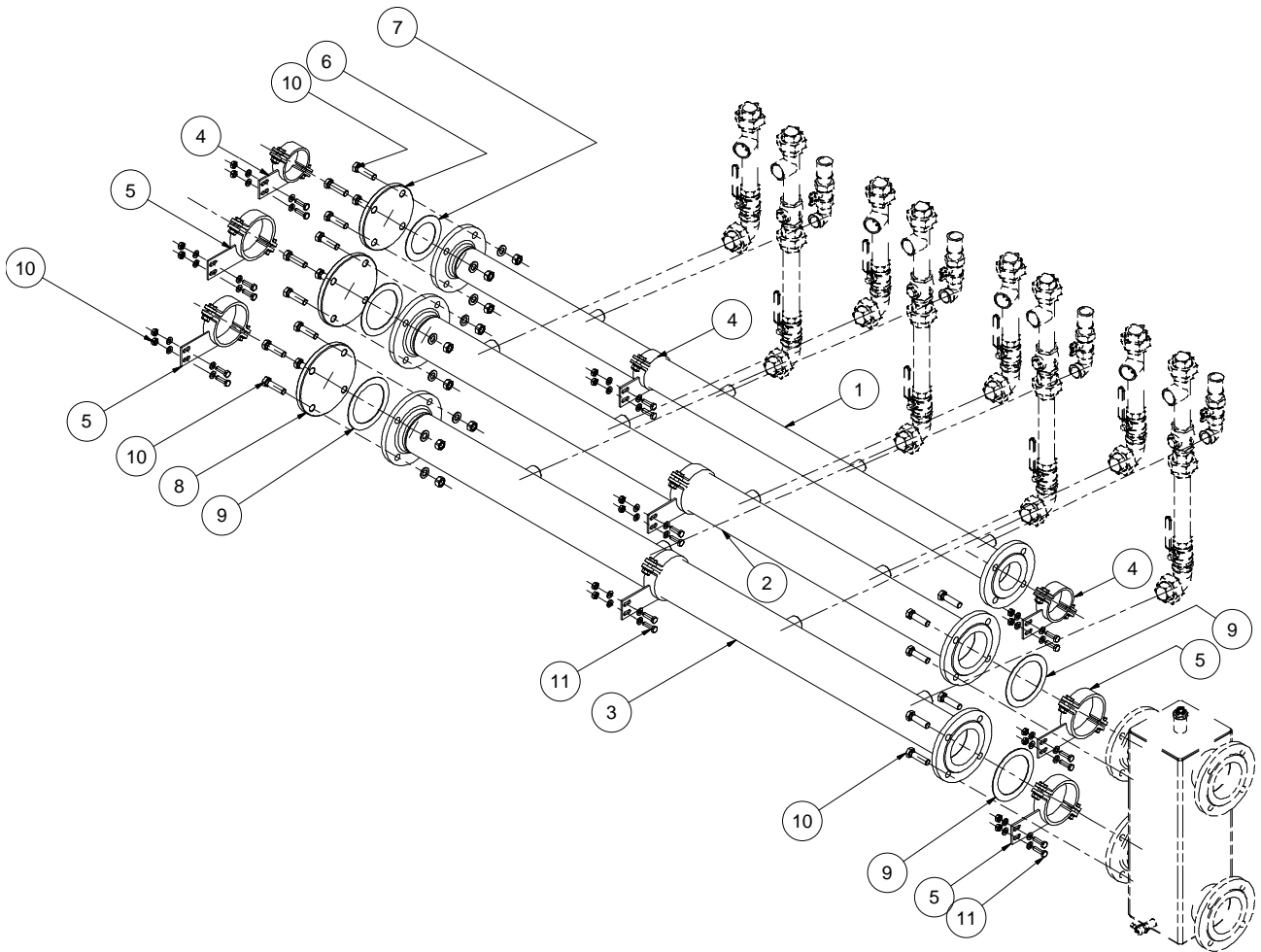

Item Number	Description	Hydraulic group for
		4 Boilers Quantity
1	gas header	1
2	flow header	1
3	return header	1
4	clamp gas header	2
5	clamp flow/return header	4
6	seal cap gas header	1
7	seal cap flow/return header	2
8	coupling (2-parts)	4
9	gasket for coupling	16
10	bolt + nut + washer	24



## 8. Low velocity headers

The low velocity header can be mounted on the right-hand or the left-hand side of the flow and return headers, whatever is the best place to connect the headers to the heating installation. The supplied caps or flanges must block the opposite end of the flow and return headers.

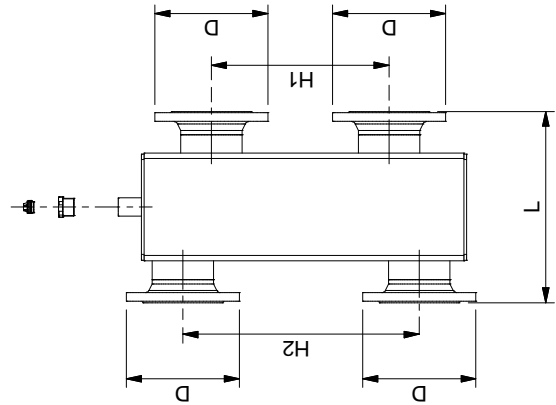
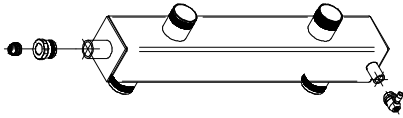
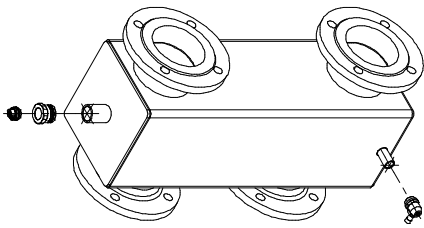

Fig. 8.2

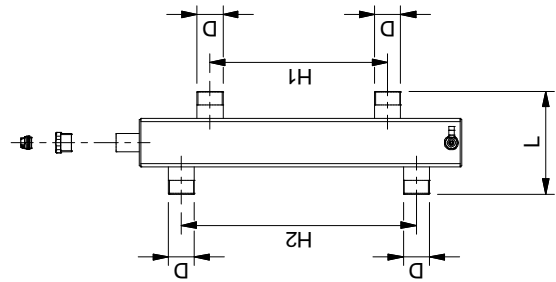

Fig. 8.1

Figure 2. Low velocity headers.

<b>Low velocity headers for boilers 58 – 116</b>				
<b>Low velocity group</b>	<b>2 boilers: E00.000.164</b>	<b>3 boilers: E00.000.165</b>	<b>4 boilers: E00.000.166</b>	<b>4 boilers: E00.000.167</b>
Drawing	Fig. 8.1	Fig. 8.2	Fig. 8.2	Fig. 8.2
Venting valve ½" <sup>1</sup>	E04.015.066	E04.015.066	E04.015.066	E04.015.066
Drain valve ½"	E04.008.025	E04.008.025	E04.008.025	E04.008.025
D	R 1½"	DN 65 PN6 (2½")	DN 80 PN6 (3")	DN 80 PN6 (3")
H1 (boiler-side)	330	330	330	330
H2 (installation-side)	436	487	440	440
L	190	265	290	290
<b>Low velocity headers for boilers 117 – 167</b>				
<b>Low velocity group</b>	<b>2 boilers E00.000.165</b>	<b>3 boilers E00.000.166</b>	<b>4 boilers E00.000.167</b>	<b>4 boilers E00.000.167</b>
Drawing	Fig. 8.2	Fig. 8.2	Fig. 8.2	Fig. 8.2
Venting valve ½" <sup>1</sup>	E04.015.066	E04.015.066	E04.015.066	E04.015.066
Drain valve ½"	E04.008.025	E04.008.025	E04.008.025	E04.008.025
D	DN 65 PN6 (2½")	DN 80 PN6 (3")	DN 96 PN6 (4")	DN 96 PN6 (4")
H1 (boiler side)	330	330	330	330
H2 (installation side)	487	440	439	439
L	265	290	355	355

<sup>1</sup> : We standard supply a manual venting valve that can be mounted on top of the low loss header to manually bleed the air from the low loss header. Instead of the ½" manual bleed valve, an automatic air vent can be installed, up to 1" max.

## 9. Plate separators

For systems where the water quality cannot be guaranteed it may be better to install a plate separator instead of a low velocity header. This will isolate the boilers hydraulically from the dirty system. A suitable plate is available as an option from Lochinvar; these are sized based on the number of boilers required.



See section 6.15 in CPM/CPM-SP Installation Manual for important information regarding the use of a plate separator.

## 10. Flue gas and air supply

### 10.1 Individual or common flue systems

Lochinvar Limited CPM/CPM SP cascade-sets can be equipped with individual or common flue systems. Using separate venting material is always preferred above common venting. Only when separate venting cannot be used, should a common vent system be used.

When chosen for an individual flue system each boiler has its individual flue gas outlet and air supply lines to the outside of the building. This may be executed in *parallel* or *concentric* flue gas and air supply pipes. When chosen for a common flue system this must be executed in *parallel* flue gas and air supply pipes.

### 10.2 Individual flue systems

Individual flue systems can be chosen as mentioned in the CPM instruction manual.

The flue system should comply with the chapter “**Flue gas and air supply system**” of the CPM/CPM SP manual.

For each boiler, the combined resistance of the individual flue gas and air inlet pipe can be calculated and checked with the maximum for the gas-side resistance.

Resistance table and example calculations are given in the same aforementioned chapter of the CPM manual.

### 10.3 Common flue systems

Common flue systems must be designed according to:

EN 13384-2 “Chimney – Thermal and fluid dynamic calculation methods – Part 2: Chimneys serving more than one heating appliance.”

For common flue gas systems, the parameter P5DB has to be adjusted to prevent recirculation of flue gases.

Lochinvar can supply a common flue cascade system for up to 4no CPM58-116 boilers, see CPM ICM manual for details available at [www.lochinvar.ltd.uk](http://www.lochinvar.ltd.uk)

## 11. Installation

Follow the instruction given within the ICM manual for either the CPM or CPM SP, these are available from Lochinvar Limited at [www.lochinvar.ltd.uk](http://www.lochinvar.ltd.uk)

## 12. Cascade control

### 12.1 Output control

The total cascade set-up will act as one single big boiler, switching on- and off boilers, depending on the total load necessary to adjust and keep the flow temperature at the calculated value.

When the heat demand rises, more boilers are switched on, and when heat demand falls, one or more boilers will be switched off. The boiler that was switched on last, will be switched off first (see table below).

### 12.2 Boiler sequence

To distribute operating hours equally over all boilers, the working sequence of the boilers will change every two hours.

Hour	Switching ON sequence	Switching OFF sequence
X	Master – Slave 1 – Slave 2 – Slave 3 – Slave 4 – Slave 5 – Slave 6 – Slave 7	Slave 7 – Slave 6 – Slave 5 – Slave 4 – Slave 3 – Slave 2 – Slave 1 – Master
X+1	Slave 7 – Master – Slave 1 – Slave 2 – Slave 3 – Slave 4 – Slave 5 – Slave 6	Slave 6 – Slave 5 – Slave 4 – Slave 3 – Slave 2 – Slave 1 – Master – Slave 7
X+2	Slave 6 – Slave 7 – Master – Slave 1 – Slave 2 – Slave 3 – Slave 4 – Slave 5	Slave 5 – Slave 4 – Slave 3 – Slave 2 – Slave 1 – Master – Slave 7 – Slave 6
X+3	Slave 5 – Slave 6 – Slave 7 – Master – Slave 1 – Slave 2 – Slave 3 – Slave 4	Slave 4 – Slave 3 – Slave 2 – Slave 1 – Master – Slave 7 – Slave 6 – Slave 5
.....	.....	.....

**Table 1.** Boiler sequence example of an eight boiler cascade.

In this table a total of eight boilers (one master, seven slaves) is mentioned as an example, in practice the maximum number in a cascade, without extra (external) control, is twelve boilers.

## 13. Options

To complete your cascade set-up / heating installation you can choose for next options:

<b>Room Temperature Controllers</b>			
<b>1</b>	RC OpenTherm with ambient sensor	Modulating	S04.016.355
<b>2</b>	RC OpenTherm with remote ambient sensor	Modulating	S04.016.358
<b>3</b>	Clock thermostat	On / Off	E04.016.308
<b>4</b>	RCH E-bus with ambient sensor (for EBC)	Modulating	S04.016.357
<b>5</b>	RCH E-bus with remote ambient sensor (for EBC)	Modulating	S04.016.361
<b>Plate Separators</b>			
<b>6</b>	Plate separator for CPM SP232 Package		LOKG-250L
<b>7</b>	Plate separator for CPM SP348 Package		LOKG-400L
<b>8</b>	Plate separator for CPM SP464 Package		LOKG-450L
<b>Sensors</b>			
<b>9</b>	Outside air temperature sensor	12kOhm@25°C	E04.016.306
<b>10</b>	External flow temperature sensor low velocity header	10kOhm@25°C	E04.016.304
<b>11</b>	External ambient sensor for RC and RCH	5kOhm@25°C	E04.016.359
<b>12</b>	External flow temperature sensor heating circuit (zone)	5kOhm@25°C	E04.016.363
<b>Heating circuit controller</b>			
<b>13</b>	EBC 2-zone E-bus controller		E04.016.319
<b>14</b>	Wall-mounted case with terminal board for EBC		E04.000.103
<b>15</b>	IF OpenTherm / E-bus interface		E04.016.362
<b>Parameter programming</b>			
<b>16</b>	Interface cable and software to programme the boiler		S04.016.586

**Table 2.** Accessories and parts.

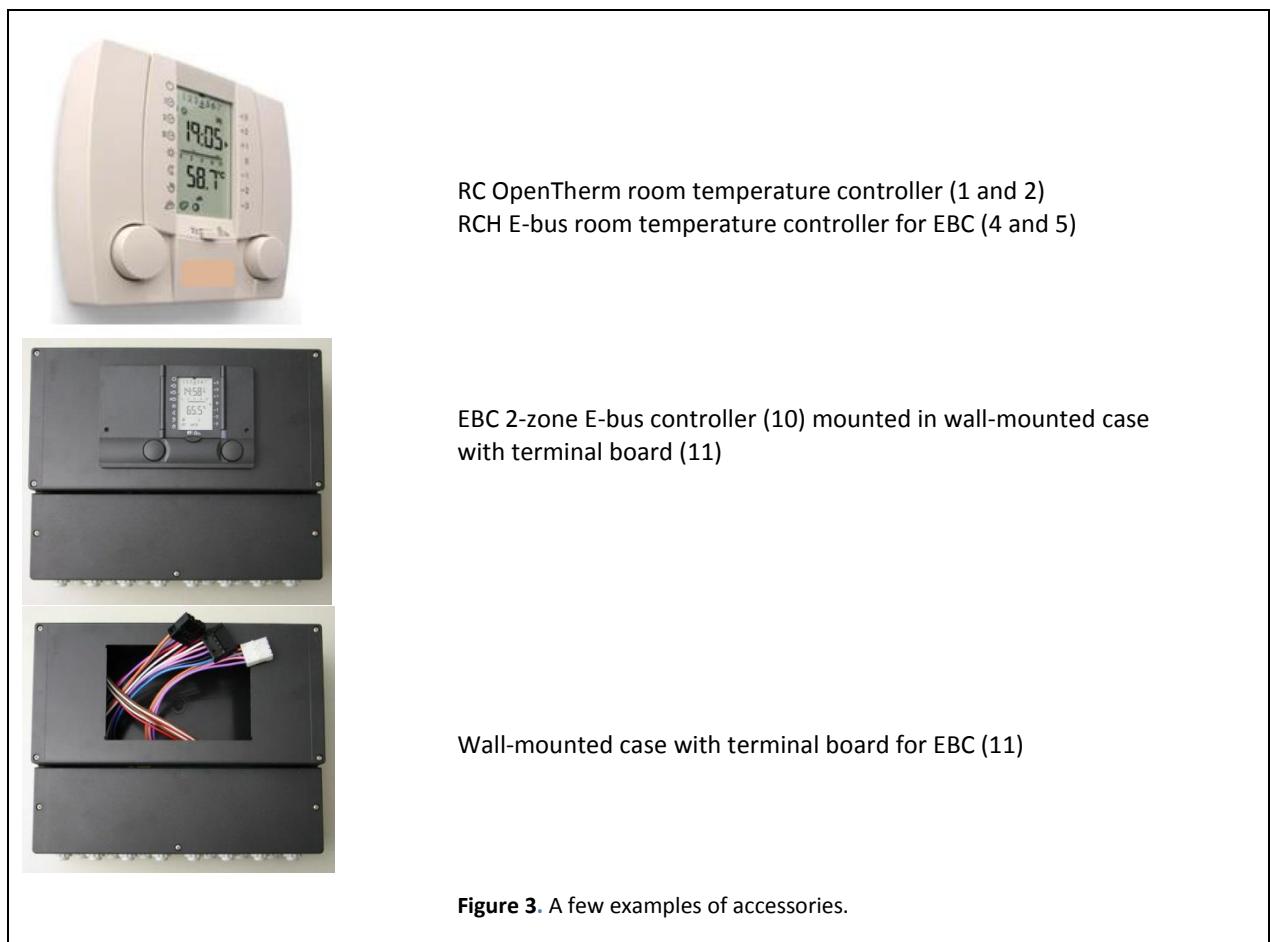

- notes -

- notes -



## IMPORTANT INFORMATION

These instructions must be read and understood before installing, commissioning, operating or maintaining the equipment.

