

LSTR Direct Storage Vessel

Installation, Commissioning,
User & Maintenance Instructions

Models:

LSTR 66 G E
LSTR 100 G E
LSTR 110 G E
LSTR 130 G E
LSTR 165 G E
LSTR 220 G E

LV313762 | March 2025





IMPORTANT INFORMATION

These instructions must be read and understood before installing, commissioning, operating or maintaining the equipment.

**Read this manual
carefully**

Warning

Read this manual carefully before starting with the installation of the storage vessel. Failure to read the manual and to follow the printed instructions may lead to personal injury and damage to the storage vessel.

Copyright © 2023

All rights reserved.

Nothing from this publication may be copied, reproduced and/or published by means of printing, photocopying or by whatsoever means, without the prior written approval of the supplier.

The supplier reserves the right to modify specifications stated in this manual.

Trademarks

Any brand names mentioned in this manual are registered trademarks of their respective owners.

Liability

The supplier accepts no liability for claims from third parties arising from unauthorised use, use other than that stated in this manual, and use other than in accordance with the General Conditions registered at the Chamber of Commerce.

Refer further to the General Conditions. These are available on request, free of charge.

Although considerable care has been taken to ensure a correct and suitably comprehensive description of all relevant components, the manual may nonetheless contain errors and inaccuracies. Should you detect any errors or inaccuracies in the manual, we would be grateful if you would inform us. This helps us to further improve our documentation.

More information

If you have any comments or queries concerning specific aspects related to the storage vessel, then please do not hesitate to contact the supplier.

In the event of problems with your water supply connections, please contact the supplier and/or installation engineer of your installation.

Regulations

If the Lochinvar LSTR is to be used in an unvented system installation, the system should follow the guidance given in BS6700, BS8558 and must comply with the Building Regulations 1992: Part G3, in England and Wales, P5 in Northern Ireland and P3 in Scotland and the Water Supply (Water Fittings) Regulations 1999, The Water Supply (Water Quality) Regulations (Northern Ireland) 2017 and the Public Water Supplies (Scotland) Amendment Regulations 2017.

A kit of parts is available from Lochinvar.

Table of contents

1	Technical specifications	5
1.1	Floor load	5
1.2	Working clearance	5
1.3	Packaging	5
1.4	Disposal	5
1.5	General specifications	5
1.6	Dimensions	6
2	Installation	7
2.1	Installation diagram	7
2.2	Water connections	7
3	Filling and Draining	9
3.1	Filling	9
3.2	Draining	10
4	Maintenance	11
4.1	Preparation for maintenance	11
4.2	Water-side maintenance	11
5	Warranty	13
5.1	General warranty	13
5.2	Tank warranty	13
5.3	Conditions for installation and use	13
5.4	Exclusions	14
5.5	Scope of warranty	14
5.6	Claims	14
5.7	Obligations of Lochinvar Ltd	14

1 Technical specifications

1.1 Floor load

Allow for the storage vessels weight and the maximum floor load; refer to the table (1.5 "General specifications").

1.2 Working clearance

For access to the storage vessel it is recommended that the following clearances are observed:

- around the anode connection: 100 cm.
- around the vessel: 50 cm.
- top of the vessel: 50 cm

Note

When installing the storage vessel, be aware that any leakage from the tank and/or connections can cause damage to the immediate environment or floors below the level of the boiler room. If this is the case, the storage vessel should be installed above a waste water drain or in a suitable metal leak tray.

The leak tray must have an appropriate waste water drain and must be at least 5 cm deep with a length and width at least 5 cm greater than the diameter of the storage vessel.

1.3 Packaging

The packaging prevents damage to the appliance during transport. The packaging material chosen is environmentally friendly, recyclable and relatively easy to dispose of in an environmentally aware way.



1.4 Disposal

Old end-of-life appliances contain materials that need to be recycled. When disposing of old devices that have reached the end of their service life, you should take account of local legislation relating to waste disposal.

You must therefore never dispose of your old appliance together with regular waste, but should and it into a municipal waste collection depot for electrical and electronic equipment. Ask your dealer/installation engineer for advice if necessary. The old appliance must be stored out of reach of children.



1.5 General specifications

Description	Unit	LSTR 66	LSTR 100	LSTR 110	LSTR 130	LSTR 165	LSTR 220
Storage Capacity	liters	312	405	499	678	763	1055
Empty Weight	kg	81	99	131	179	201	262
Max. Floor Load	kg	393	504	630	857	964	1317
Energy Efficiency Class (Energy Label)	-	C	C	C	-	-	-
Heat Loss	W	100	100	104	126	126	146
Max. Working Pressure Tank	kPa (bar)	1000 (10)	1000 (10)	1000 (10)	1000 (10)	1000 (10)	1000 (10)
Max. Water Temperature	°C	95	95	95	95	95	95
Anodes	-	1	1	1	1	1	1

1.6 Dimensions

		Unit	LSTR 66	LSTR 100	LSTR 110	LSTR 130	LSTR 165	LSTR 220
A	Total height	mm	1375	1710	2045	1840	2030	2000
D	Diameter (without insulation)	mm	600	600	600	750	750	900
	Diameter (with insulation)	mm	740	740	760	910	930	1100
J	Height connection	mm	705	1040	1375	1135	1330	1255
K	Height connection	mm	785	1115	1455	1220	1415	1340
L	Height connection	mm	860	1195	1530	1305	1500	1425
M	Height cold water inlet	mm	70	70	70	85	85	95
N	Height warm water outlet	mm	1320	1655	1995	1805	1970	2000
P	Height inspection opening	mm	410	410	410	500	500	535
S	Height immersion well/temp. sensor	mm	510	510	510	655	655	705
T	Height T&P	mm	1030	1365	1700	1475	1670	1595
W	Height connection	mm	270	270	270	320	320	365
X	Height connection	mm	350	350	350	405	420	460
Y	Height connection	mm	425	425	425	490	515	560
1	Connection	-	Rp ¼"	Rp ¼"	Rp ¼"	Rp ¼"	Rp ¼"	Rp ¼"
2	Connection	-	Rp ¾"	Rp ¾"	Rp ¾"	Rp ¾"	Rp ¾"	Rp ¾"
3	Connection	-	Rp 1¼"	Rp 1¼"	Rp 1¼"	Rp 1¼"	Rp 1¼"	Rp 1¼"
4	Connection	-	R 1½"	R 1½"	R 1½"	R 1½"	R 2"	R 2"
5	Connection	-	Rp 1½"	Rp 1½"	Rp 1½"	Rp 1½"	Rp 1½"	Rp 1½"
6	Connection	-	Rp 1½"	Rp 1½"	Rp 1½"	Rp 1½"	Rp 2½"	Rp 2½"
10	Diameter inspection opening	mm	115	115	115	180	180	180

Dimensioned Sketch

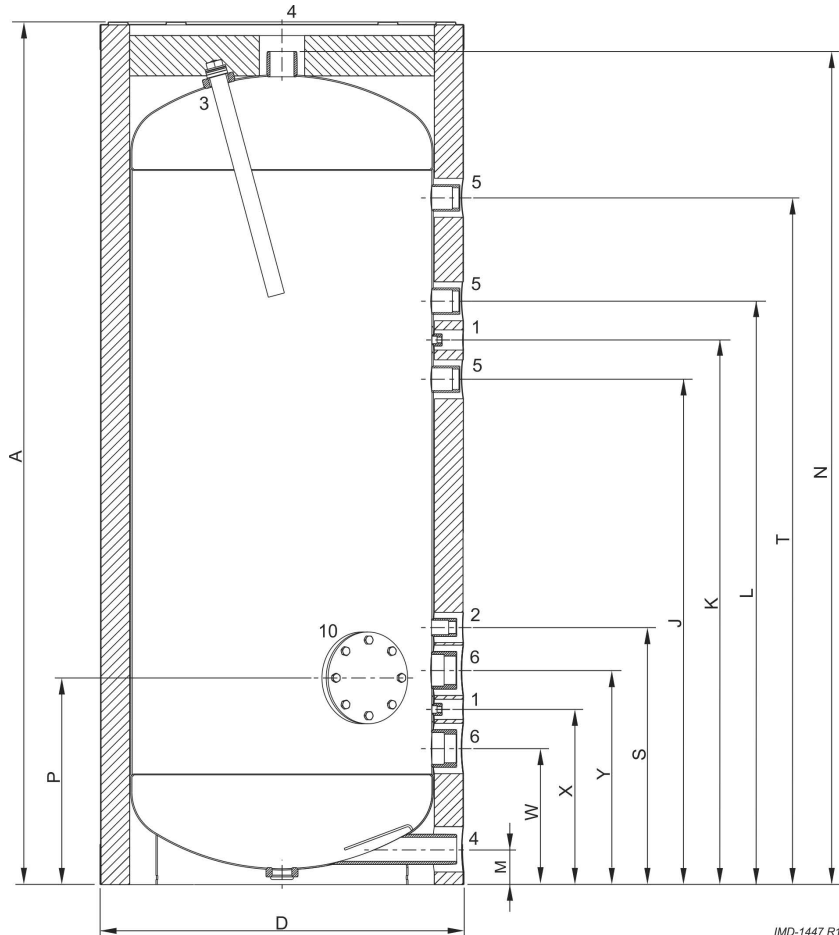

2 Installation

Note

These products can be installed as vented and unvented. This manual only discusses unvented installations. For information about vented installations please contact your supplier.

2.1 Installation diagram

The figures below show the installation diagrams. These diagrams are referred to in the sections describing the actual connection procedure.

Installation Diagrams

Legend

1. pressure relief valve (mandatory)
3. T&P-valve (mandatory)
4. stop valve (recommended)
5. non-return valve (mandatory)
6. circulation pump (optional)
9. drain valve
11. service stop valve
12. temperature gauge (optional)
14. draw-off points
15. expansion valve (mandatory)
16. expansion vessel (mandatory)

- A. cold water supply
B. hot water supply
C. circulation pipe

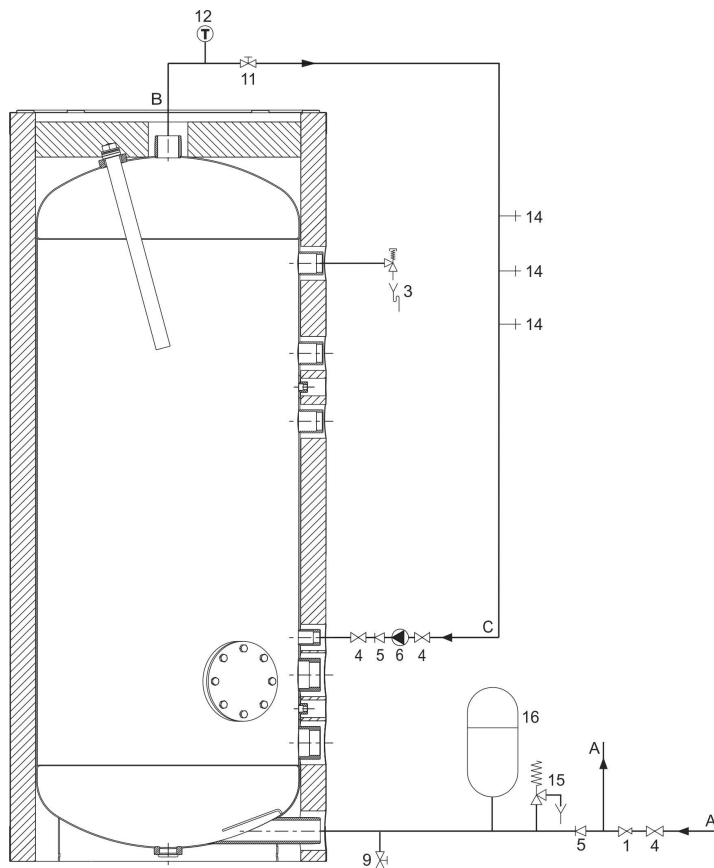

IMD-1448 R1

2.2 Water connections

Warning

The installation should be carried out by a competent person, in compliance with general and locally applicable regulations.

2.2.1 Cold water side

See (A) in the installation diagram (2.1 "Installation diagram").

1. Fit an approved stop valve (4) on the water supply side as required by the applicable regulations.
2. The maximum working pressure of the storage vessel is 10 bar. Because the pressure in the water pipe at times can exceed 10 bar, you must fit an approved pressure-reducing valve (1).

3. Fit a non-return valve (5) and an expansion vessel (16).
4. Fit an expansion valve (15) and connect the overflow side to an open waste water pipe.

2.2.2 Hot Water side

See (B) in the installation diagram ([2.1 "Installation diagram"](#)).

Note

Insulating long hot water pipes prevents unnecessary energy loss.

1. Optional: fit a temperature gauge (12) so you can check the temperature of the tap water.
2. Fit the T&P valve (3).
3. Fit a stop valve (11) in the hot water outlet pipe for servicing.

2.2.3 Circulation pipe

See (C) in the installation diagram ([2.1 "Installation diagram"](#)).

If an immediate flow of hot water is required at draw-off points, a circulation pump can be installed. This improves comfort, and reduces water wastage.

1. Fit a circulation pump (6) of the correct capacity for the length and resistance of the circulation system.
2. Fit a non-return valve (5) after the circulation pump to guarantee the direction of circulation.
3. Fit two stop valves for servicing (4).
4. Connect the circulation pipe according to the installation diagram ([2.1 "Installation diagram"](#)).

3 Filling and draining

Note

These products can be installed as vented and unvented. This manual only discusses unvented installations. For information about vented installations please contact your supplier.

Installation Diagram

Legend

1. pressure relief valve (mandatory)
3. T&P-valve (mandatory)
4. stop valve (recommended)
5. non-return valve (mandatory)
6. circulation pump (optional)
9. drain valve
11. service stop valve
12. temperature gauge (optional)
14. draw-off points
15. expansion valve (mandatory)
16. expansion vessel (mandatory)

- A. cold water supply
B. hot water supply
C. circulation pipe

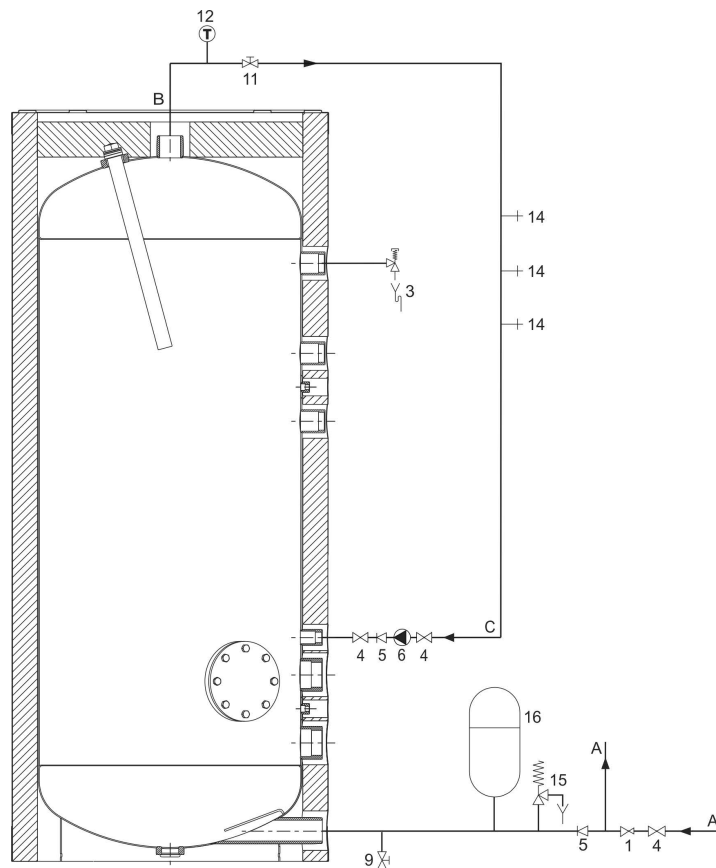

IMD-1448 R1

3.1 Filling

To fill the water heater, proceed as follows:

1. Open the stop valve (11) in the hot water pipe and, if present, the stop valves (4) for the circulation pump (6).
2. Close the drain valve (9).
3. Open the nearest hot water draw-off point (14).
4. Open the stop valve (4) on the cold water side (A) so that cold water flows into the water heater.
5. Completely fill the water heater. When a full water jet flows from the nearest draw-off point, the water heater is full.
6. Bleed the entire installation of air, for example by opening all draw-off points.
7. The water heater is now under water supply pressure. There should now be no water coming out of the inlet combination expansion valve or (if used) out of the T&P valve (3). If there is, the cause might be:
 - The water supply pressure is greater than the specified value (1.6 "General specifications"). Rectify this by fitting a pressure reducing valve (1).
 - The expansion valve in the protected cold supply set-up is defective or incorrectly fitted.

3.2 Draining

1. Close the stop valve (4) between the cold water head tank and the cold water inlet (A).
2. Open the drain valve (9).
3. Bleed the water heater (or installation) so that it drains completely.

4 Maintenance

Warning

Maintenance may only be carried out by a competent person.

At each service, the storage vessel undergoes maintenance on water side. The maintenance must be carried out in the following order.

1. Preparation for maintenance
2. Water-side maintenance
3. Finalising maintenance

Note

Before ordering spare parts, it is important to write down the installation type, storage vessel model and the full serial number of the storage vessel. These details can be found on the rating plate. Only by ordering with this information can you be sure receiving the correct spare parts.

4.1 Preparation for maintenance

The preparation for maintenance consists out of testing and checking if all components are still working properly by completing the following steps:

1. Test the operation of the overflow valve of the protected cold supply setup. The water should put out.
2. Check the drainage pipes from the discharge points of all valves and remove any scale deposits that may be present.
3. Drain the storage vessel.

4.2 Water-side maintenance

Water-side maintenance consists of descaling and cleaning the tank and checking the anode.

4.2.1 Descaling and cleaning the tank

Scale and lime build-up prevent effective conduction of the heat to the water. Periodic cleaning and descaling prevents build-up of these deposits. This increases the service life of the storage vessel, and also improves the heating process.

Take the rate of scale formation into account when deciding on the service interval. Scale formation depends on the local water composition, the water consumption and the water temperature setting. A water temperature setting of maximum 60°C is recommended for the prevention of excessive scale build-up.

To guarantee a good, watertight seal around the cleaning opening, replace the gasket, washers, bolts and, if necessary, the lid with new parts before reassembly. Spare parts are obtainable from the supplier/manufacturer.

To simplify descaling and cleaning of the tank, the storage vessel is equipped with a cleaning opening.

Work order:

1. Undo bolts from the cover.
2. Remove cover and the gasket.
3. Inspect the tank and remove the loose scale deposits and contamination.
4. If the scale cannot be removed by hand, descale the storage vessel with a descaling agent. Contact the supplier/manufacturer for advice on what descaling agent to use.
5. Close the cleaning opening. To avoid damage to the tank, tighten the bolts, that fasten the lid, with a torque no greater than 50 Nm. Use suitable tools for this.

4.2.2 Checking anode

Anode ensure the protection of the tank by sacrificing themselves. Insufficient anode material may lead to poor protection and, hence, leakage of the tank.

1. Loosen the anodes one by one.
2. Check the diameter of each anode in different places. The diameter must be at least 60% of the original diameter.
3. If the diameter is less than the minimum, the anode must be replaced. Please contact the supplier/manufacturer to order new anodes.
4. Mount the (new) anode.

5 Warranty

5.1 General warranty

If within 1 (one) year of the invoice date or commissioning date of a storage vessel supplied by Lochinvar Ltd, following verification, and at the sole discretion of Lochinvar Ltd, an assembly or part (with exclusion of the tank) proves to be defective or fails to function correctly due to manufacturing and/or material defects, then Lochinvar Ltd shall repair or replace this assembly or part.

5.2 Tank warranty

If within 3 (three) years of the invoice date or commissioning date of a storage vessel supplied by Lochinvar Ltd, following verification, and at the sole discretion of Lochinvar Ltd, the enamel-lined steel tank proves to be leaking due to rust or corrosion occurring on the water side, then Lochinvar Ltd shall offer to replace the defective storage vessel with an entirely new storage vessel of equivalent size and quality. The warranty period given on the replacement storage vessel shall be equal to the remaining warranty period of the original storage vessel that was supplied.

5.3 Conditions for installation and use

The warranty set out in articles 1 and 2 will apply solely under the following conditions:

- a. The storage vessel is installed under strict adherence to Lochinvar Ltd installation instructions for the specific model, and must be in accordance with the relevant requirements of the Gas Safety Regulations, Building Regulations, I.E.E. Regulations and the byelaws of the local water undertaking. The installation should also be in accordance with any relevant requirements of the local gas distributor and local authority.
- b. The storage vessel remains installed at the original site of installation.
- c. The storage vessel is used exclusively with drinking water, which at all times can freely circulate (a separately installed heat exchanger is mandatory for heating saline water or corrosive water).
- d. The tank is safeguarded against harmful scaling and lime build-up by means of periodic maintenance.
- e. The water temperatures in the storage vessel do not exceed the maximum setting of the thermostats, which form a part of the storage vessel.
- f. The water pressure and/or heat load do not exceed the maximum values stated on the storage vessel rating plate.
- g. The storage vessel is installed in a non-corrosive atmosphere or environment.
- h. The storage vessel is connected to a protected cold supply arrangement, which is: approved by the relevant authority; with sufficient capacity for this purpose; supplying a pressure no greater than the working pressure stated on the storage vessel; and where applicable by a likewise approved temperature and pressure relief valve, fitted in accordance with installation instructions of Lochinvar Ltd applying to the specific model of storage vessel, and further in compliance with Building Regulations, local authority installation byelaws and the Water Supply (Water Fittings) Regulations 1999 .
- i. The storage vessel is at all times fitted with cathodic protection. If sacrificial anodes are used for this and these anodes have reduced in size by more than 40% at any point along their length or if they are severely pitted, new anodes should be fitted. Particular attention should be paid to the ends of each anode to ensure excessive localized depletion has not occurred. Where anodes are covered with particles they should be cleaned; for reference, when new, the anode has a diameter of 21 mm. When power anodes are used, it is important to ensure that they continue to work properly.

5.4 Exclusions

The warranty set out in articles 1 and 2 will not apply in the event of:

- a. damage to the storage vessel caused by an external factor;
- b. misuse, neglect (including frost damage), modification and incorrect and/or unauthorized use of the storage vessel;
- c. contaminants or other substances having been allowed to enter the tank;
- d. any attempts at repair to a defective storage vessel other than by an approved service engineer.

5.5 Scope of the warranty

The obligations of Lochinvar Ltd pursuant to the specified warranty are limited to free delivery from the warehouse of the replacement assemblies, parts or storage vessel, respectively. Labor, installation and any other costs associated with the replacement will not be accepted by Lochinvar Ltd.

5.6 Claims

A claim on grounds of the specified warranty must be submitted to the dealer from whom the storage vessel was purchased, or to another authorized dealer of Lochinvar Ltd. Inspection of the storage vessel as referred to in articles 1 and 2 shall take place in one of the laboratories of Lochinvar Ltd.

5.7 Obligations of Lochinvar Ltd

Lochinvar Ltd grants no other warranty or guarantee over its storage vessels nor the (assemblies or parts of) storage vessels supplied for replacement, other than the warranty expressly set out in these conditions.

Under the terms of the supplied warranty, Lochinvar Ltd is not liable for damage to persons or property caused by (assemblies or parts, or the glass-lined steel tank of) a (replacement) storage vessel that it has supplied.



8 Lombard Way, The MXL Centre, Banbury, Oxon, OX16 4TJ
Tel: +44(0) 1295 269 981, Fax:+44(0) 1295 271 640, Email: info@lochinvar.ltd.uk
www.lochinvar.ltd.uk

Lochinvar Ltd reserves the right to change specifications without prior notice