

# TTW-TTB Flue Guide



Models covered:

TTW410

TTW580

TTB410

TTB580

## DOCUMENT CONTROL

Article	Language	Version	Modified by
TTW-TTB flue guide	English	V1.0 November 2021	S Hunt

## Contents

Certified flue systems.....	3
CONVENTIONAL FLUE SYSTEMS.....	4
Flue Sizing/Calculations .....	5
Flue Resistance Example .....	6
TWIN-PIPE FLUE SYSTEMS.....	7
Flue Sizing/Calculations .....	8
Flue Resistance Example .....	9
Order form and notes .....	10

Lochinvar Water Heaters are certified for use on the following flue categories:

Installation type	Category	Description
<b>B23</b>	Open flue	An appliance intended to be connected to a flue that evacuates the products of combustion to the outside of the room containing the appliance. The combustion air is drawn directly from the room.
<b>C13</b>	Closed Flue	An appliance connected to either a concentric or twin-pipe flue system with a Horizontal flue terminal. Both the air inlet and flue exhaust must be in the same pressure zone.
<b>C33</b>	Closed Flue	An appliance connected to either a concentric or twin-pipe flue system with a Vertical flue terminal. Both the air inlet and flue exhaust must be in the same pressure zone.
<b>C43</b>	Closed Flue	An appliance connected to a common air inlet and flue exhaust system, which is designed for more than one appliance. This common system has a single air inlet and flue exhaust and is part of the building not the appliance.
<b>C53</b>	Closed Flue	An appliance connected to a twin-pipe flue system with a Horizontal or Vertical flue terminal. Both air inlet and flue exhaust may be in different pressure zones.
<b>C63</b>	Closed Flue	An appliance intended to be connected to a separately approved and marketed system for the supply of combustion air and discharge of combustion products (i.e. other than that supplied by the water heater manufacturer).

All installations should comply with the requirements of:

1. The Clean Air Act for any termination or group of terminations with a total net heat input exceeding 333kW. Approval must be sought from the Local Authority prior to the commencement of the installation.
2. Horizontal flue terminations are not permitted for any termination or group of terminations with a total net heat input exceeding 333kW net heat input.

## CONVENTIONAL FLUE SYSTEMS

### CONVENTIONAL FLUE ASSEMBLY All Models

#### COMPONENTS REQUIRED TO START INSTALLATION

Item No.	Description	
LV310683	VERTICAL TERMINAL Ø200mm PP	1
LE04018124	ECCENTRIC INCREASER Ø180MM - Ø200MM FOR EXHAUST	1
LM900205A	AIR INLET SCREEN (160MM)	1

#### Additional Flue Ancillary Items

Item No.	Description
LV310696	EXTENSION Ø200MM (500MM) PP
LV310697	EXTENSION Ø200mm(1000mm) PP
LV310698	EXTENSION Ø200mm (2000mm) PP
LV310668	BEND 90° Ø200mm PP (A=227mm B=195mm)
LV310667	BEND 45° Ø200mm PP (111mm B=131mm)
LV310677	T PIECE WITH CONDENSATE COLLECTOR Ø200mm PP
M87198	WALL CLAMP Ø200mm

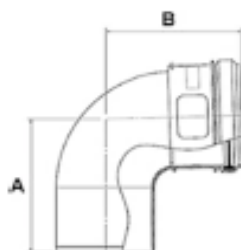
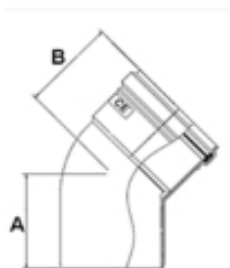
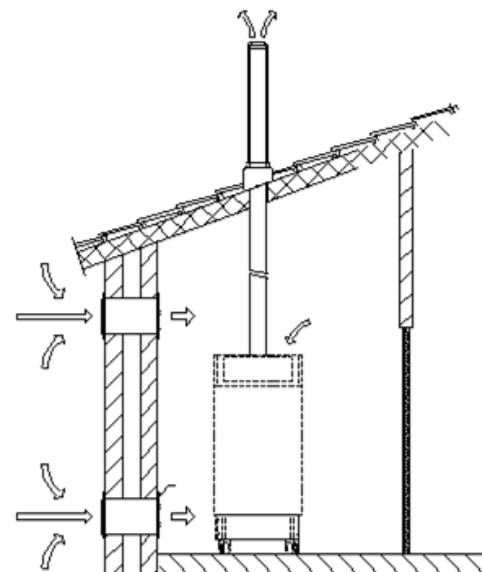

Flue Piece	mm	Resistance (Pa)	
		TTW/B 410	TTW/B580
1m Length	200	1.8	3.0
T-Piece Vertical Water Heater Outlet	200	16.7	29.7
90° Bend	200	6.5	11.6
45° Bend	200	3.7	6.6
Terminal	200	27.8	49.6
Air Inlet	200	18.2	32.4

Use the below table below to calculate the total flue system resistance

Item	Quantity	Resistance	Total
1m Length			
T-Piece			
90° Bend			
45° Bend			
Terminal			
Total Resistance (Pa)			



**Total calculated system resistance must be less than 200pa**



**To be used for Lochinvar supplied M&G flue system components resistance only**

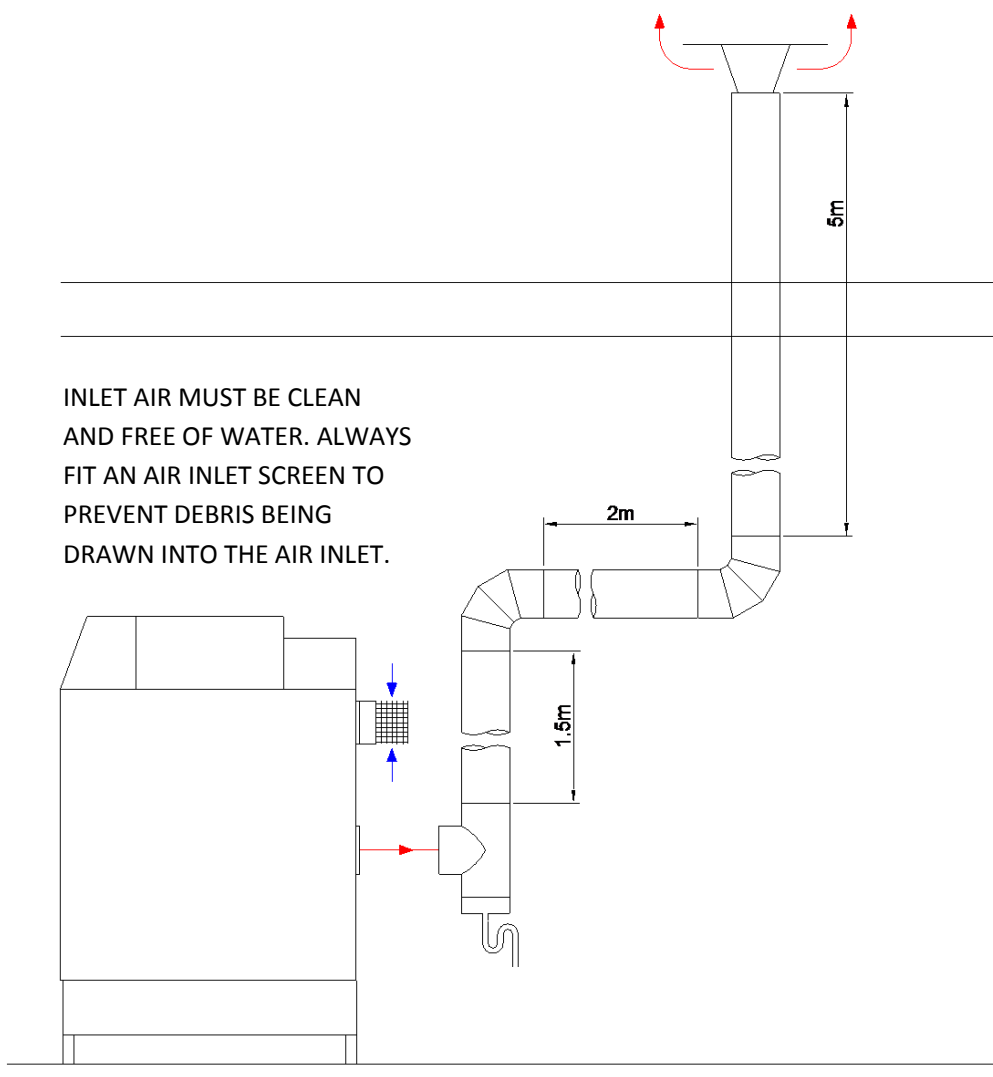

Unit Type		TTB410			
Flue Gas	Diameter: 200mm		Number	Pa	Pa Total
	1m Length	Total	8.5	1.8	15.3
	T-Piece	Outlet	1	16.7	16.7
	Bend	90°	2	6.5	13
	Terminal		1	27.8	27.8
	Total Resistance Flue Gas Outlet: 72.8				
Air Supply	Diameter: 180mm		Number	Pa	Pa Total
	Air Inlet	Total	1	18.2	18.2
	Total Resistance Flue Gas Outlet: 18.2				
Total Resistance Flue Gas Outlet and Air Supply 91 Pa					



The total resistance is less than 200 Pa, so this is acceptable

**TWIN-PIPE FLUE ASSEMBLY**

All Models

Components Required To Start Installation

**COMPONENTS INCLUDED**

Item No.	Description	
LV310683	VERTICAL TERMINAL Ø200mm PP	1
LE04018095	INCREASER Ø180MM TO Ø200MM FOR AIR INLET ONLY	1
LE04018124	ECCENTRIC INCREASER Ø180MM - Ø200MM FOR EXHAUST	1
LV310683	VERTICAL TERMINAL Ø200mm PP	1

**Additional Flue Ancillary Items**

Item No.	Description
LV310696	EXTENSION Ø200MM (500MM) PP
LV310697	EXTENSION Ø200mm(1000mm) PP
LV310698	EXTENSION Ø200mm (2000mm) PP
LV310668	BEND 90° Ø200mm PP (A=227mm B=195mm)
M70412	BEND 45° Ø200mm PP (A=111mm B=131mm)
LV310677	T PIECE WITH CONDENSATE COLLECTOR Ø200mm PP
M87198	WALL CLAMP Ø200mm

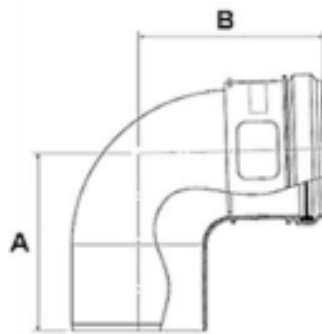
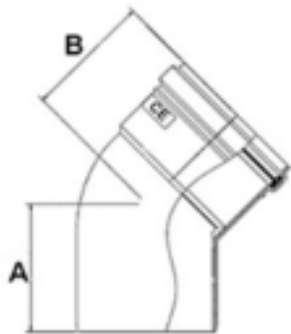
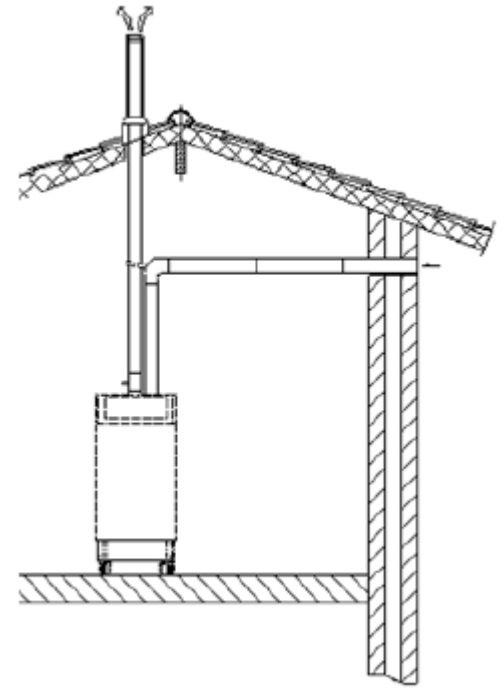



Flue Gas	mm	Resistance (Pa)	
		TTW/B 410	TTW/B580
1m Length	200	1.8	3.0
T-Piece Vertical Water Heater Outlet	200	16.7	29.7
90° Bend	200	6.5	11.6
45° Bend	200	3.7	6.6
Terminal	200	27.8	49.6

Air Supply Pipe	mm	Resistance (Pa)	
		TTW/B 410	TTW/B580
1m Length	200	1.3	2.1
T-Piece Vertical Water Heater Outlet	200	17.5	31.1
90° Bend	200	4.9	8.7
45° Bend	200	2.8	5.0
Air Inlet	200	18.2	32.4

Use the below table below to calculate the total flue system resistance

Item	Quantity	Resistance	Total
1m Length			
T-Piece			
90° Bend			
45° Bend			
Terminal			
Total Resistance (Pa)			



**Total calculated system resistance must be less than 200pa**



**To be used for Lochinvar supplied M&G flue system components resistance only**

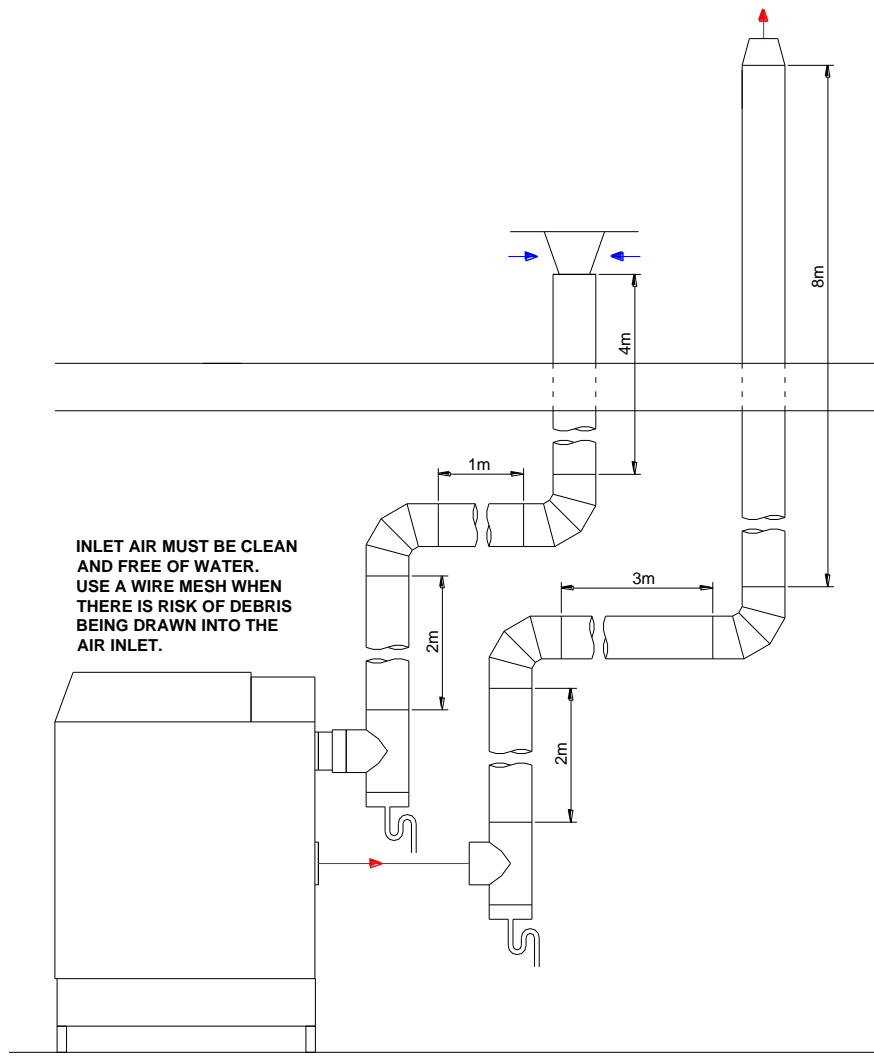

Unit Type		TTB410			
Flue Gas	Diameter: 200mm		Number	Pa	Pa Total
	1m Length	Total	13	1.8	23.4
	T-Piece	Outlet	1	16.7	16.7
	Bend	90°	2	6.5	13
	Terminal		1	27.8	27.8
Total Resistance Flue Gas Outlet: 80.9					
Air Supply	Diameter: 200mm		Number	Pa	Pa Total
	1m Length	Total	7	1.3	9.1
	T-Piece	Outlet	1	17.5	17.5
	Bend	90°	2	4.9	9.8
	Air Inlet	Total	1	18.2	18.2
Total Resistance Flue Gas Outlet: 54.6					
Total Resistance Flue Gas Outlet and Air Supply 135.5 Pa					



The total resistance is less than 200 Pa, so this is acceptable

Notes-Items to Order		
Item No	No Required	Notes

Contact Lochinvar customer service to order additional flue items on 01295 269981

