

# Descaling Descaling kit for water heaters and storage vessels

User Instructions

LV311272 | June 2022





## **IMPORTANT INFORMATION**

These instructions must be read and understood before installing, commissioning, operating or maintaining the equipment.

---

**Read this manual  
carefully**

---

**Warning**

Read this manual carefully before starting the descaling process. Failure to read the manual and to follow the printed instructions may lead to personal injury and damage to the water heater.

---

**Copyright © 2021**

All rights reserved.

Nothing from this publication may be copied, reproduced and/or published by means of printing, photocopying or by whatsoever means, without the prior written approval of the supplier.

The supplier reserves the right to modify specifications stated in this manual.

**Trademarks**

Any brand names mentioned in this manual are registered trademarks of their respective owners.

**Liability**

The supplier accepts no liability for claims from third parties arising from unauthorised use, use other than that stated in this manual, and use other than in accordance with the General Conditions registered at the Chamber of Commerce.

Refer further to the General Conditions. These are available on request, free of charge.

Although considerable care has been taken to ensure a correct and suitably comprehensive description of all relevant components, the manual may nonetheless contain errors and inaccuracies.

Should you detect any errors or inaccuracies in the manual, we would be grateful if you would inform us. This helps us to further improve our documentation.

**More information**

If you have any comments or queries concerning specific aspects related to the descaling set, then please do not hesitate to contact the supplier of the Descaling material.

In the event of problems with your water supply connections, please contact the supplier/installation engineer of your installation.

# Content

<b>1</b>	<b>Descaling .....</b>	<b>5</b>
1.1	Introduction .....	5
1.2	Descaling liquid .....	5
<b>2</b>	<b>Cleaning .....</b>	<b>6</b>
2.1	Introduction .....	6
2.2	Water heater or storage vessel with cleaning opening .....	6
2.3	Water heater or storage vessel without cleaning opening .....	8

# 1 Descaling

---

**Caution**

Maintenance may only be carried out by an approved service and maintenance engineer.

---

## 1.1 Introduction

This descaling liquid is a powerful colour-coded descale liquid. This liquid removes scaling and lime build-up. It prevents the loosened lime from re-attaching itself to the walls, which means the lime disappears during rinsing. Scale and lime build-up prevent effective conduction of the heat to the water. Periodic cleaning and descaling extends the service life of the water heater or storage vessel, improves the heating process and saves energy.

The service and maintenance engineer determines the required maintenance frequency. The frequency is subject to the degree of scale formation. Scale formation increases exponentially when the control temperature increases. For that reason, select the lowest possible control temperature. In doing so, note the heat requirements and the minimum return temperature in order to prevent legionella.

## 1.2 Descaling liquid

The descaling liquid is a concentrated product which, dependent on the amount of lime, can usually be used diluted with water in a 1:1 proportion. The amount of liquid to be used is subject to the capacity of the appliance, see Table below.

Storage capacity	Amount of bottles to be used
80 - 155 litres	6 (3 litres)
160 - 200 litres	8 (4 litres)
200 - 300 litres	12 (6 litres)
> 300 litres	20 (10 litres)

This liquid is a safe, biodegradable descaling liquid based on natural materials, including lactic acid and citric acid. It's allowed to discharge the diluted product.

---

**Caution**

The liquid is an acidic substance. Use the prescribed protection and always rinse the system with water.

---

These instructions consist of two parts:

1. instructions for water heater or storage vessel with cleaning opening;
2. instructions for water heater or storage vessel without cleaning opening.

# 2 Cleaning

---

## Caution

Maintenance may only be carried out by an approved service and maintenance engineer.

---

### 2.1 Introduction

This instruction can be used for water heaters and/or storage vessels. Some of the water heaters and/or storage vessels have been equipped with a cleaning opening. Descaling through this cleaning opening has specific steps way (2.2 "Appliance with cleaning opening"). Water heaters and/or storage vessels that don't have a cleaning opening must be descaled in a different way (2.3 "Appliance without cleaning opening"). Select the right instruction for the appliance.

### 2.2 Water heater or storage vessel with cleaning opening

Water heaters and/or storage vessels with a cleaning opening must be descaled in the following steps:

1. If applicable, switch off the appliance according to the instructions in the appliance (see Installation, Commissioning, User & Maintenance Instructions of water heater).
2. Drain the tank (see Installation, Commissioning, User & Maintenance Instructions of water heater and/or storage vessel).
3. Remove the cover plate from the cleaning opening on the outer jacket, see figure 1.

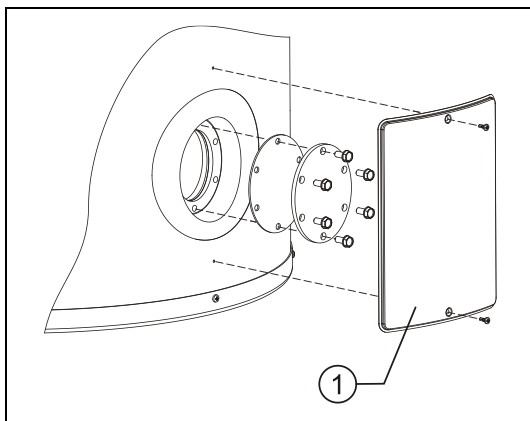

Figure 1. Example of a cleaning opening

4. Undo the bolts.
5. Remove the cover and the gasket.
6. Rinse the tank using tap water for removing any loose contamination.
7. Close the drain valve.
8. Remove any loose lime build-up manually.
9. If the lime build-up can't be removed by hand, then use the descaling liquid.

---

## Warning

Wear safety goggles and rubber gloves. The descaling liquid is irritating to the skin and may cause serious damage to the eyes.

---

10. Add the amount of litres of liquid, as described in table 1.
11. Dilute the descaling liquid with an equal amount of litres of water.

---

## Note

In case of serious lime build-up, use a double amount of descaling liquid undiluted. In case of little lime build-up, dilute the descaling liquid in a 1:2 proportion. The total amount of liquid should always tally with the number in Table 1.

---

12. Dependent on the degree of lime build-up, allow the mixture to sit in the tank for 1 to 2 hours. The descaling liquid is active up to a maximum of 2 hours. It becomes gradually less active.
13. Open the drain valve. Drain the mixture.
14. Calmly open the filling tap and thoroughly rinse the tank with tap water. The descaling liquid is an acid; therefore it is necessary to rinse with water.
15. Look in the cleaning opening to check whether all lime build-up has been removed. If not, repeat the descaling procedure.
16. Close the drain valve.
17. Close the cleaning opening. Tighten the bolts at a torque of no more than 50 Nm, in order to avoid damage to the tank. Use suitable tools for this. When tightening the bolts, stick to the sequence as shown in Figure 2.

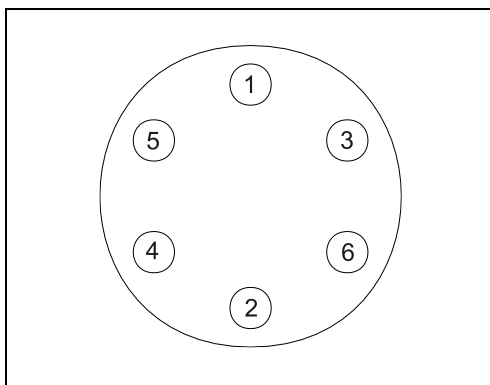

**Figure 2.** Bolt tightening sequence

---

**Note**

In order to guarantee watertight sealing of the cleaning opening, you will need to replace the gaskets and fasteners on a regular basis. For this purpose, a special set is available, depending on the water heater or storage vessel. Please contact Lochinvar Ltd..

---

**Note**

It is advised to check the anode(s) before filling the water heater and/or storage vessel.

---

**Important**

If sacrificial anodes are used and these anodes have reduced in size by more than 40% at any point along their length or if they are severely pitted, new anodes should be fitted. Particular attention should be paid to the ends of each anode to ensure excessive localized depletion has not occurred. Where anodes are covered with particles they should be cleaned; for reference, when new, the anode has a diameter of 21 mm. When power anodes are used, it is important to ensure that they continue to work properly.

---

18. Fill the water heater and/or storage vessel and start it again (see Installation, Commissioning, User & Maintenance Instructions of water heater and/or storage vessel).

---

**Note**

There will still be residues of the descaling agent in the used bottles. Dispose of these bottles correctly in compliance with the general and local regulations.

---

## 2.3 Water heater or storage vessel without cleaning opening

---

### Note

For descaling water heaters and/or storage vessels without a cleaning opening a special descaling set is needed. You can order this set with art.no. LV311275.

This special set consists out of the following parts:

- a funnel;
  - a hose;
  - hose clamps.
- 

Water heaters and/or storage vessels without a cleaning opening must be descaled in the following steps:

1. Switch off the water heater and/or storage vessel according to the instructions in the Installation, Commissioning, User & Maintenance Instructions of water heater and/or storage vessel.
  2. Drain the tank (see Installation, Commissioning, User & Maintenance Instructions of water heater and/or storage vessel). For this purpose, you can use the tail piece from the descaling set.
  3. Rinse the tank using tap water for removing any loose contamination.
  4. Remove the anode from the tank.
  5. Close the drain valve.
- 

### Warning

Wear safety goggles and rubber gloves. The descaling liquid is irritating to the skin and may cause serious damage to the eyes.

---

6. Place the funnel in the anode connection.
  7. Add the amount of litres of descaling liquid, as described in table 1.
  8. Dilute the descaling liquid with an equal amount of litres of water.
- 

### Note

In case of serious lime build-up, use a double amount of descaling liquid undiluted. In case of little lime build-up, dilute the descaling liquid in a 1:2 proportion. The total amount of liquid should always tally with the number in table 1.

---

9. Allow the mixture to sit in the tank for 2 hours.
  10. Open the drain valve. Drain the mixture.
  11. Check whether sufficient lime scale has been removed, by looking at the colour of the mixture. The descaling liquid is red. If the mixture has turned an orange / yellow colour, then there is still lime present. Repeat the descaling procedure.
  12. Calmly open the filling tap and thoroughly rinse the tank with tap water. The descaling liquid is an acid; therefore it is necessary to rinse with water.
  13. Fit the anode.
- 

### Important

If a sacrificial anode is used and this anode has reduced in size by more than 40% at any point along their length or if they are severely pitted, a new anode should be fitted. Particular attention should be paid to the ends of each anode to ensure excessive localized depletion has not occurred. Where anode is covered with particles they should be cleaned; for reference, when new, the anode has a diameter of 21 mm. When power anodes are used, it is important to ensure that they continue to work properly.

---

14. Close the drain valve.
15. Fill the water heater and/or storage vessel and start it again (see Installation, Commissioning, User & Maintenance Instructions of water heater and/or storage vessel)







8 Lombard Way, The MXL Centre, Banbury, Oxon, OX16 4TJ  
Tel: +44(0) 1295 269 981, Fax:+44(0) 1295 271 640, Email: info@lochinvar.ltd.uk  
www.lochinvar.ltd.uk

*Lochinvar Ltd reserves the right to change specifications without prior notice*