

Knight Low NO_x storage-type gas-fired water heaters



- Recovery rates from 140 to 290 litres/hour
- ErP compliant
- Up to 8 bar working pressure
- Low NO_x emissions <48mg/kWh
- Small footprint
- Natural gas or LPG

Knight Low NO_x storage-type water heaters

Knight Low NO_x water heaters are available in 4 models, with storage capacities ranging from 108 to 358 litres, and with hot water recovery rates ranging from 140 to 290 litres/hour. These recovery rates are based upon a temperature rise of 50°C.

This type of water has been established in the UK since 1976, when Lochinvar was one of the first companies to offer these products. The Knight Low NO_x range is based upon proven design which has been satisfying many hot water requirements for a wide range of commercial applications.



Knight Low NO_x
4 models available



Energy-related products directive (ErP)

This legislation covers a wide range of heating and hot water products, including gas-fired water heaters and was first introduced in September 2015. The overall aim of the legislation is to improve efficiency, reduce carbon emissions, and conserve energy. The most recent update increased minimum levels of operating efficiency, but for the first time applied maximum levels of NO_x emissions were introduced.

New burner design / Low NO_x emissions

The significant change to our established Knight range of water heaters, is in the new burner design, which helps these products provide Low NO_x emissions, ranging from 22mg/kWh to 48mg/kWh depending upon model. The popular LGL75 size providing the best result at 22mg/kWh, and therefore qualifies for the maximum 2 credits on BREAAAM projects. All models in the range are well within the maximum 56mg/kWh stipulated by the most recent ErP legislation.

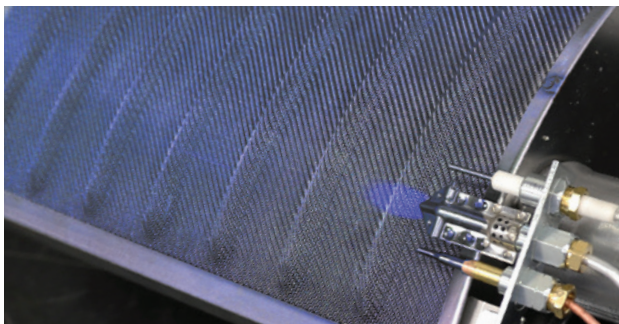

Low NO_x Burner

Replacement water heaters

Our original Knight range of gas-fired water heaters was launched in 1976, since when these products have been a popular water heater choice for many buildings. Our normal approach would be to encourage users to replace such models with higher efficiency condensing water heater models, but there are certain instances where this is not practical. For these reasons we have developed this Low NO_x range; they meet the most recent requirements of the Energy-related products directive and they provide installers and end users with a convenient and cost-effective option, when existing water heaters need replacement.



Cutaway view

Water heater construction

Enamel-lined steel is a tried and tested material for water heater products and enables the water heaters to operate at pressures of up to 8bar. Each vessel includes a sacrificial magnesium anode to provide cathodic protection. The burner is situated at the base of the unit and the flue way running through the centre of the vessel is baffled, increasing the amount of heat transfer into the water. The multifunctional control valve incorporates flame failure safety, operating thermostat and high limit thermostat.



Multifunctional Gas Valve

Flue installation

Knight water heaters can be installed on conventional/open flue systems.

Dimensional drawings

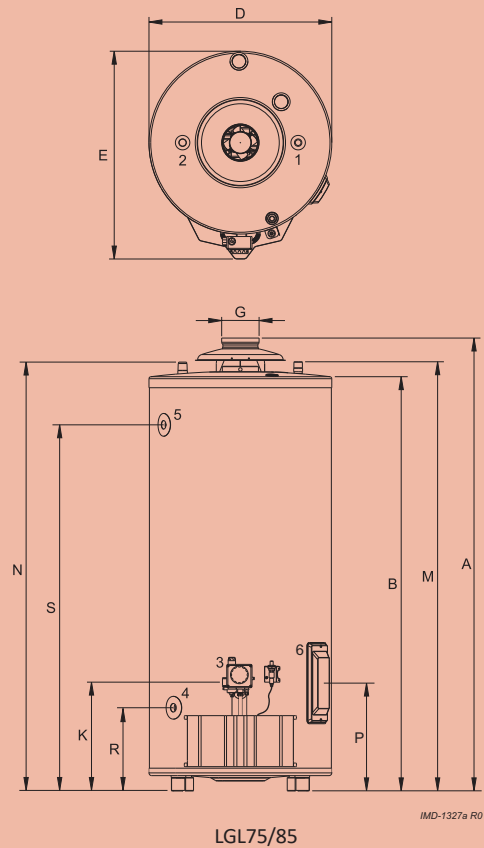
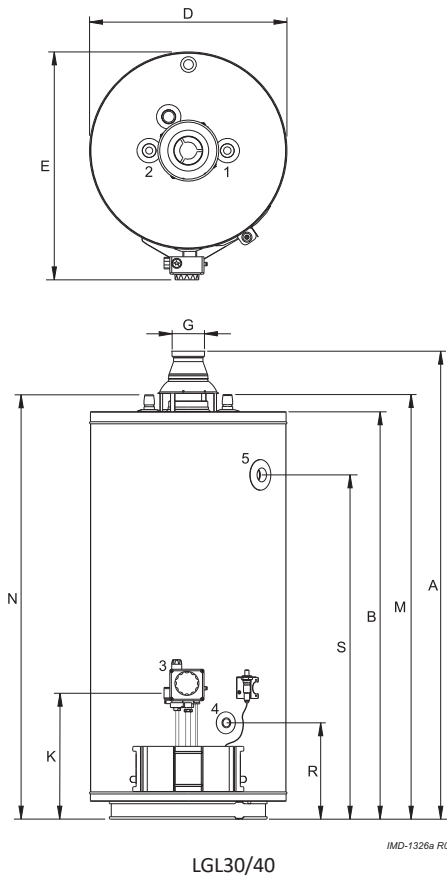

Model			LGL30	LGL40	LGL 75	LGL 85
A	Height (incl. draught diverter)	mm	1635	1380	1595	1780
B	Height	mm	1470	1220	1450	1660
D	Width	mm	405	560	645	705
E	Depth	mm	495	650	735	795
G	Flue gas outlet Ø	mm	80	80	130	130
K	Height gas connection	mm	335	335	385	375
M	Height cold water supply connection	mm	1530	1280	1510	1700
N	Height hot water outlet connection	mm	1530	1280	1510	1700
P	Height inspection opening	mm	N/A	N/A	370	360
R	Height drain valve connection	mm	250	250	300	295
S	T&P-valve connection	mm	1325	1050	1290	1475
1	Cold water supply connection (male)	NPT	¾	¾	1	1¼
2	Hot water outlet connection (male)	NPT	¾	¾	1	1¼
3	Gas control valve connection (female)	BSP	½	½	½	½
4	Drain valve connection (female)	NPT	¾	¾	¾	¾
5	T&P-valve connection (female)	NPT	¾	¾	¾	¾
6	Inspection opening	mm	n/a	n/a	105 x 135	105 x 135

Technical specification

Water heater model		LGL30	LGL40	LGL75	LGL85
Nominal input (net)	kW	8.6	10.1	19.9	18.9
Nominal input (gross)	kW	9.6	11.2	22.1	21.0
Gas flow rate (G20)	m ³ /hr	0.9	1.1	2.1	2.0
Nominal output	kW	7.6	8.6	16.8	16.6
Efficiency data - Building regulations					
Seasonal efficiency (gross CV)	%	79	77	76	79
Efficiency data - ErP and energy label					
Ecodesign energy label rating		B	B	B	C
Water heater efficiency	%	62	65	58	58
NO_x emissions					
NO _x emission according to EN89 @0% O ₂	mg/kWh	35	48	22	30
General data					
Recovery rate @ 44°C	l/hr	150	170	328	324
Recovery rate @ 50°C	l/hr	140	150	290	290
Recovery rate @ 56°C	l/hr	117	137	258	258
Dimensions (height to top of draft diverter)	mm	1635	1380	1595	1780
Dimensions (width)	mm	405	560	645	705
Dimensions (diameter)	mm	495	650	735	795
Storage capacity	litres	108	144	268	358
Weight (empty)	kg	49	56	124	151
Weight (full)	kg	157	200	392	509
Hot outlet connection (inches)	NPT	¾	¾	1	1¼
Cold feed connection (inches)	NPT	¾	¾	1	1¼
Gas connection (inches)	BSP	½	½	½	½
Flue connection	mm	80	80	130	130
Electrical requirements		n/a			
Power consumption (peak)	W	n/a	n/a	n/a	n/a
Sound power level	LWA(db)	55	55	55	55
Maximum flue gas temperature	°C	122	188	142	125
Max outlet temperature	°C	71	71	80	80
Maximum working pressure	bar	8	8	8	8

Energy label, product fiche and ErP data table are available at www.Lochinvar.Ltd.Uk

Ancillary options

- Unvented system kits
- De-stratification pump sets



For further information on the Knight Low NO_x water heater, including icm & user instructions and our full warranty terms and conditions, please visit our website: www.lochinvar.ltd.uk



8 Lombard Way, The MXL Centre, Banbury, Oxon, OX16 4TJ

Tel: +44(0) 1295 269 981, Fax: +44(0) 1295 271 640, Email: info@lochinvar.ltd.uk

www.lochinvar.ltd.uk

Lochinvar Ltd reserves the right to change specifications without prior notice

LOC_20_0004 | LGL | August 2020

