

EcoSable stainless steel storage-type gas-fired water heaters



- Recovery rates from 600-787 litres/hour
- Stainless steel storage vessel
- Efficiencies of up to 92%
- Up to 8 bar working pressure
- Small footprint
- 5-year storage vessel warranty



Lochinvar[®]
HIGH EFFICIENCY BOILERS & WATER HEATERS

Lochinvar

EcoSable stainless steel, storage-type water heaters

EcoSable is a two-model range of fully condensing gas-fired water heaters with hot water recovery rates of 600 and 787 litres per hour, based upon a temperature rise of 50°C. Both models have a storage capacity of 186 litres.

The principles of direct gas-fired water heaters are based upon low storage capacity but fast recovery of hot water, which is a well-established method of providing a reliable and efficient supply of hot water. EcoSable models are particularly suitable for installation in large domestic and small to medium-sized, commercial hot water demand applications.

In addition to the 5-year storage vessel warranty, EcoSable components are covered by a 2-year warranty.



EcoSable
2 models available



1. Stainless steel storage vessel

High quality material; no requirement for cathodic protection and can operate at up to 8bar working pressure. 5 Year warranty on storage vessel against leakage.

2. Submerged combustion chamber with spiral flue

Operates in almost continuous condensing mode during hot water demand periods

3. Low NO_x, pre-mix modulating gas burner

Matches output to demand providing highly efficient and quiet operation

4. Side mounted hot and cold recirculation tapplings

Easy connection for building circulation

5. Insulation

Insulated with non CFC foam for low stand-by loss (maintenance consumption value)

6. Service access

Two removable doors, located at the front of the water heater provide easy access for maintenance on gas burner and controls

7. LCD touchscreen display

Conveniently located for easy control of temperature settings and diagnostics.

A key feature of the EcoSable is the ability to operate at temperatures of up to 85°C.

Dimensional drawings

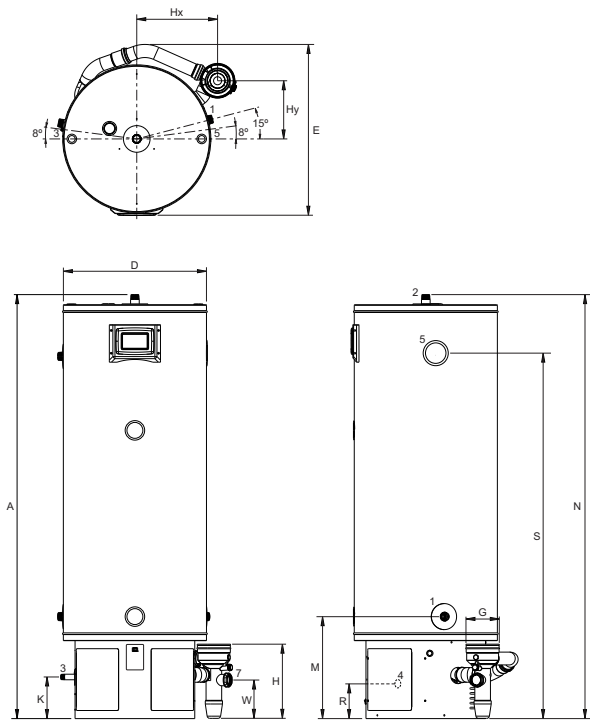

Model			LGSS 200-600GCE	LGSS 200-780GCE
A	Height (total height)	mm	1655	1655
D	Diameter	mm	560	560
E	Depth	mm	660	660
G	Air intake/flue gas outlet \varnothing	mm	80/125	80/125
1	Cold feed	NPT	1"	1"
2	Hot outlet	NPT	1"	1"
3	Gas	NPT	3/4"	3/4"
4	Drain valve	NPT	3/4"	3/4"
5	T&P valve	NPT	3/4"	3/4"
7	Condensate drain	mm	40	40

Ecosable flue options

EcoSable water heaters can be installed with horizontal or vertical concentric flue, twin pipe (parallel) or conventional flue.

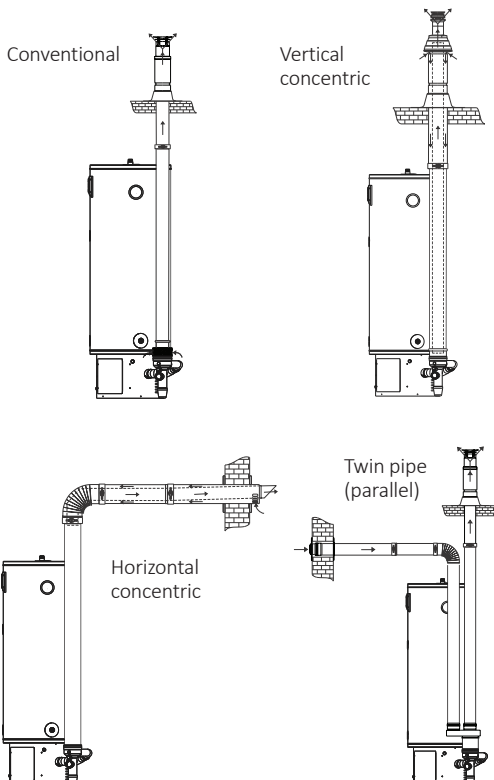

Concentric			LGSS 200-600GCE	LGSS 200-780GCE
Diameter	mm		80/125	80/125
Maximum length	m		20	20
Max. number of bends	m		5	5
Twin-Pipe			LGSS 200-600GCE	LGSS 200-780GCE
Diameter	mm		80	80
Maximum length	m		50	50

Further information on flue assemblies can be found in the installation, commissioning and maintenance manual and EcoSable flue guide documents; both are available at www.lochinvar.ltd.uk

Technical specification

Water heater model		LGSS200-600GCE	LGSS200-780GCE
Nominal input (net) min-max	kW	34.0	44.0
Nominal input (gross) min-max	kW	37.8	48.9
Gas flow rate (G20)	m ³ /hr	3.6	4.7
Nominal output min-max	kW	34.9	45.1
Efficiency data - Building regulations			
Seasonal efficiency (gross cv)	%	92.3	92.2
Maintenance consumption value	kW/24Hr	2.06	2.06
Efficiency data - ErP and energy label			
Ecodesign energy label rating		A	A
Water heater efficiency	%	93	91
NO_x emissions			
NO _x emission (weighted) @0% O ₂	mg/kWh	53	53
General data			
Recovery rate @ 44°C	l/hr	710	910
Recovery rate @ 50°C	l/hr	620	800
Recovery rate @ 55°C	l/hr	570	730
Dimensions (height)	mm	1655	1655
Dimensions (width)	mm	660	660
Dimensions (diameter)	mm	560	560
Storage capacity	litres	186	186
Weight (empty)	kg	79	79
Weight (full)	kg	261	261
Hot outlet connection (inches)	NPT	1"	1"
Cold feed connection (inches)	NPT	1"	1"
Gas connection (inches)	NPT	3/4"	3/4"
Flue connection (concentric)	mm	80/125	80/125
Flue connection (twin-pipe)	mm	80	80
Electrical requirements		230V /1Ph /50hz	
Power consumption (peak)	W	160	230
Sound power level	LWA(db)	63	69
Nominal flue gas temperature	°C	65	75
Max outlet temperature	°C	85	85
Maximum working pressure	bar	8	8

Energy label, product fiche and ErP data table are available at www.lochinvar.ltd.uk

Ancillary options

- Unvented system kits
- Condensate neutralisation kits
- Range of flue options (see page 3)



For further information on the EcoSable water heater, including ICM & user instructions and our full warranty terms and conditions, please visit our website: www.lochinvar.ltd.uk

