

EcoKnight circulating-type gas-fired water heaters



- Recovery rates from 709 to 3819 litres/hour
- Efficiencies up to 96.7%
- Fully modulating pre-mix burner
- Stainless steel heat exchanger
- High working pressure – up to 11 bar
- Low NOx emissions $\leq 40\text{mg/kWh}$
- Integral controls

Lochinvar EcoKnight circulating-type water heaters

EcoKnight gas-fired water heaters are available in 8 different models, with hot water outputs ranging from 709 to 3819 litres/hour, based upon a temperature rise of 50°C. As a circulating water heater, EcoKnight generates fast recovery hot water in the high efficiency stainless steel heat exchanger. This hot water is then transferred to a direct storage vessel or a multiple vessel arrangement, which in turn supplies the building hot water requirements.

This type of water heating method offers a great deal of flexibility, allowing multiple water heater and storage vessel combinations, providing a great deal of installation flexibility. This can be particularly useful where plant rooms have space limitations. The range utilises pre-mixed condensing technology, and offers a highly efficient water heating solution for a wide range of commercial and industrial hot water requirements.



EcoKnight water heater
8 models

Stainless steel heat exchanger

At the heart of the EcoKnight is a grade 316l stainless steel heat exchanger; this material provides superior resistance to corrosion. The coiled design of the heat exchanger allows for condensation to occur, creating high efficiency, particularly on initial heat up.

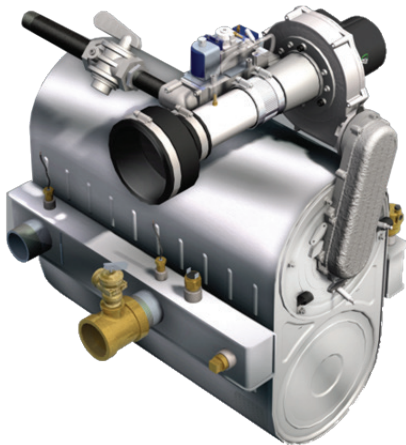

Fully modulating pre-mix burner with 5:1 turndown

All 8 EcoKnight condensing water heaters feature advanced gas/air ratio controlled combustion technology. This technology automatically adjusts fan speed according to demand, providing the optimum proportions of gas and air to enter the burner. The 5:1 turndown feature ensures that fuel consumption is matched from 20% to full demand. EcoKnight water heaters can therefore achieve high levels of efficiency as follows:-

- Seasonal efficiency (Part L2 gross CV) – up to 96.7%
- Seasonal efficiency (ErP/codesign) – up to 95%

Low NOx emissions

EcoKnight water heaters have low NOx emissions, ranging from 27 to 40 mg/kWh depending upon model, and therefore comply with the latest ErP Regulations dated September 2018.

Energy label

With rated outputs of 41 and 59kw respectively, models EKW46CE and EKW61CE are within the scope of the energy label directive – both models have “energy label A”

Note - EcoKnight water heaters are designed for installation with direct storage vessels (see pages 3 and 4). Energy label and ErP data on our range of direct storage vessels is available at www.lochinvar.ltd.uk.

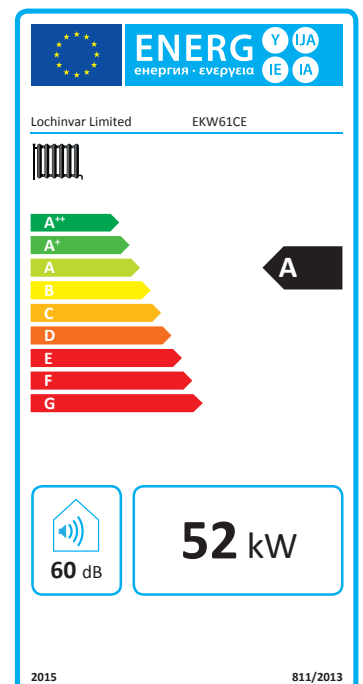
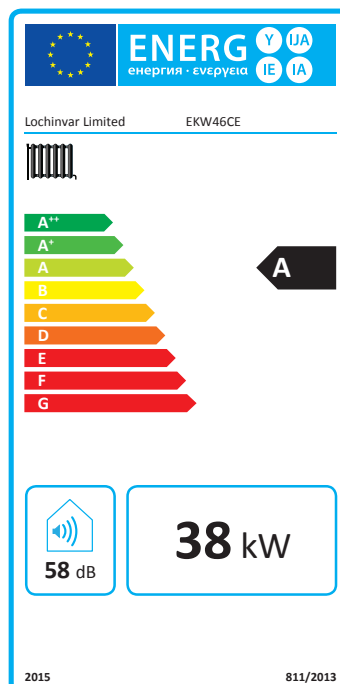

SMART system controls

EcoKnight water heaters have integral SMART system controls, which provide a wide range of settings without the requirement for a Building Management System (BMS), therefore providing a potential saving on capital cost. This advanced control system includes:

- Multi colour graphic LCD display
- Cascade management of up to 3 x EcoKnight Water Heaters
- Modulating pump control
- Night set back facility – which can also be used for a pasteurisation programme
- Ability to add contractor/service company details into the display

The facility to connect to BMS is also available with 0 to 10 volt connections being available for simple BMS connectivity which allows control of burner and set point



Flue options

A range of flue options are available including traditional conventional flue or room sealed concentric or twin pipe and with flue runs of up to 60m.

Maximum flue lengths

Model	Concentric		Twin-Pipe*		Conventional	
	Flue dia mm	Max. equivalent flue run	Flue dia mm	Max. equivalent flue run	Flue dia mm	Max. equivalent flue run
EKW46CE	80/125	30m	80-80	60m**	80	60m
EKW61CE	80/125	30m	80-80	60m**	80	60m
EKW86CE	100/150	30m	100-100	60m**	100	60m
EKW116CE	100/150	30m	100-100	60m**	100	60m
EKW146CE	N/A	N/A	150-150	60m**	150	60m
EKW176CE	N/A	N/A	150-150	60m**	150	60m
EKW206CE	N/A	N/A	150-150	60m**	150	60m
EKW236CE	N/A	N/A	150-150	60m**	150	60m

* Twin pipe flue assemblies can be supplied with single or separate terminals
 ** Combined length of air inlet and exhaust outlet

Direct storage vessels

Circulating water heaters are designed for installation with separate storage vessels; this provides a great deal of installation flexibility as multiple storage and hot water recovery combinations are available. Our LST and LST GE direct storage vessels are specifically designed for use with circulating water heaters and are available with storage capacities ranging from 297 to 2820 litres.

Key product features include :

- Enamelled steel construction
- Suitable for working pressures up to 8 bar
- Hand hole cleanout
- Tapping(s) for immersion heater back-up
- 5-year storage vessel warranty (model LST166)
- 3-year storage vessel warranty (all other models)

For further information on LST direct storage vessels, please visit www.lochinvar.ltd.uk



Primary circulation pump

It is particularly important to maintain a constant flow through the EcoKnight heat exchangers, therefore we offer a range of suitably sized circulating pumps



Typical schematic drawings

EcoKnight water heaters and storage vessel combinations provide a great deal of installation flexibility with multiple water heater/storage vessel options available to cover a wide range of water heating requirements

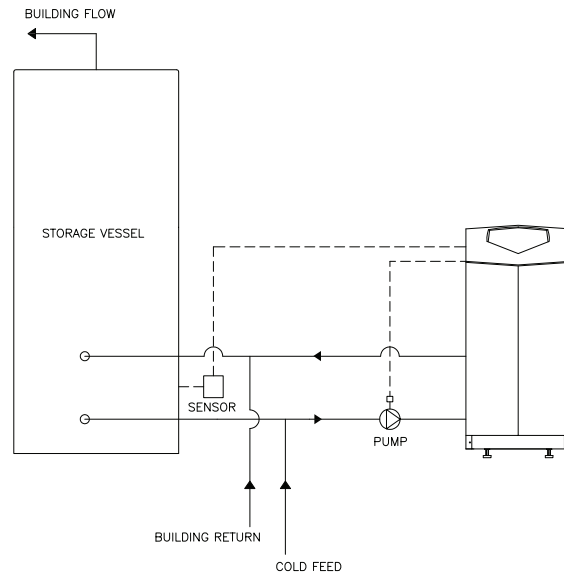

Single EcoKnight water heater with single LST direct storage vessel

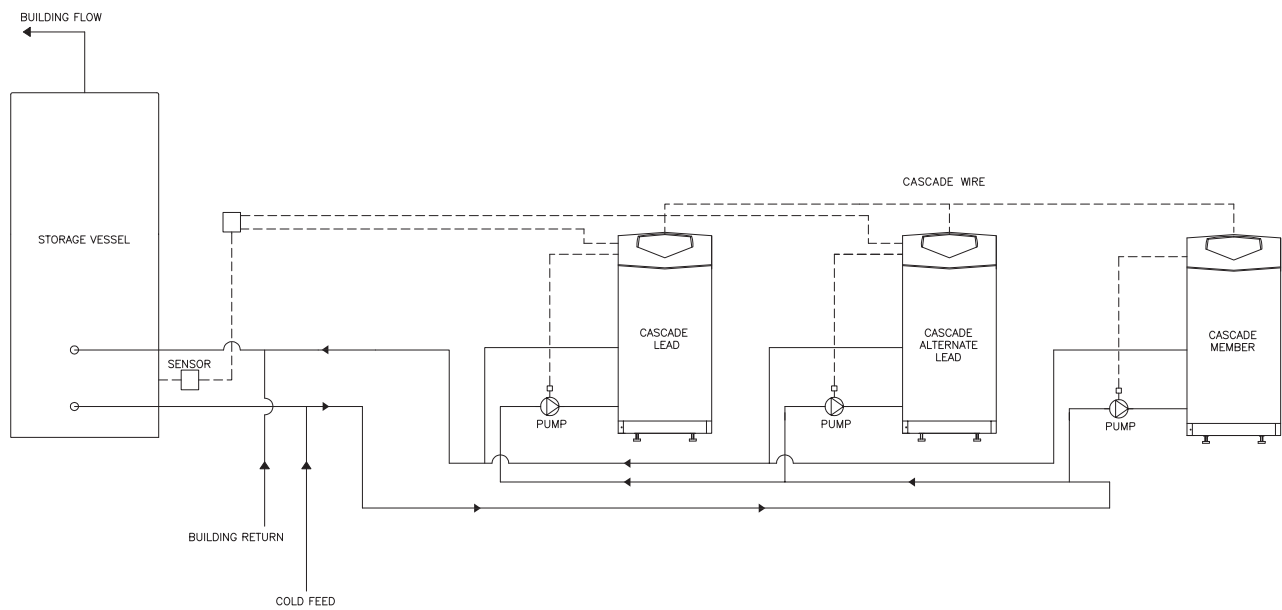

Three EcoKnight water heaters in cascade arrangement with single LST direct storage vessel

EcoKnight water heater – dimensions

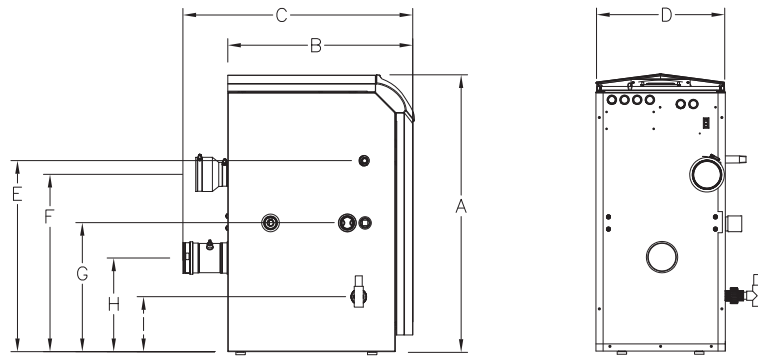

For models EKW46CE and EKW61CE

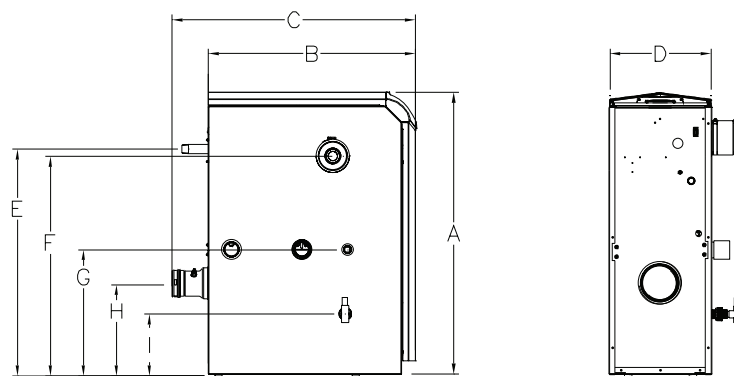

For models EKW86CE, EKW116CE, EKW146CE, EKW176CE, EKW206CE and EKW236CE

Description			Model							
			EKW 46CE	EKW 61CE	EKW 86CE	EKW 116CE	EKW 146CE	EKW 176CE	EKW 206CE	EKW 236CE
A	Height	mm	840	840	1080	1080	1080	1080	1080	1080
B	Depth	mm	459	567	503	688	798	925	1024	1153
C	Depth inc flue outlet	mm	599	707	715	828	938	1065	1164	1293
D	Width	mm	395	395	395	395	395	395	395	395
E	Gas connection	mm	582	582	788	860	887	833	833	834
F	Air inlet	mm	540	540	860	860	887	915	915	915
G	Water connections	mm	390	390	477	477	477	477	477	477
H	Flue outlet	mm	286	286	350	350	350	350	350	350
I	Condense outlet	mm	167	167	230	230	230	230	230	230

Technical specification

Water heater model		EKW 46CE	EKW 61CE	EKW 86CE	EKW 116CE	EKW 146CE	EKW 176CE	EKW 206CE	EKW 236CE
Nominal input (net)	kW	39.6	55.4	75.2	105.3	132.0	158.4	184.9	211.3
Nominal input (gross)	kW	44.0	61.5	83.5	116.9	146.5	175.8	205.2	244.2
Gas flow rate (natural gas)	m ³ /hr	4.2	5.9	8.0	11.1	14.0	16.8	19.6	22.3
Nominal output	kW	41.2	58.7	79.7	110.6	141.2	162.1	187.4	227.2
Efficiency data - building regulations									
Seasonal efficiency (gross CV)	%	93.6	95.4	95.4	94.6	96.4	92.2	91.3	93.0
Efficiency data - ErP and energy label									
Ecodesign energy label rating		A	A	n/a	n/a	n/a	n/a	n/a	n/a
Seasonal space heating energy efficiency	%	95	94	94	93	94	95	95	95
NO_x emissions									
NO _x emissions (according to EN15502) @0% O ₂	mg/kWh	33.0	27.3	33.1	40.0	38.0	37.0	34.0	32.5
NO _x class according to EN15502		6							
General data									
Recovery rate @ 44°C	l/hr	806	1153	1567	2164	2768	3302	3865	4338
Recovery rate @ 50°C	l/hr	709	1014	1379	1904	2436	2905	3401	3819
Recovery rate @ 56°C	l/hr	633	906	1231	1700	2175	2595	3037	3409
Dimensions (height)	mm	840	840	1080	1080	1080	1080	1080	1080
Dimensions (width)	mm	395	395	395	395	395	395	395	395
Dimensions (depth)	mm	459	567	503	688	798	925	1024	1153
Water content	litres	4.9	6.4	9.1	12.9	15.9	15.9	18.9	21.6
Weight (empty)	kg	75	79	102	129	138	154	168	184
Weight (full)	kg	80	85	111	142	154	170	187	206
Flow connection (inches)	BSP	1½"	1½"	2"	2"	2"	2"	2"	2"
Return connection (inches)	BSP	1½"	1½"	2"	2"	2"	2"	2"	2"
Gas connection (inches)	BSP	½"	½"	¾"	1"	1"	1"	1"	1"
Flue connection (concentric)	mm	80/125	80/125	100/150	100/150	n/a	n/a	n/a	n/a
Flue connection (twin-pipe)	mm	80/80	80/80	100/100	100/100	150/150	150/150	150/150	150/150
Electrical requirements		230V/1ph/50Hz							
Power consumption	W	120	144	180	180	204	322	322	322
Sound power level	LWA(dB)	58	60	62	64	66	69	69	69
Nominal flue gas temperature	°C	120	120	120	120	120	120	120	120
Max outlet temperature	°C	88	88	88	88	88	88	88	88
Working pressure minimum	bar	0.5	0.5	0.5	0.5	0.5	0.5	0.5	0.5
Working pressure maximum	bar	11	11	11	11	11	11	11	11

Energy label, product fiche and ErP data table are available at www.lochinvar.ltd.uk

Ancillary items – required

- Matched primary circulation pump
- Direct storage vessels

Ancillary items – optional

- Unvented system kits
- Condensate neutralisation kit
- Range of flue options (see page 3)
- BMS Interface Module

For further information on the EcoKnight water heaters, including ICM & user instructions and our full warranty terms and conditions, please visit our website: www.lochinvar.ltd.uk



Lochinvar Ltd reserves the right to change specifications without prior notice