

The LOK Range

Packaged Plate Heat Exchangers for
Domestic Hot Water Production

Installation, Commissioning and Maintenance Instructions

Models:

LOK8-50/LOKT8-50

LOK8-100/LOKT8-100

LOK8-150/LOKT8-150

LOK8-200/LOKT8-200

LOK8-250/LOKT8-250

LOK8-300/LOKT8-300

LOK8-350/LOKT8-350

LOK8-400/LOKT8-400

LOK14-450/LOKT14-450

LOK14-500/LOKT14-500

LOK14-550/LOKT14-550



BLANK PAGE

Document	Version	Date	Updated by
LOK Packaged plate heat exchanger ICM	December 2023	12/23	SJA

1.0	INTRODUCTION	3
2.0	ANCILLARY OPTIONS:	3
3.0	DATA TABLES	3
3.1	LOK8 AND LOKT8 (TWIN HEADED PUMP) MODELS	4
3.2	LOK14 AND LOKT14 (TWIN HEADED PUMP) MODELS	5
4.0	INSTALLATION	6
4.1	LIFTING:.....	6
4.2	LIFTING POINTS TO AVOID:	6
4.3	MAINTENANCE SPACE:.....	6
4.4	LEAKAGE:.....	6
4.5	SAFETY:.....	6
4.6	WELDING:.....	6
5.0	PRIMARY SHUNT PUMPS:	7
5.1	DHW SHUNT PUMP:	7
6.0	WATER QUALITY:	7
7.0	WATER CONNECTIONS:	7
8.0	PIPEWORK:	7
9.0	SENSORS:	8
9.1	INSTANTANEOUS WATER HEATING: See figure 2	8
9.2	STORAGE VESSELS: See figure 3	8
10.0	ELECTRICAL INSTALLATION:	8
11.0	SCHEMATICS:	11
11.1	Legend for schematics	11
12.0	COMMISSIONING:	15
12.1	4 PORT VALVE – CAST IRON BODY TYPE	15
12.2	CONTROL VALVE OPERATION:	16
12.3	SETTING UP THE CONTROLLER AND START UP:.....	16
12.4	OPERATION IN AUTOMATIC MODE:	16
12.5	CLEANING OF THE PLATES:.....	17
13.0	RE-ASSEMBLY OF THE HEAT EXCHANGER:	17
14.0	TIGHTENING OF THE PLATE PACK:	18
15.0	FAULT FINDING:	20
15.1	HEAT EXCHANGER PLATE PACK ASSEMBLY:	20
15.2	EXCESSIVE PRESSURE DROPS:	20
15.3	LEAKAGE:.....	20
15.4	DECREASE IN THE PERFORMANCE:	20
15.5	NO SECONDARY FLOW:	21
15.6	SECONDARY WATER TEMPERATURE INCORRECT, OR UNIT CUTS OUT ON OVER HEAT	21
15.7	CONTROL VALVE MAINTENANCE - CAST IRON VALVE TYPE:	22
15.8	CONTROL VALVE MAINTENANCE - BRASS VALVE TYPE:	22
16.0	PRIMARY OR SECONDARY PUMP FAILS TO OPERATE:	22
17.0	ACTUATOR REPLACEMENT:	23
18.0	PLANNED MAINTENANCE:	23
19.0	WARRANTY:	23

1.0 INTRODUCTION

- The unit is designed to heat domestic hot water (DHW) using low temperature hot water (LTHW). The primary circulating shunt pump mounted on the unit is for heat exchanger control only and is sized to pump the correct volume of LTHW through the heat exchanger to ensure efficient operation.
- When domestic hot water is required, the control valve modulates to allow LTHW to be pumped through the exchanger. The required DHW outlet temperature can be set on the controller.
- The temperature of the DHW is monitored by the strap-on sensor on the DHW outlet pipe. This sends a signal to the controller in the panel that in turn modulates the control valve thereby maintaining the DHW outlet temperature set on the controller.
- If the DHW temperature rises above the safety temperature limit, an overheat thermostat will shut down the primary circulating pump (and also the secondary pump if fitted and controlled by the panel). The system can only be re-started when the temperature has cooled down and after the high temperature re-set button has been pushed on the front of the panel.
- To avoid the possibility of thermal siphoning back from the boiler return, we recommend that non return valves are incorporated into the pipe-work. Due to the high efficiency of the heat exchanger when there is no DHW circulation it is possible to overheat the DHW and cause the overheat thermostat to activate even when the primary shunt pump is not running

2.0 ANCILLARY OPTIONS:

REMOTE OPERATION:

As an additional option the unit can be supplied with a remote on/off allowing control via a Building Management System or external time clock.

During control times / schedules, the pump(s) run continuously.

When in external control (via remote on/off, external time clock or BMS system) only the operation of the pump(s) is controlled. The high temperature over heat protection and the control of the modulating valve is independent of external control

Four port valves are fitted as standard to all of the models in the range. Advantages of a four port valve are that it allows the LTHW circulation to be maintained to and from the unit at all times. This:

- Avoids cold pipe work when exchanger not calling for heat
- Allows any other boiler safety & control functions to continue (such as over runs, etc)
- Enables the exchanger to be connected into the main primary loop rather than from a “tapping” into the main primary flow and return.

3.0 DATA TABLES

3.1 LOK8 AND LOKT8 (TWIN HEADED PUMP) MODELS

LOK8/LOKT8 MODEL	50	100	150	200	250	300	350	400
Duty (kW)	50	100	150	200	250	300	350	400
Thermal efficiency (%)	99.5							
Maximum primary temperature (°C)	99							
Maximum secondary temperature (°C)	85							
Number of plates	8	14	22	30	34	38	44	47
Recovery @50°C l/hr	864	1728	2628	3492	4320	5184	6048	6948
Recovery @50°C l/s	0.24	0.48	0.73	0.97	1.2	1.44	1.68	1.93
Pressure drop secondary side (bar)	0.18	0.18	0.15	0.15	0.17	0.19	0.2	0.21
Max working pressure (bar)	10							
Electrical Requirements	230V /1Ph/ 50hz							
Physical Dimensions and weights								
Dry weight-single head pump (kg)	110	113	116	119	122	124	127	127
Dry weight-twin head pump (kg)	128	131	135	137	140	142	145	145
Frame width (mm)	643							
Frame length (mm)	1023							
Frame height (mm)	1445							
Connection sizes								
Primary Inlet (BSPT FEMALE)	1¼"							
Primary Outlet (BSPT FEMALE)	1¼"							
Secondary Inlet (BSPT MALE)	1¼"							
Secondary Outlet (BSPT MALE)	1¼"							

3.2 LOK14 AND LOKT14 (TWIN HEADED PUMP) MODELS

LOK14/LOKT14 MODEL	450	500	550
Duty (kW)	450	500	550
Thermal efficiency (%)	99.5		
Maximum design temperature primary (°C)	99		
Maximum design temperature secondary (°C)	85		
Number of plates	25	28	31
Recovery @50°C l/hr	7812	8676	9504
Recovery @50°C l/s	2.17	2.41	2.64
Pressure drop secondary side (bar)	0.16	0.17	0.17
Maximum working pressure - primary side (bar)	6		
Electrical Requirements	230V /1Ph/ 50hz		
Physical Dimensions and weights			
Dry weight-single head pump (kg)	189	191	194
Dry weight-twin head pump (kg)	210	212	214
Frame width (mm)	643		
Frame length (mm)	964		
Frame height (mm)	1541		
Connection sizes			
Primary Inlet	DN40 PN6 Flange		
Primary Outlet	DN40 PN6 Flange		
Secondary Inlet (BSPT MALE)	2"		
Secondary Outlet (BSPT MALE)	2"		
LOK ICM Data table_ November 2020			

4.0 INSTALLATION

4.1 LIFTING:

Exercise extreme caution at all times when lifting

Do not lift with the secondary shunt pump attached.

Lift from underneath if still on a base (pallet).

Lift off pallet using the lifting hole on the top at the plate heat exchanger (LOK14 only), or by attaching slings under or through the base plate – ensure unit is steadied during manoeuvring. It is possible to lift from the top frame bar of the heat exchanger (LOK14 only) to steady the assembly – however, do not lift from the frame bar without using the lifting hole / from the base, as well.

It is also possible to attach a strap or sling around the top flanged connection pipe at F1 location (goes out to the control valve) for steadying purposes only – do not lift from this point – use only to steady the unit whilst lifting from other areas.

4.2 LIFTING POINTS TO AVOID:

Avoid lifting from the stainless steel threaded connections, control panel, pump, valves, or any of the pipework and fittings not mentioned above.

4.3 MAINTENANCE SPACE:

Leave a minimum of double the width of the exchanger, either side of the unit, to allow for access to the exchanger tie bolts, and to allow for removal of the heat transfer plates.

4.4 LEAKAGE:

Gasketed Plate Heat Exchangers do have the potential to leak at some time during their life. Therefore, to avoid damage to plant room floor, electrical conduits etc., we recommend that a drip tray is placed underneath the plate pack.

4.5 SAFETY:

If the unit is to operate near personnel, we recommend that a metal spray shield is located over the gasketed plate pack in case of “blow out”. This would avoid scalding. The surfaces of the unit, pump, valve, and pipe work become hot during operation – ensure that adequate consideration is given to personnel to protect them from burns when deciding upon the location of the unit.

Pressure – it is essential that the exchanger, as with all pressure containers, is protected from the effects of any over-pressurisation should a fault in the operation of the system arise. Provision of suitable pressure relief devices such as relief valves, or bursting disks should be considered – positioned local to the exchanger, with no control or isolating valves between the device and the exchanger.

4.6 WELDING:

Do not weld near to or on the heat exchanger or associated components.

5.0 PRIMARY SHUNT PUMPS:

The pump supplied and fitted to the plate heat exchanger is for use to overcome the resistance of the plate heat exchanger and **should not be used** as the Primary DHW pump. The pumps rely on water for cooling and lubrication. Damage will be caused if the pumps are run on a dry system

5.1 DHW SHUNT PUMP:

If a DHW pump is supplied loose, the direction of the pump must be so that the water flows into the top right hand side connections (F2). Do not fit this pump until the unit has been installed in its final position. This pump must be fitted with adequate supports so that no strain is put upon the heat exchanger connections.

6.0 WATER QUALITY:

It is **essential** to treat/soften the DHW prior to heating to reduce the build-up of scale in the heat exchanger. Consult with a water softening specialist to determine the best method of treatment for the water in your area.

With this in mind, it is of utmost importance when installing the water heater that adequate measures are taken to prevent scaling of the heat exchanger plates and waterways.

Water supply quality may adversely affect the efficiency and performance of plate heat exchangers and hot water systems. The situation can intensify where higher temperatures or demands exist. It is imperative that regular inspection of the plates and waterways be undertaken to assess the level of scale build up. Deposits of scale must be removed by suitable means.

7.0 WATER CONNECTIONS:



See section [SCHEMATICS](#): before starting installation of pipework

Use two wrenches when attaching unions to the domestic water circuit threaded stub connections. One wrench to be used to tighten the union & the other to prevent the stub end from rotating – this avoids damage to the gasket inside the unit that seals against the back on the stub connection. Use a non hardening thread sealant for best results. Threads are BS21 – taper, male. It is necessary to support the secondary pump and the pipework as the heat exchanger connections are not designed to accept any weight being imposed upon them.

8.0 PIPEWORK:

To avoid damage to the unit, prevent failure and to ease maintenance, we recommend the following:

- Pipework - fully support to avoid weight/forces acting upon the unit / connections.
- The fitting of flexible couplings if the pipe work is subject to vibration.
- The pipe work is completely flushed before attaching to exchanger. The exchanger acts as an effective filter and will become blocked if pipe-work debris is allowed to enter the plate pack.
- The fitting of suitable vents, isolation valves & drains. To allow servicing of the package without complete system draining appropriate isolation valves should be fitted.
- The fitting of non-return valves where appropriate
- The fitting of suitably sized pressure relief valves in the pipe work on both circuits (essential safety requirement).

9.0 SENSORS:

There are two temperature sensors – one for control and the other for overheat protection.

Both sensors are of the strap on type, they both need to be attached tightly to the pipework. If steel pipework is used, then for best results we recommend that a section of steel pipe is replaced by copper and the sensors attached to this section of copper. Depending on how the LOK unit is used will determine the sensor positions;

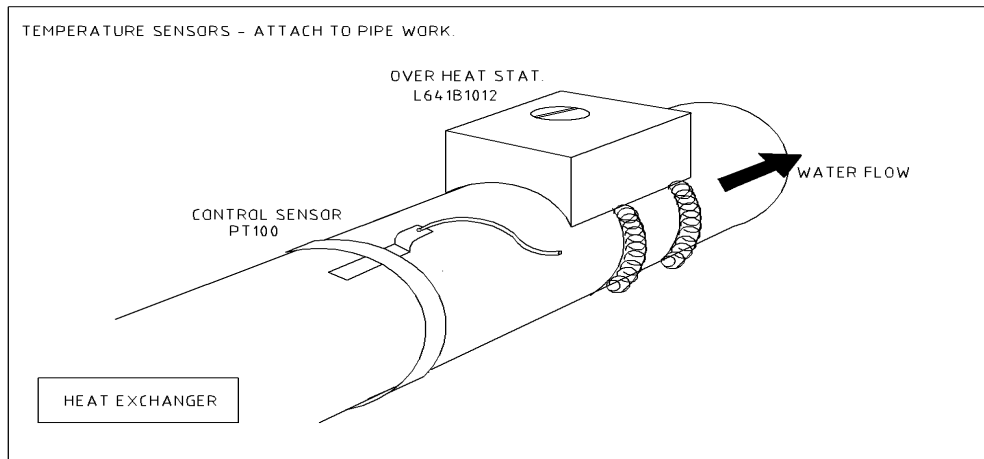

9.1 INSTANTANEOUS WATER HEATING: See figure 2

Both sensors should be connected to the secondary flow pipe work going to the services (flow from F3 connection). The control sensor needs to be attached to the pipe between 250 to 500 mm away from the exchanger, and the overheat thermostat located just after the control sensor. Route and clip the wires as necessary – do not attach any wires near, or onto the tie bolts, or along the length of the top horizontal frame bar of the heat exchanger.

9.2 STORAGE VESSELS: See figure 3

Both sensors should be connected to the secondary return pipe from the vessel connecting back to the inlet side of the LOK unit – this will then correctly measure the temperature within the storage vessel. Both sensor needs to be attached to the pipe within 250 to 500 mm from the storage vessel. Route and clip the wires as necessary – do not attach any wires near, or onto the tie bolts, or along the length of the top horizontal frame bar of the heat exchanger.

10.0 ELECTRICAL INSTALLATION:

Electrical supply required is 230V /1Ph/ 50hz

Connect the supply cable to the panel using a suitable isolation switch protected by a fuse or MCB rated at no more than 16A. The only connections required are the supply to the panel together with connection of secondary pump(s) if applicable. When a secondary pump is supplied with the package, the pump control cables are installed at the factory and clearly marked. They should be connected to the pump only after the pump has been fitted to the pipe work. All other wiring is carried out at the factory. All wiring must be carried out by suitably qualified personnel in line with current regulations.



Control panel wiring diagrams are supplied and shipped within the control panel enclosure. If replacement drawings are required, the Plate Heat Exchanger's serial number must be quoted as all units are built to order.

PORT	CONNECTION TYPE	FUNCTION
V1	1¼" BSPT FEMALE	BOILER RETURN
V4	1¼" BSPT FEMALE	BOILER FLOW IN
F2	1¼" BSPT MALE	DHW COLD IN
F3	1¼" BSPT MALE	DHW HOT OUT

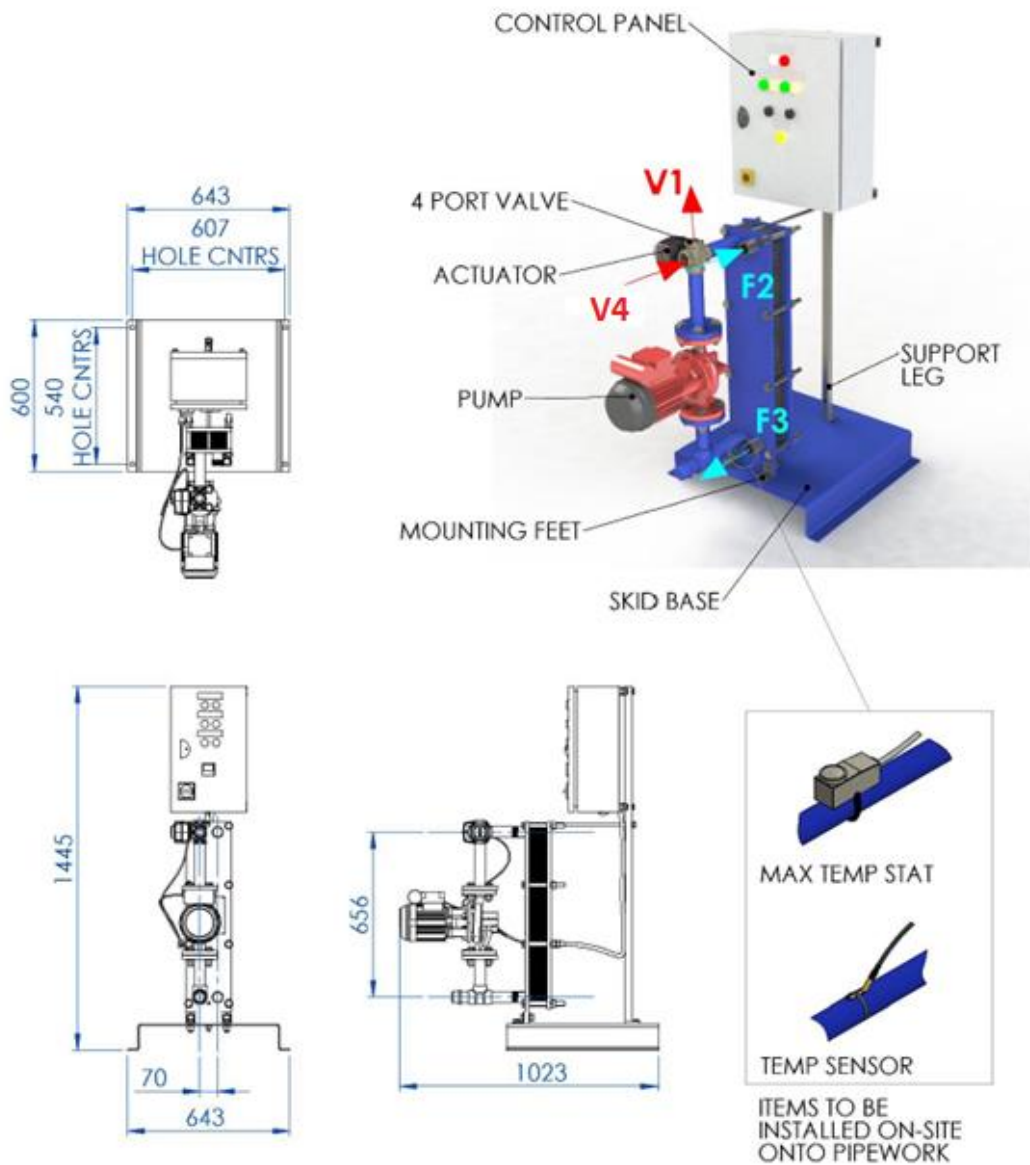

FIGURE 1:

PIPEWORK CONNECTIONS AND FUNCTIONS LOK8 RANGE

PORT	CONNECTION TYPE	FUNCTION
V1	DN40/PN6 FLANGED	BOILER RETURN
V4	DN40/PN6 FLANGED	BOILER FLOW
F2	2" BSPT MALE	DHW IN
F3	2" BSPT MALE	DHW OUT

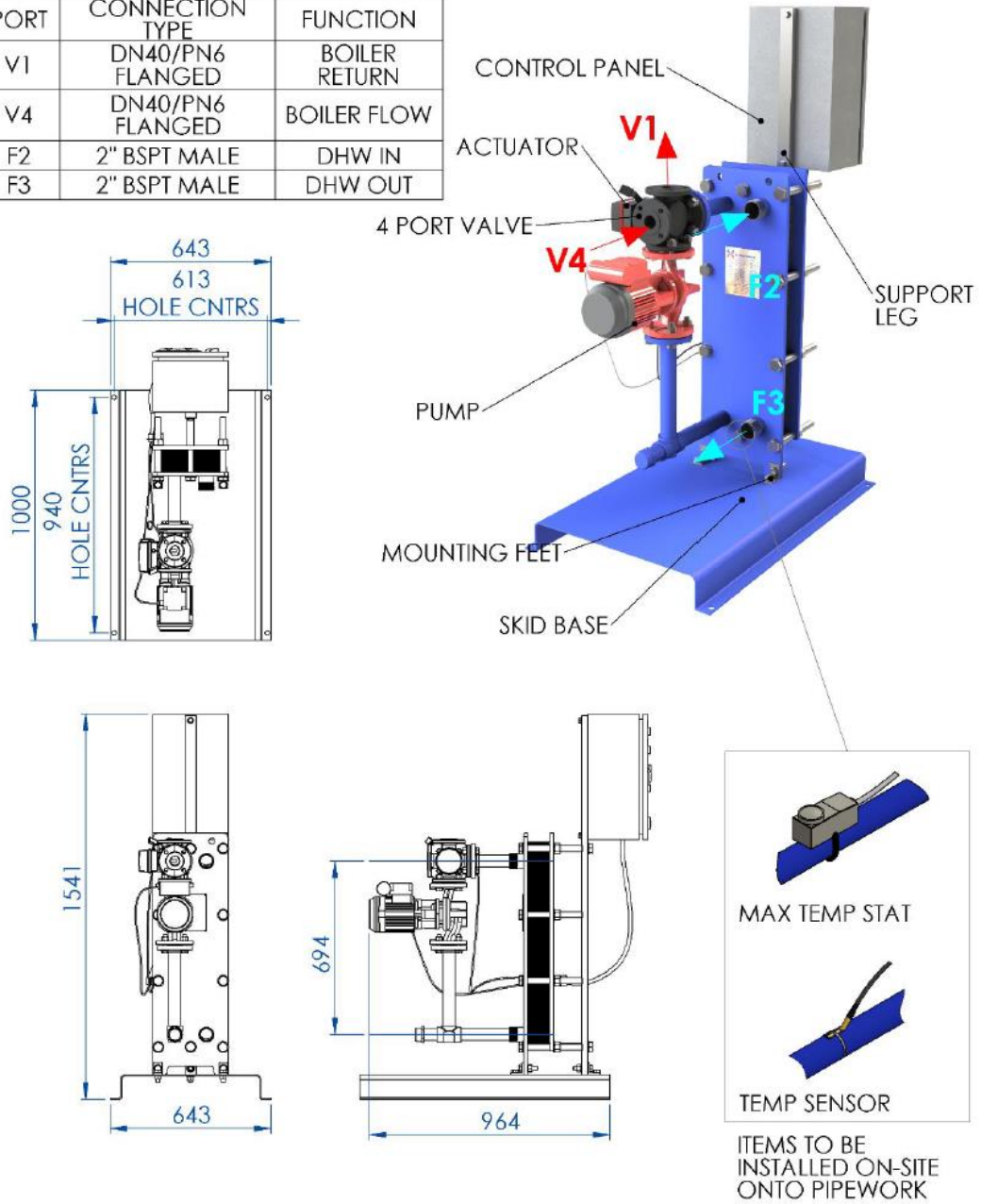

FIGURE 2: PIPEWORK CONNECTIONS AND FUNCTIONS LOK14 RANGE

11.0 SCHEMATICS:



Lochinvar limited may provide technical advice and guidance to assist with best practice, optimisation, and installation of Lochinvar products; however, we will not be liable for any duties as designers under construction (design and management regulations 2015). In all cases where information is provided, the customer must assess and manage risks associated with the technical information and advice provided.



The pump installed on the LOK unit is designed to pull water from the heating circuit to the primary side of the plate, a separate primary DHW pump will need to be supplied and installed to feed the LOK unit from the primary LTHW header.(as shown in figure 3 and 4)

11.1 Legend for schematics

IV	ISOLATION VALVE
LSV	LOCK-SHIELD VALVE
NRV	NON-RETURN VALVE
PRV	PRESSURE REDUCING VALVE
EV	EXPANSION VALVE
EXV	EXPANSION VESSEL
BRP	BUILDING RETURN PUMP
CP	CIRCULATING PUMP
DV	DRAIN VALVE
TD	TUNDISH
CS	CIRCULATING SENSOR
OH	OVERHEAT SENSOR
LVH	LOW VELOCITY HEADER
TPRV	TEMPERATURE AND PRESSURE RELIEF VALVE

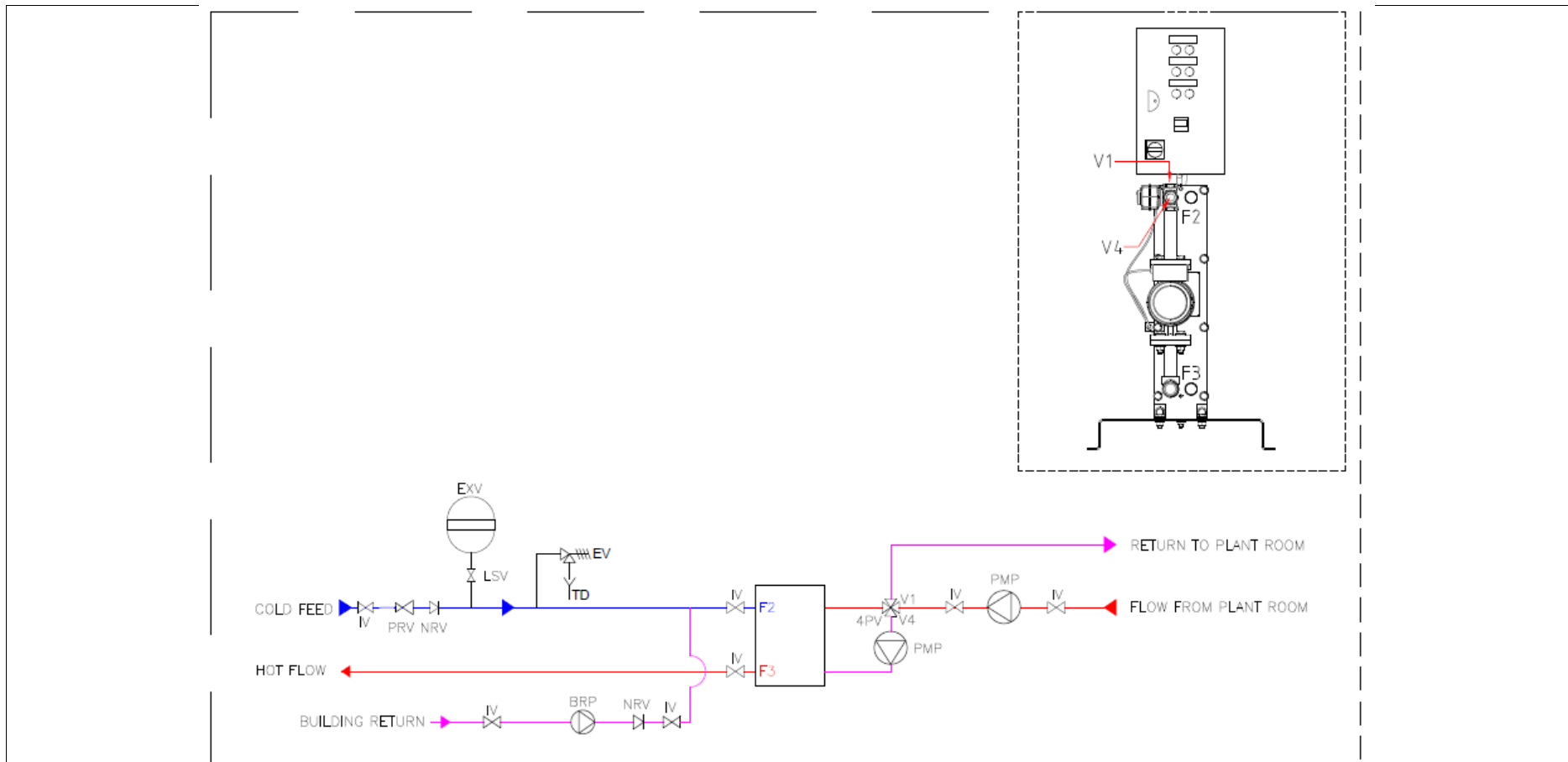

FIGURE 3: PLATE HEAT EXCHANGER INSTANTANEOUS WATER HEATING

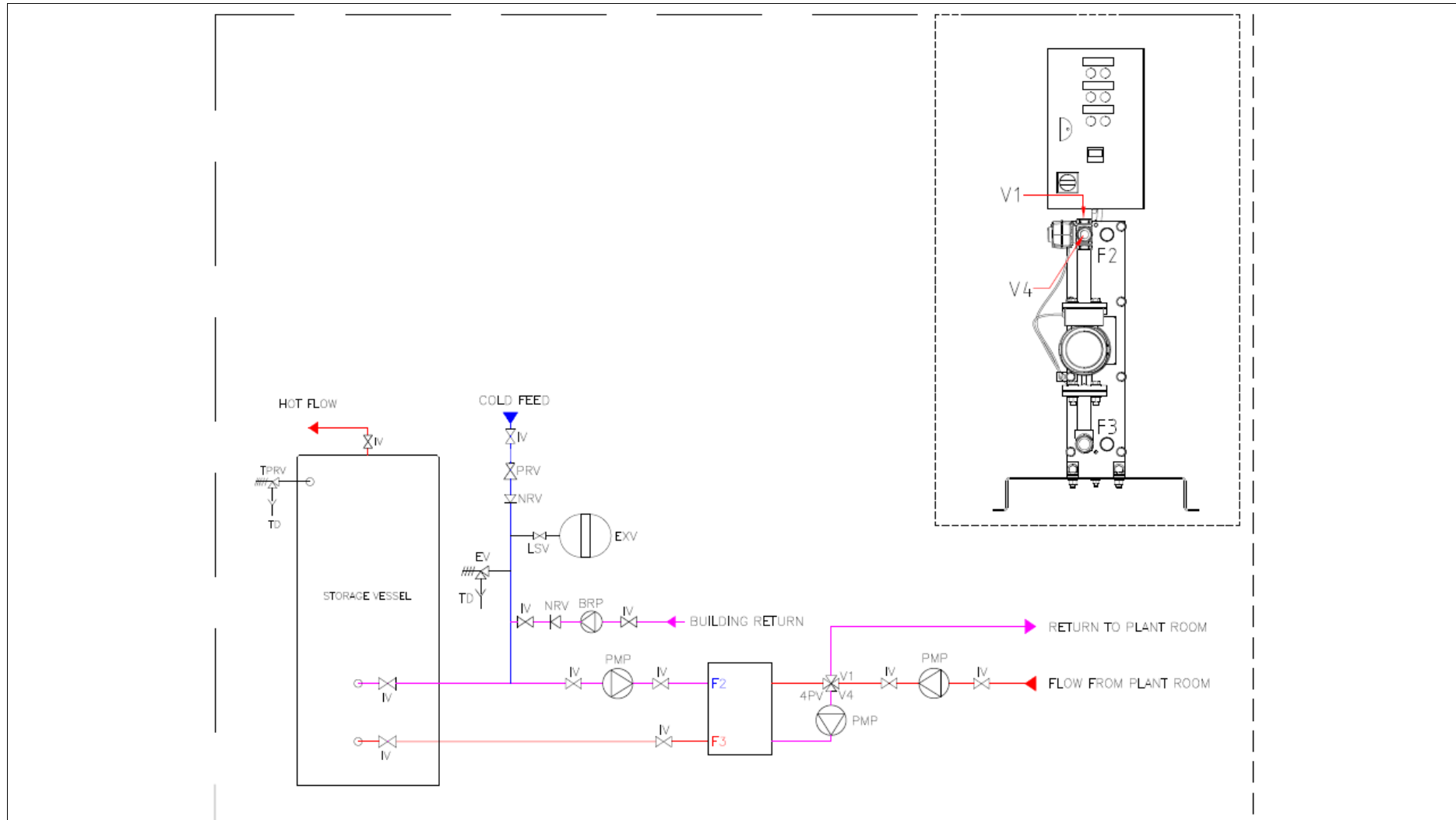
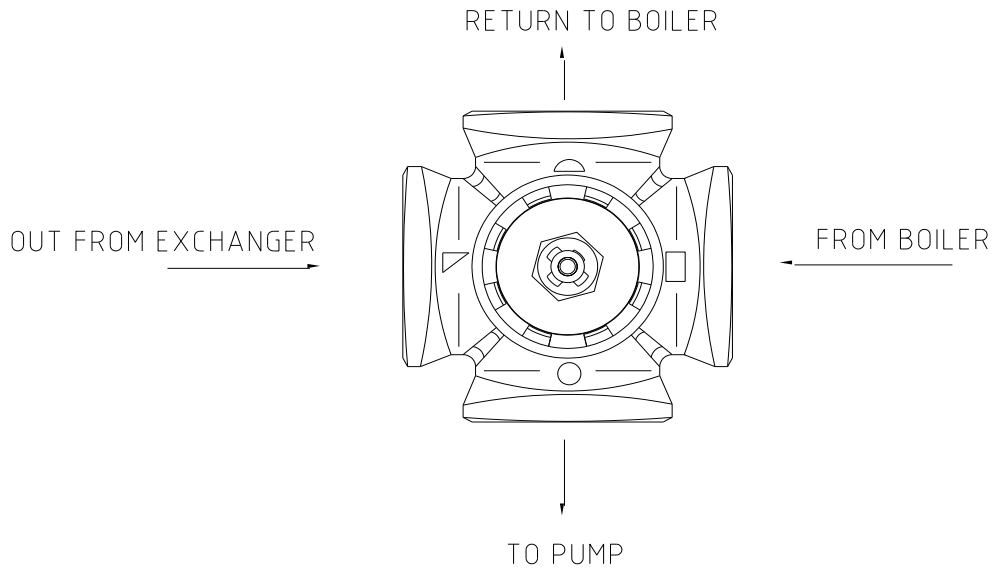

FIGURE 4: PLATE HEAT EXCHANGER AND STORAGE VESSEL DHW PRIORITY

:- 4 PORT VALVE :-

Details of setting up the 4 port valve - type ESBE VRG141



If actuator removed, then rotate the valve stem until the "notch" on the stem is pointing vertically upwards as shown

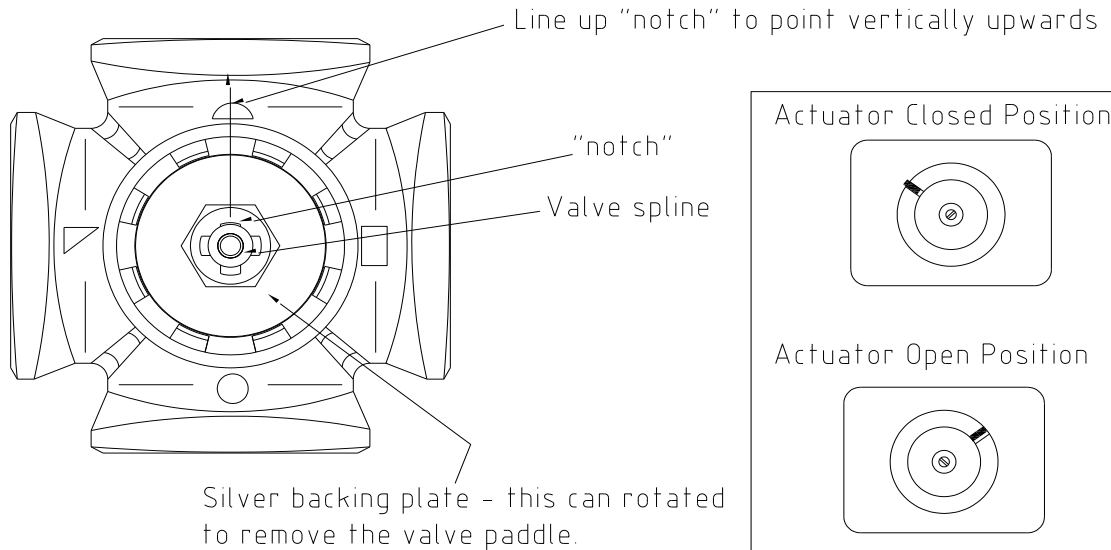

Once valve in this position, turn valve stem 45 degrees clockwise (valve should stop). Switch on control panel & set temperature to 70 Deg C - actuator should move clockwise until it stops. Slip actuator onto end of valve shaft and tighten central set screw. There is a locating dowel that protrudes out of the valve that needs to lock into the back of the actuator before tightening the central screw). Re-set temperature to desired position on panel.

When valve / actuator in fully open position, then the heat exchanger is on maximum demand. When valve/actuator in fully closed position, then there is no / minimal heating of secondary water.

12.0 COMMISSIONING:



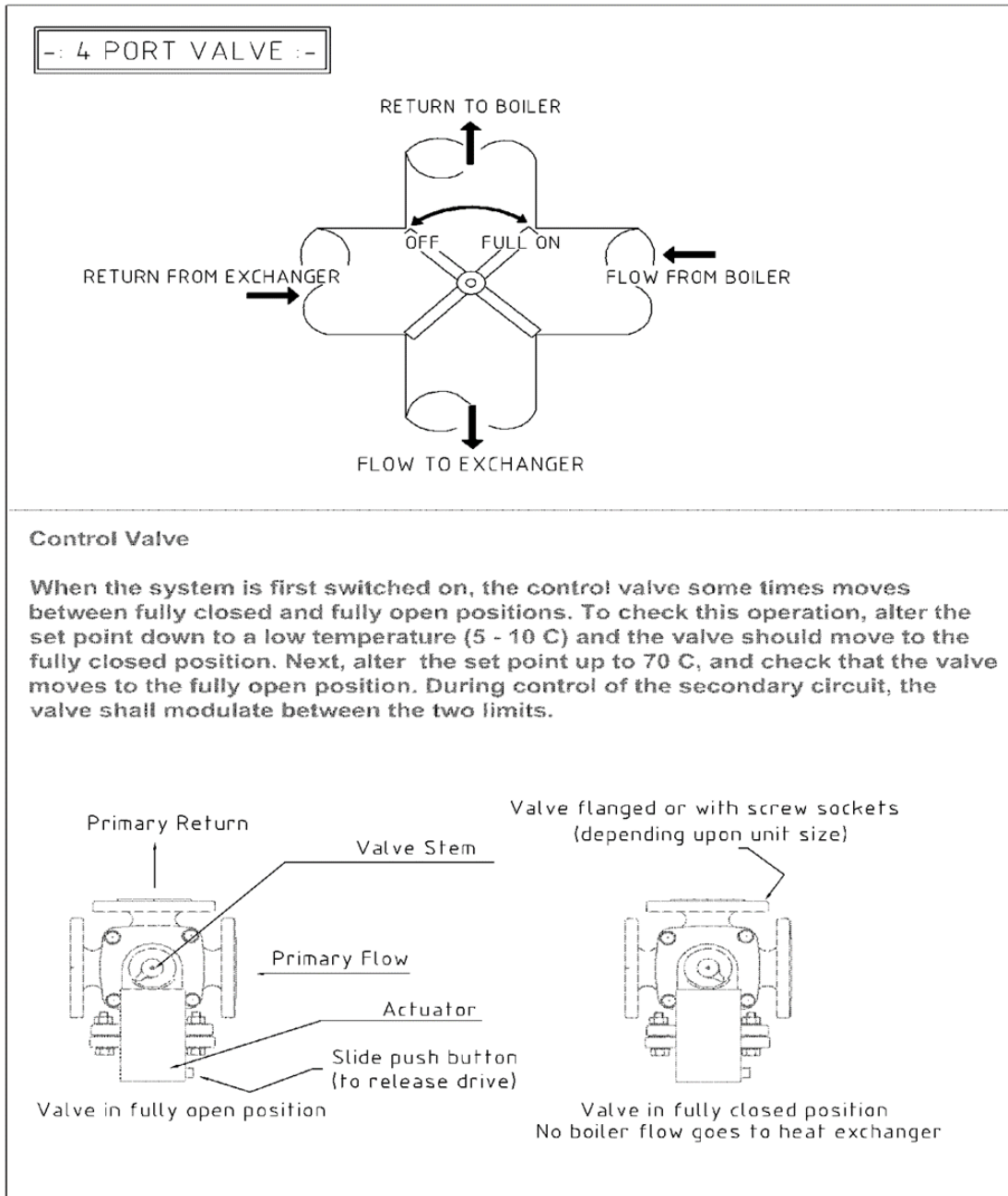

12.1 4 PORT VALVE – CAST IRON BODY TYPE

Before use, or if the system has been drained down for a period of time, it is important to check the operation of the valve – push the button slide forward on the side of the actuator – this frees the actuator drive from the valve – then rotate the valve stem from left to right (or right to left – depending upon where the valve is positioned), whilst continuing to hold the slide button forward (releasing the button locks the actuator drive back to the stem, thus preventing manual rotation). The valve stem should rotate for about 90 degrees before coming to a stop. The valve-stem should move relatively easily – if not, then check that slide button is being pushed forward enough, and try again. If the stem still cannot be rotated, then spray a suitable release oil into where the valve stem goes through the valve body.



12.2 CONTROL VALVE OPERATION:

Once filled with water, and before use, or if the system has been drained down for a period of time, it is important to check the operation of the valve – switch on the control panel and set the temperature to a high level (temperature altered by raising the set point). This is done by:

- Press  which is to the right of the temperature display.
- The lower display will then show “SP” and the upper display will show the actual set point.
- Press  or  to change the set point to the required value.
- Finally, press  to return to normal run mode.

The actuator should slowly rotate clock wise until the valve is at the “2 o'clock” position and then stop. Now lower the temperature (below ambient), and the actuator should rotate anti-clockwise and stop at around the “10 o'clock” position. If the actuator does not move, or does not turn full travel, then switch off at the panel by turning the isolation knob in the panel door. Pull out central knob of actuator slightly (this exposes orange sleeve) – this frees the actuator- drive from the valve. Then rotate the knob from left to right (or right to left – depending upon where the valve is positioned). The valve stem should rotate for about 90 degrees before coming to a stop. The valve stem should move relatively easily. If the stem still cannot be rotated, then valve has seized. Remove actuator and spray suitable release oil into where the valve stem goes through the valve body and then try rotating valve using a suitable wrench on the end of the stem.

Re-setting actuator – the central knob can only be pushed back in when the valve and the actuator are exactly in line – the valve has be rotated back to the same position it was in before the central knob was pulled out. If this proves to be troublesome, remove actuator by un-screwing central set screw in the middle of the actuator knob, switch on the panel, set temperature high to force the control system to rotate actuator to fully open position, rotate valve to fully open position, install actuator and tighten screw (NOTE – ensure that the back of the actuator locks into the locating dowel protruding from the valve body) and then tighten the central screw.





It should then be possible to push back in the central knob and so covering the orange sleeve. Once done, return the control temperature back to the desired value.

12.3 SETTING UP THE CONTROLLER AND START UP:

Note: It is essential that the exchanger is not subjected to thermal or mechanical shock as this could lead to premature gasket failure.

12.4 OPERATION IN AUTOMATIC MODE:

Once the pipe work and electrical connections have been made, the system should be filled and vented then all miniature circuit breakers (MCB's) located in the panel should be set to “on”. The following procedure should then be followed to start the unit:

1. The control panel should be switched on at the main isolator. The “controls healthy” lamp on the control panel will be illuminated to indicate that the panel is live with the control voltage available.
2. Each pump is fitted with a “Hand/Off/Auto selector switch. If “Hand” is selected the relevant pump will run. Similarly if “Off” is selected, the relevant pump will not run. If “Auto” is selected then the pump will run under the control of the BMS interface.
3. The temperature controller is factory set at 10% proportional span and 5 sec integral time (auto reset). These settings should give reasonable results with most systems but, depending on the thermal response of the system, some adjustment may be needed. Any such adjustment should only be carried out by competent persons. Full controller instructions are given in the separate Programming Guide available from www.lochinvar.ltd.uk..
4. Adjustment of the temperature set point can be done as follows:
 - From the normal run mode, press .
 - The lower display will then show “SP” and the upper display will show the actual set point.
 - Press  or  to change the set point to the required value.
 - Finally, press  to return to normal run mode.

ROUTINE MAINTENANCE:

Shut down: Switch panel "OFF" at main isolator.
Allow unit to cool, close isolation valves, and drain heat exchanger.

Tools: Ratchet spanners and ring or open-ended spanners, plus light machine oil. M24 (36mm across flats)

Procedure:

- Ensure the control panel is isolated and all isolation valves on the pipe work are closed.
- Allow unit to cool, and drain exchanger.
- Release all pressure from inside of exchanger.
- Lightly oil the tie bolt threads down either side of the exchanger.
- Undo the clamping bolts uniformly - keep the frame plates as parallel as possible during this operation.
- Push / pull back the mobile frame plate away from plates pack & secure if necessary.
- Separate heat transfer plates carefully, avoiding damage to gaskets.

Use gloves to handle the plates - the edges can be sharp.

12.5 CLEANING OF THE PLATES:

Safety: Wear gloves & eye goggles when using cleaning detergents.

Brushing: Use nylon or other types of "soft" scrubbing brushes with detergent. **Never** use a metal brush, steel wool, or sand/glass paper.

Detergents: Consult a cleaning specialist for a suitable choice of detergent. Ensure that all detergents used are compatible with the plate and gasket material before use.

Plate material: 316 stainless steel
Gasket material: Nitrile rubber, or EPDM

13.0 RE-ASSEMBLY OF THE HEAT EXCHANGER:



Pre-assembled plate packs are available from Lochinvar Limited, if fitting a pre-assembled plate pack then just go straight to section 14 with regards to Dimension A – referring to the table on page 19.

- Refer to the separately supplied Plate Sequence Sheet to determine the order of the plates, & the type required.
- Fit the start plate (see illustration on next page), ensuring the plate pattern is pointing in the correct direction as indicated on the plate sequence sheet.
- Fit plates in the correct order according to the Plate Sequence Sheet (supplied with the unit).
- Ensure all gaskets face towards the fixed / head frame plate (connection end).
- Alternate between left & right handed plates - if the plate edges form a regular honeycomb pattern, then the left / right hand sequence is correct (see illustration below for herringbone pattern example)

ASSEMBLY DIAGRAMS:

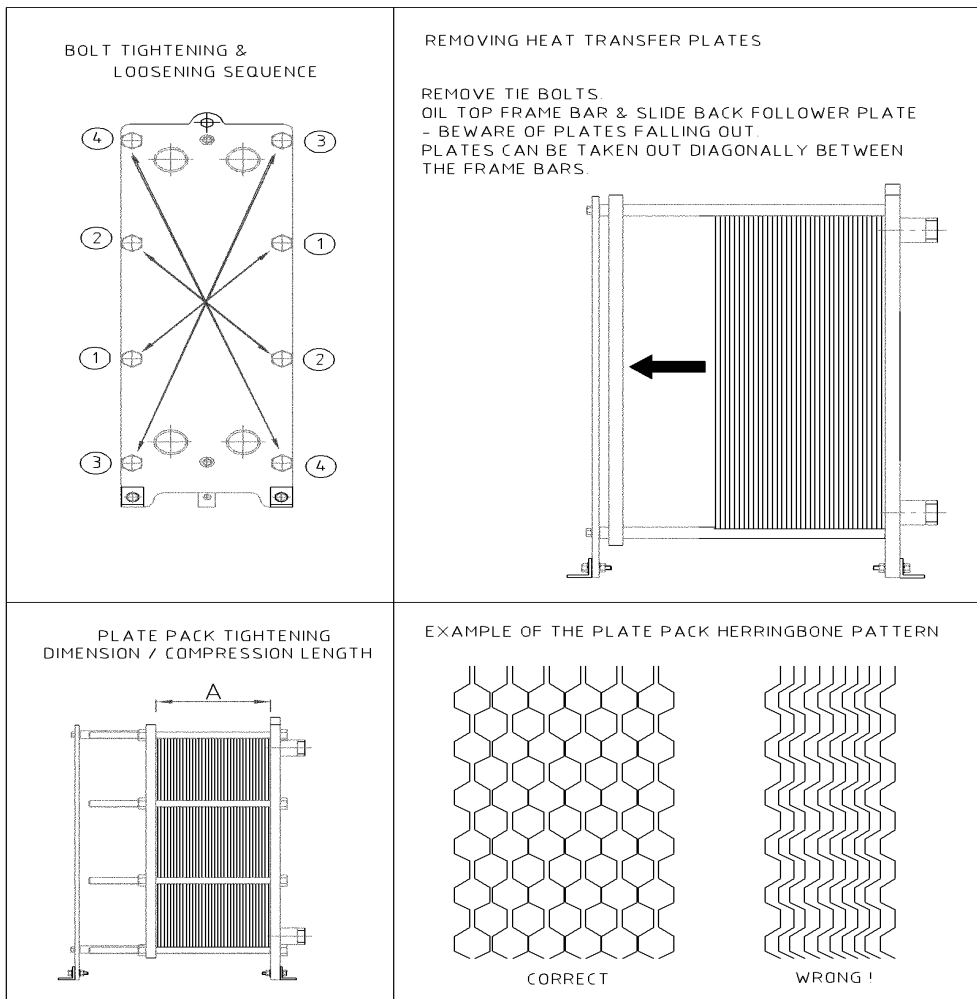

14.0 TIGHTENING OF THE PLATE PACK:

- **Procedure:**
- Lightly oil Tie bolt threads.
- Evenly tighten all bolts. We recommend the use of ratchet / friction spanners.
- Ensure clamping is as uniform as possible, thus keeping the frames plates parallel throughout the operation. Avoid skewing the frame plates by more than 10mm
- Tightening is complete when the distance between the inside faces of the two frame plates (Dimension "A" shown above) is within the compression length maximum and minimum dimensions as shown in Table 1 on page 19.
- Finally check that all bolts are in tension, and clean any spilled oil off the frame plates.
- On completion, the unit can be pressure tested at no more than 6 bar g.

LOK-8 MODEL (KW)	NO. OF PLATES	DIM A MAXIMUM (MM)	DIM A MINIMUM (MM)
50	8	24	21
100	14	39	37
150	22	62	58
200	30	84	80

250	34	95	90
300	38	106	101
350	44	123	117
400	47	132	125
LOK-14 MODEL (KW)	NO. OF PLATES	DIM A MAXIMUM (MM)	DIM A MINIMUM (MM)
450	25	74	70
500	28	83	78
550	31	91	87

TABLE 1: DIMENSION "A"



The assembly of the pack is set by a compression dimension as opposed to a torque setting. The pack will seal at the maximum dimension and should never be tightened more than the minimum dimension. Refer to 14.0 for further detail on assembly of the plate pack.

EXAMPLES OF GASKET AND PLATE TYPES:

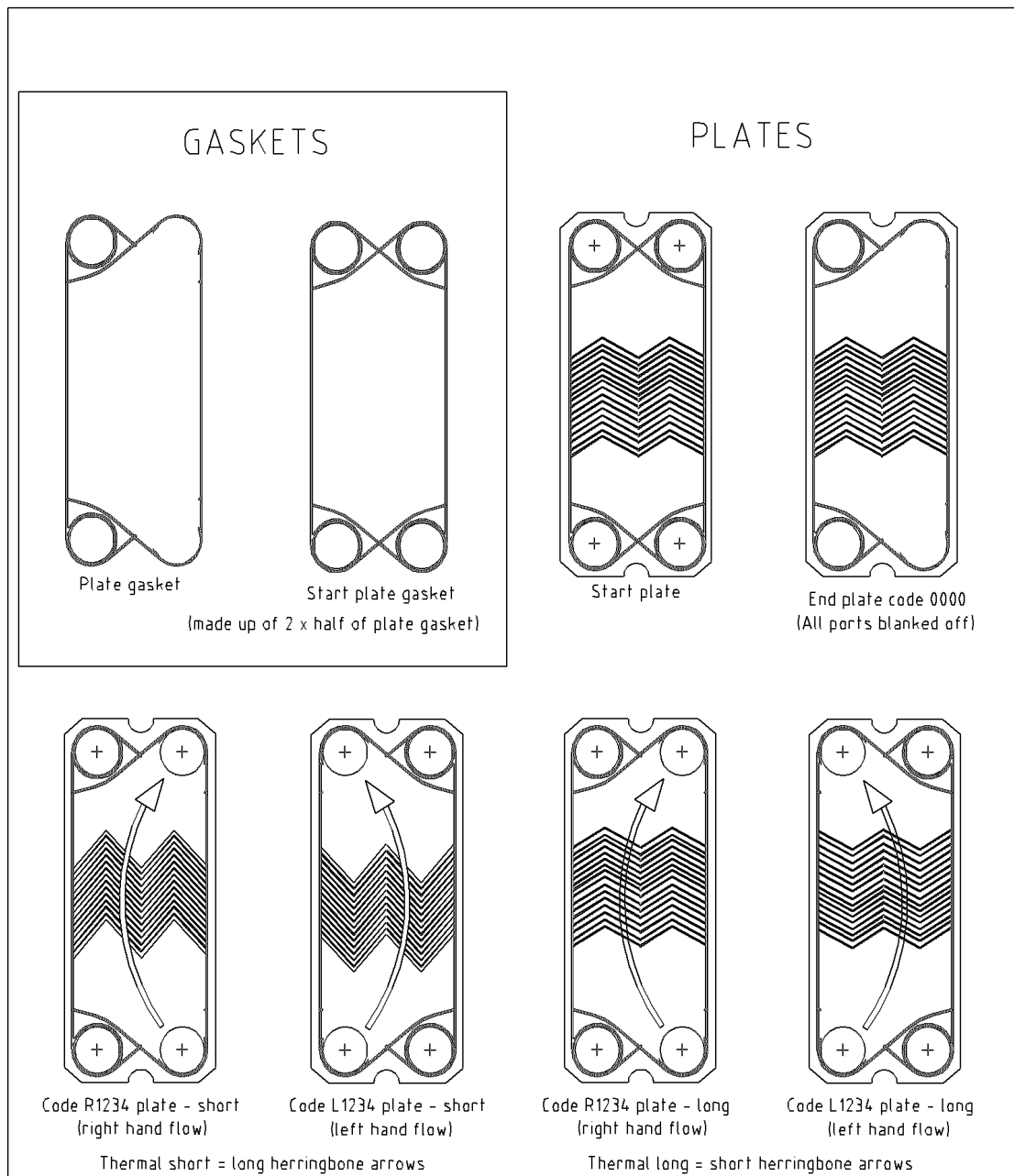

15.0 FAULT FINDING:

15.1 HEAT EXCHANGER PLATE PACK ASSEMBLY:

Problem/fault	Remedy/Corrective Action
Nuts tight to turn	Insufficient oil on threads, lubricate with suitable release oil
Plates out of alignment	Remove plates and degrease, then dry them thoroughly. Inspect plate hanging system for damage

15.2 EXCESSIVE PRESSURE DROPS:

Problem/fault	Remedy/Corrective Action
Liquid flow higher than design	Check and adjust flow
Plate channels blocked	Back flush, clean in position or dismantle and clean
Inaccurate measurement	Check pressure gauge for accuracy. Ensure that measurement does not include any bends, valves or pipework losses.
Liquid temperature below design	Viscous media generate higher resistance to flow at lower temperatures
Media used not as design	The addition of Glycol or other additives can increase the pressure drop

15.3 LEAKAGE:

Problem/fault	Remedy/Corrective Action
Leakage near connection	First heat transfer plate possibly damaged, dismantle the heat exchanger plate pack and inspect. If threaded connections are rotated when in situ, damaged can occur to the backing O rings (connections must be "held against" when installing pipework).
Flange gaskets leaking	Check gaskets and replace if required. Ensure that flanged joints are drawn up "square"
Crack in weld at joint	Use a Dye Pen to indicate the crack, the crack can be repaired by welding. REMOVE ALL PLATES BEFORE WELDING
Cross contamination of water	Check all plates for cracks or holes. Replace damaged plates and gaskets
Leakage from the plate pack	Check the tightening dimension (this should be found on the plate sequence sheet). Check the condition of the gaskets and replace if required. Check that all gaskets are seated correctly, re-seat or replace if required.

For nearly all leakage problems, it will be necessary to dismantle the plate pack before any attempts to rectify the fault can be made. Mark the area(s) from where the leaks are occurring before taking apart the exchanger to assist in fault finding once plates are taken out of exchanger.

15.4 DECREASE IN THE PERFORMANCE:

Problem/fault	Possible causes
Decrease in performance of hot water	Plate surfaces require cleaning or de-scaling. Pumps or associated controls have failed. Liquid flow not as design specification. Associated boiler undersized. Primary temperature lower than design value. Sensor faulty, check that they are secure onto pipework. Plate pack assembled incorrectly. Plate flow reverse, check pipework is correct. Check direction of pumps. Air lock has developed within the plate pack.

15.5 NO SECONDARY FLOW:

Problem/fault	Possible causes
Electrical fault	Check electrical supply to panel and associated MCBs
Pump tripped (panel fault lamp illuminated)	Reset relevant overload within the control panel via the blue reset button. <ul style="list-style-type: none"> • F112 is for primary pump 1 • F132 is for primary pump 2 (only if fitted) • F152 is for secondary pump 1 (only if fitted) • F172 is for secondary pump 2 (only if fitted)
High Limit shut down (panel fault illuminated)	The system will need to be reset after high limit shut down. Wait for a few minutes to allow the temperature to cool slightly and then press the manual re-set button.
Air lock in system	Vent the accumulated air from the system.
Incorrect operating mode	Check operation of temperature control

15.6 SECONDARY WATER TEMPERATURE INCORRECT, OR UNIT CUTS OUT ON OVER HEAT

Problem/fault	Remedy/Corrective Action
Wrong set point on controller.	Adjust Controller – see relevant section in manual
Air Lock in pipe work	Vent System of accumulated air
Primary water temperature too high or too low.	Ensure that boiler or source of primary temperature water is functioning correctly & rectify as required.
Primary water flow too high / too low, or secondary flow not correct	Ensure that primary and/or secondary water pump(s)/source is/are performing correctly & rectify as required.
Fault in temperature sensor	Check sensor and cables. Isolate panel, then disconnect the temperature sensor wires (not the Overheat Thermostat) out of the panel and measure the resistance. The resistance should be around 110 ohms (depending on temperature. If a reading of “infinite” is shown then there is an open circuit, and the most likely cause is that the wires leading to and from the sensor are broken. If the reading is zero, then there is a short circuit. Check/replace the wires/sensor.
Actuator fault – the valve does not modulate, or move during operation.	Possible actuator failure – remove from valve (see actuator replacement section). Alter set point to low temperature and check to see if actuator drive turns to fully closed position, and then alter set point to a high temperature and check to see if drive rotates a full 90 degrees from fully closed position. If no, or in-sufficient travel of the drive is observed, then actuator requires replacement.
Control valve seized or binding	Check for binding/seizure – remove actuator (see actuator removal section) and then try to rotate valve stem – you can use grips on the end of the stem as an aid but make sure that the stem is protected from damage from the grips. The valve should rotate freely throughout the range of travel. Sediment build up can block the action of the valve and this rotating action can sometimes be enough to free the component. If binding persists then isolate the unit, shut down, and drain primary circuit. The inner parts of the valve can be removed without taking the complete valve off the pipework:
Primary circuit pressure feeding PHE too high	Check primary pipework and expansion vessel charge. Set correct expansion vessel charge and reduce pressure in primary pipework

15.7 CONTROL VALVE MAINTENANCE - CAST IRON VALVE TYPE:

- Loosen the 4 bolts on the side of the valve body and pull body back to the side panel. This may require a lever, but try to avoid damage to the sealing face. Inspect, clean and lubricate or replace with new components. If it looks as though the paddle is binding against the valve body then the paddle then any “proud” or high points can be shaved down by the use of wet and dry or emery paper.

15.8 CONTROL VALVE MAINTENANCE - BRASS VALVE TYPE:

- Rotate the silver disk until the lugs on the disk are no longer under the brass noggins and then pull out the stem and valve paddle – there is a sealing O-ring which needs to be protected from damage. If the paddle is tight to remove then replace the central bolt into the stem and use the bolt to aid in pulling out the paddle part of the valve. If it looks as though the paddle is binding against the valve body then the paddle then any “proud”/high points can be shaved down by the use of wet and dry or emery paper.
- A possible remedy without taking out valve inners may be to spray a suitable release oil onto valve shaft bearing (see section on control valve in Section 9.2) and then locate the stem a few times to work in the lubricant.

16.0 PRIMARY OR SECONDARY PUMP FAILS TO OPERATE:

Problem/fault	Remedy/Corrective Action
Circuit breaker tripped or set to “off”.	Check circuit breakers inside the panel.
Thermal overload activated.	If the unit is new then check the direction of the pump rotation and check to see if the pipe work has been connected correctly. The over load setting should be checked and adjusted as necessary – contact an electrician to undertake this work. NOTE: The wiring diagram illustrates the location of the overload and the factory setting. There is a scaled dial on the overload which can be rotated to Increase/decrease the overload current. NOTE: If the overload setting is too high, the protection level for the pump is reduced.
Pump motor burnt out or faulty.	Replace the faulty or burnt out pump motor if required.

17.0 ACTUATOR REPLACEMENT:

1. Switch off the heat exchanger at the control panel.
2. Undo the central bolt holding the actuator to the valve stem and pull off the complete actuator assembly.
3. Remove the small cross head screw holding the actuator cover and remove the cover and wiring plug
4. Note position of the small dip switches on the printed circuit board.
5. Spray a suitable release oil into the valve stem bearing to lubricate the valve and rotate a few times from left to right.
6. Remove the cover on the new actuator and set the dip switches as noted in step 4.
7. Fit the wiring plug and refit the actuator cover and retaining screw.
8. Rotate the control valve stem fully clockwise until it stops.
9. Switch on the control panel
10. Adjust the temperature setpoint to its maximum value to force the control system to rotate actuator to the fully open position.
11. Install the actuator and tighten the retaining bolt

NOTE: Ensure that the back of the actuator locks into the locating dowel protruding from the valve body before tightening the central retaining bolt.

NOTE: Do not over tighten and ensure that the pointer is to the right (valve fully open), and that the actuator knob is fully pushed in.

12. Adjust the temperature setpoint to its minimum value; the actuator should move until it stops at its fully closed position.
13. Adjust the temperature setpoint to its maximum value to force the control system to rotate actuator to the fully open position.
14. Set the temperature setpoint to the desired value.

18.0 PLANNED MAINTENANCE:

- **Time interval:** Once a year as a minimum.
- **Performance:** Check temperatures and flows against commissioning data.
- **Plate pack:** Check the tightening dimension and look for any signs of leakage from the heat exchanger.
- **Nozzles:** Check general condition, and for any signs of leakage.
- **Frame:** wipe clean all painted parts, and check surfaces for signs of damage - "touch up" if necessary.
- **Bolts & bars:** Check for rust, and clean. Lightly coat threaded parts with molybdenum grease, or a corrosion inhibitor (ensure that no grease, etc. falls onto the plate gaskets).
- **Electrical:** Check the security of all electrical connections and inspect the wiring for damage.
- **Actuator/valve:** Spray a suitable release oil into valve spindle where it enters the valve..

19.0 WARRANTY:

Full warranty terms and conditions are available at www.lochinvar.ltd.uk



8 Lombard Way, The MXL Centre, Banbury, Oxon, OX16 4TJ
Tel: +44(0) 1295 269 981, Fax: +44(0) 1295 271 640, Email: info@lochinvar.ltd.uk
www.lochinvar.ltd.uk