

# LST Direct Storage Vessel

Installation, Commissioning,  
User & Maintenance Instructions

Models:

LST 330 G E

LST 440 G E

LST 550 G E

LST 660 G E

LV312749 | March 2025





## **IMPORTANT INFORMATION**

These instructions must be read and understood before installing, commissioning, operating or maintaining the equipment.

---

**Read this manual carefully**

---

**Warning**

Read this manual carefully before starting with the installation of the storage vessel. Failure to read the manual and to follow the printed instructions may lead to personal injury and damage to the storage vessel.

---

**Copyright © 2022**

All rights reserved.

Nothing from this publication may be copied, reproduced and/or published by means of printing, photocopying or by whatsoever means, without the prior written approval of the supplier.

The supplier reserves the right to modify specifications stated in this manual.

**Trademarks**

Any brand names mentioned in this manual are registered trademarks of their respective owners.

**Liability**

The supplier accepts no liability for claims from third parties arising from unauthorised use, use other than that stated in this manual, and use other than in accordance with the General Conditions registered at the Chamber of Commerce.

Refer further to the General Conditions. These are available on request, free of charge.

Although considerable care has been taken to ensure a correct and suitably comprehensive description of all relevant components, the manual may nonetheless contain errors and inaccuracies. Should you detect any errors or inaccuracies in the manual, we would be grateful if you would inform us. This helps us to further improve our documentation.

**More information**

If you have any comments or queries concerning specific aspects related to the storage vessel, then please do not hesitate to contact the supplier.

In the event of problems with your water supply connections, please contact the supplier and/or installation engineer of your installation.

**Regulations**

If the Lochinvar LST is to be used in an unvented system installation, the system should follow the guidance given in BS6700, BS8558 and must comply with the Building Regulations 1992: Part G3, in England and Wales, P5 in Northern Ireland and P3 in Scotland and the Water Supply (Water Fittings) Regulations 1999, The Water Supply (Water Quality) Regulations (Northern Ireland) 2017 and the Public Water Supplies (Scotland) Amendment Regulations 2017.

A kit of parts is available from Lochinvar.



# Table of contents

<b>1</b>	<b>Technical specifications</b> .....	<b>7</b>
1.1	Floor load .....	7
1.2	Working clearance .....	7
1.3	Packaging .....	7
1.4	Disposal .....	7
1.5	General specifications .....	7
1.6	Dimensions .....	8
<b>2</b>	<b>Installation</b> .....	<b>9</b>
2.1	Installation diagram .....	9
2.2	Water connections .....	10
<b>3</b>	<b>Filling and Draining</b> .....	<b>11</b>
3.1	Filling .....	11
3.2	Draining .....	12
<b>4</b>	<b>Maintenance</b> .....	<b>13</b>
4.1	Preparation for maintenance .....	13
4.2	Water-side maintenance .....	13
<b>5</b>	<b>Warranty</b> .....	<b>15</b>



# 1 Technical specifications

## 1.1 Floor load

Allow for the storage vessels weight and the maximum floor load; refer to the table (1.5 "General specifications").

## 1.2 Working clearance

For access to the storage vessel, it is recommended that the following clearances are observed:

- around the anode connection: 100 cm.
- around the vessel: 50 cm.
- top of the vessel: 50 cm

### Note

When installing the storage vessel, be aware that any leakage from the tank and/or connections can cause damage to the immediate environment or floors below the level of the boiler room. If this is the case, the storage vessel should be installed above a waste water drain or in a suitable metal leak tray.

The leak tray must have an appropriate waste water drain and must be at least 5 cm deep with a length and width at least 5 cm greater than the diameter of the storage vessel.

## 1.3 Packaging

The packaging prevents damage to the appliance during transport. The packaging material chosen is environmentally friendly, recyclable and relatively easy to dispose of in an environmentally aware way.



## 1.4 Disposal

Old end-of-life appliances contain materials that need to be recycled. When disposing of old devices that have reached the end of their service life, you should take account of local legislation relating to waste disposal.

You must therefore never dispose of your old appliance together with regular waste, but should and it into a municipal waste collection depot for electrical and electronic equipment. Ask your dealer/installation engineer for advice if necessary. The old appliance must be stored out of reach of children.



## 1.5 General specifications

Description	Unit	LST 330	LST 440	LST 550	LST 660
Storage Capacity	liters	1550	1880	2500	2820
Empty Weight	kg	325	350	485	520
Max. Floor Load	kg	1875	2230	2985	3340
Energy Efficiency Class (Energy Label)	-	-	-	-	-
Heat Loss	W	154	171	232	243
Max. Working Pressure Tank	KPa (bar)	700 (7)	700 (7)	700 (7)	700 (7)
Max. Water Temperature Tank	°C	95	95	95	95
Anodes	-	3	3	3	3

## 1.6 Dimensions

		Unit	LST 330	LST 440	LST 550	LST 660
A	Total height	mm	1985	2175	2045	2070
D	Diameter (without insulation)	mm	1100	1100	1400	1400
	Diameter (with insulation)	mm	1300	1300	1600	1600
F	Height connection	mm	1190	1340	1220	1270
M	Height cold water inlet	mm	135	135	185	185
N	Height warm water outlet	mm	1985	2175	2045	2170
P	Height inspection opening	mm	450	450	530	530
R	Height circulation	mm	710	745	790	790
S	Height immersion well/temp. sensor	mm	950	1045	980	1045
T	Height T&P connection	mm	1515	1705	1495	1625
W	Height connection	mm	385	385	465	465
X	Height connection	mm	485	485	565	565
Y	Height connection	mm	585	585	665	665
1	Connection cold water inlet	-	R 2"	R 2"	R 2"	R 2"
2	Connection warm water outlet	-	R 2"	R 2"	R 2"	R 2"
5	Connection circulation	-	Rp 1 1/4"	Rp 1 1/4"	Rp 1 1/4"	Rp 1 1/4"
6	Diameter inspection opening	mm	110	110	110	110
7	Connection T&P	-	Rp 2"	Rp 2"	Rp 2"	Rp 2"
8	Connection immersion well/temp. sensor	-	Rp 3/4"	Rp 3/4"	Rp 3/4"	Rp 3/4"
10	Connection anode	-	Rp 3/4"	Rp 3/4"	Rp 3/4"	Rp 3/4"
12	Connection	-	Rp 2"	Rp 2"	Rp 2"	Rp 2"
13	Connection	-	Rp 2"	Rp 2"	Rp 2"	Rp 2"
14	Connection	-	Rp 1/4"	Rp 1/4"	Rp 1/4"	Rp 1/4"
15	Connection	-	Rp 3/4"	Rp 3/4"	Rp 3/4"	Rp 3/4"

Dimensioned Sketch

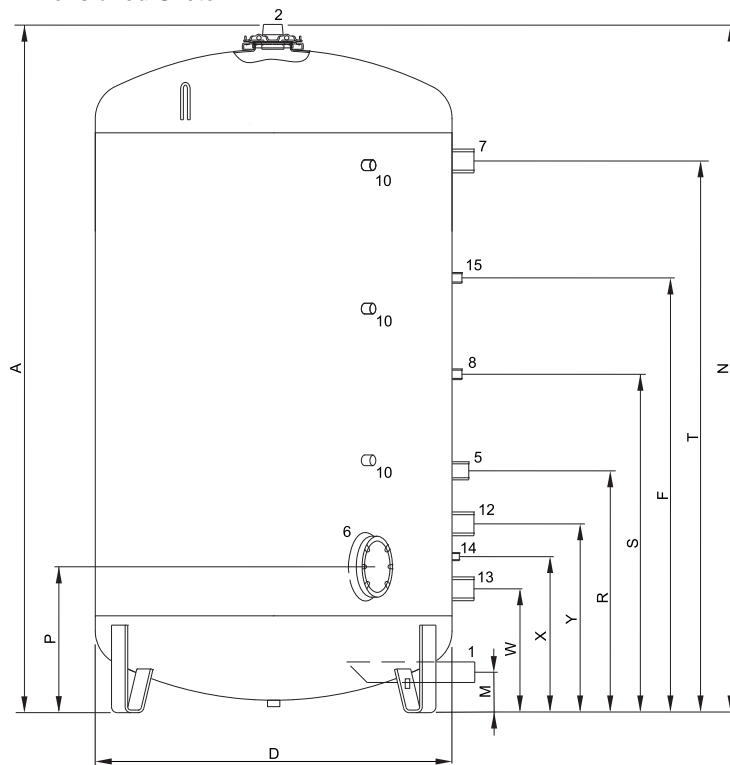

IMD-1301 R0



# 2 Installation

---

## Important

Three anodes are delivered with the storage vessel. Mount the anodes with a liquid sealant in the right connections (8) before installation. When anodes are not mounted during operation, all warranty conditions are void.

---

## Note

These products can be installed as vented and unvented. This manual only discusses unvented installations. For information about vented installations please contact your supplier.

---

### 2.1 Installation diagram

These figures below shows the installation diagrams. These diagrams are referred to in the sections describing the actual connection procedure.

#### Installation Diagram

#### Legend

1. pressure relief valve (mandatory)
3. T&P-valve (mandatory)
4. stop valve (recommended)
5. non-return valve (mandatory)
6. circulation pump (optional)
9. drain valve
11. service stop valve
12. temperature gauge (optional)
14. draw-off points
15. expansion valve (mandatory)
16. expansion vessel (mandatory)

- A. cold water supply  
B. hot water supply  
C. circulation pipe

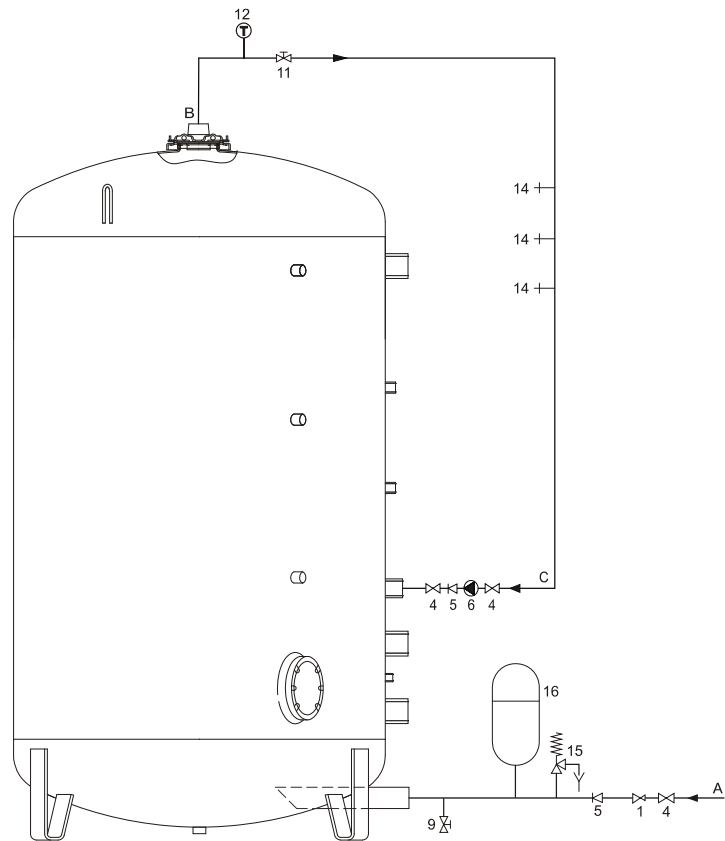

IMD-0645 R0

### 2.2 Water connections

---

## Warning

The installation should be carried out by a competent person, in compliance with general and locally applicable regulations.

---

### 2.2.1 Cold water side

See (A) in the installation diagram ([2.1 "Installation diagram"](#)).

1. Fit an approved stop valve (4) on the cold water side as required by the applicable regulations.
2. The maximum working pressure of the storage vessel is 8 bar. Because the pressure in the water pipe at times can exceed 8 bar, you must fit an approved pressure-reducing valve (1).
3. Fit a non-return valve (5) and an expansion vessel (16).
4. Fit an expansion valve (15) and connect the overflow side to an open waste water pipe.

### 2.2.2 Hot Water side

See (B) in the installation diagram ([2.1 "Installation diagram"](#)).

---

#### Note

Insulating long hot water pipes prevents unnecessary energy loss.

---

1. Optional: fit a temperature gauge (12) so you can check the temperature of the tap water.
2. Fit the T&P valve (3).
3. Fit a stop valve (11) in the hot water outlet pipe for servicing.

### 2.2.3 Circulation pipe

See (C) in the installation diagram ([2.1 "Installation diagram"](#)).

If an immediate flow of hot water is required at draw-off points, a circulation pump can be installed. This improves comfort, and reduces water wastage.

1. Fit a circulation pump (6) of the correct capacity for the length and resistance of the circulation system.
2. Fit a non-return valve (5) after the circulation pump to guarantee the direction of circulation.
3. Fit two stop valves for servicing (4).
4. Connect the circulation pipe according to the installation diagram ([2.1 "Installation diagram"](#)).

# 3 Filling and draining

---

## Important

Three anodes are delivered with the storage vessel. Mount the anodes with a liquid sealant in the right connections (8) before installation. When anodes are not mounted during operation, all warranty conditions are void.

---

## Note

These products can be installed as vented and unvented. This manual only discusses unvented installations. For information about vented installations please contact your supplier.

---

### Installation Diagram

#### Legend

1. pressure relief valve (mandatory)
3. T&P-valve (mandatory)
4. stop valve (recommended)
5. non-return valve (mandatory)
6. circulation pump (optional)
9. drain valve
11. service stop valve
12. temperature gauge (optional)
14. draw-off points
15. expansion valve (mandatory)
16. expansion vessel (mandatory)

- A. cold water supply  
B. hot water supply  
C. circulation pipe  
F. inlet heat exchanger  
G. outlet heat exchanger

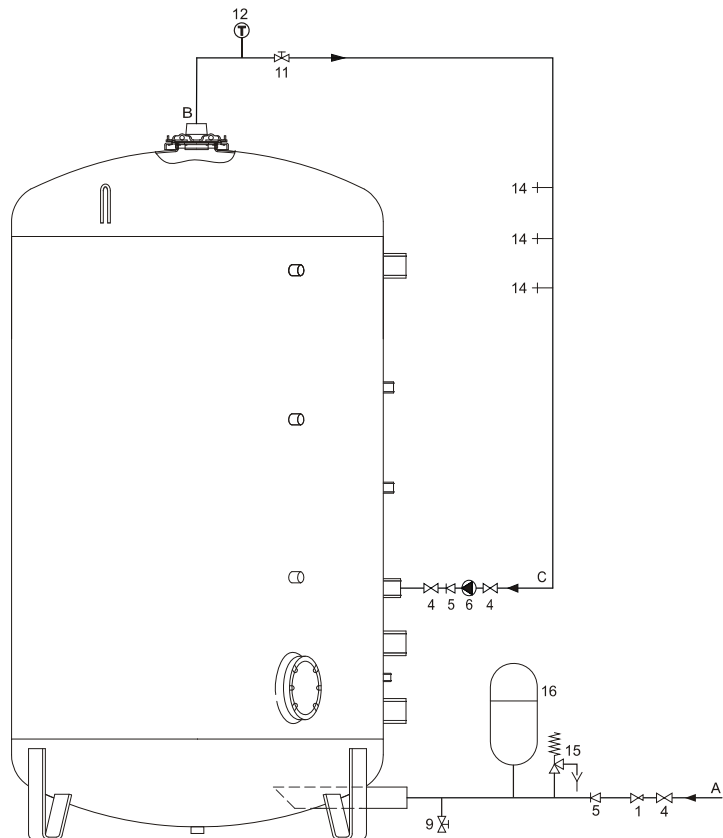

IMD-0645 R0

### 3.1 Filling

To fill the water heater, proceed as follows:

1. Open the stop valve (11) in the hot water pipe and, if present, the stop valves (4) for the circulation pump (6).
2. Close the drain valve (9).
3. Open the nearest hot water draw-off point (14).
4. Open the stop valve (4) on the cold water side (A) so that cold water flows into the water heater.
5. Completely fill the water heater. When a full water jet flows from the nearest draw-off point, the water heater is full.

6. Bleed the entire installation of air, for example by opening all draw-off points.
7. The water heater is now under water supply pressure. There should now be no water coming out of the inlet combination expansion valve or (if used) out of the T&P valve (3). If there is, the cause might be:
  - The water supply pressure is greater than the specified value (1.6 "General specifications"). Rectify this by fitting a pressure reducing valve (1).
  - The expansion valve in the protected cold supply set-up is defective or incorrectly fitted.

### **3.2 Draining**

1. Close the stop valve (4) between the cold water head tank and the cold water inlet (A).
2. Open the drain valve (9).
3. Bleed the water heater (or installation) so that it drains completely.

# 4 Maintenance

---

**Warning**

Maintenance may only be carried out by a competent person.

---

At each service, the storage vessel undergoes maintenance on water side. The maintenance must be carried out in the following order.

1. Preparation for maintenance
  2. Water-side maintenance
  3. Finalising maintenance
- 

**Note**

Before ordering spare parts, it is important to write down the installation type, storage vessel model and the full serial number of the storage vessel. These details can be found on the rating plate. Only by ordering with this information can you be sure receiving the correct spare parts.

---

## 4.1 Preparation for maintenance

The preparation for maintenance consists of testing and checking if all components are still working properly by completing the following steps:

1. Test the operation of the overflow valve of the protected cold supply setup. The water should discharge out.
2. Check the drainage pipes from the discharge points of all valves and remove any scale deposits that may be present.
3. Drain the storage vessel.

## 4.2 Water-side maintenance

Water-side maintenance consists of descaling and cleaning the tank and checking the anodes.

### 4.2.1 Descaling and cleaning the tank

Scale and lime build-up prevent effective conduction of the heat to the water. Periodic cleaning and descaling prevents build-up of these deposits. This increases the service life of the storage vessel, and also improves the heating process.

Take the rate of scale formation into account when deciding on the service interval. Scale formation depends on the local water composition, the water consumption and the water temperature setting. A water temperature setting of maximum 60°C is recommended for the prevention of excessive scale build-up.

To guarantee a good, watertight seal around the cleaning opening, replace the gasket, washers, bolts and, if necessary, the lid with new parts before reassembly. Spare parts are obtainable from the supplier/manufacturer.

To simplify descaling and cleaning of the tank, the storage vessel is equipped with a cleaning opening.

Work order:

1. Undo bolts from the cover.
2. Remove cover and the gasket.
3. Inspect the tank and remove the loose scale deposits and contamination.
4. If the scale cannot be removed by hand, descale the water heater with a descaling agent. Contact the supplier/manufacturer for advice on what descaling agent to use.
5. Close the cleaning opening. To avoid damage to the tank, tighten the bolts that fasten the lid, with a torque no greater than 50 Nm. Use suitable tools for this.

#### **4.2.2 Checking anodes**

Anodes ensure the protection of the tank by sacrificing themselves. Insufficient anode material may lead to poor protection and, hence, leakage of the tank.

1. Loosen the anodes one by one.
2. Check the diameter of each anode in different places. The diameter must be at least 60% of the original 1" diameter.
3. If the diameter is less than the minimum, the anode must be replaced. Please contact the supplier/manufacturer to order new anodes.
4. Mount the (new) anodes.

# 5 Warranty

Contact Lochinvar Ltd. or got to [www.lochinvar.ltd.uk](http://www.lochinvar.ltd.uk) for the current warranty terms and conditions.



8 Lombard Way, The MXL Centre, Banbury, Oxon, OX16 4TJ  
Tel: +44(0) 1295 269 981, Fax:+44(0) 1295 271 640, Email: info@lochinvar.ltd.uk  
www.lochinvar.ltd.uk

*Lochinvar Ltd reserves the right to change specifications without prior notice*